



Cost-effective solution
for simple identification tasks

RFID-SYSTEM LF (125 KHZ) BIS L



Our low-frequency RFID systems BIS L are suitable for applications that involve only the identification and require less data processing. For example, often only a (read-only) code is required for tracing. The 125-kHz systems function reliably up to ranges of 100 mm and are relatively neutral with respect to materials such as water, textiles, wood and aluminum.

Features

- Data carrier memory limited to 192 bytes
- For sending smaller quantities of data
- Wide range of data carriers
- Unique ID with 5 bytes, read-only
- Read-only data carriers available (protection against manipulation)



	BIS0035 BIS L-100-05/L-R0	
Product Group	LF (125 kHz)	
Dimension	Ø 20 x 1.6 mm	
UID serial number, read-only	5 Byte	
User data, read/write	—	
Memory type	EEPROM	
Antenna type	round	
Installation	metal-free (clear zone) on metal flush in metal	
Storage temperature	-40...95 °C	
Storage temperature temporary	—	
Ambient temperature	-25...85 °C	
Housing material	Epoxy resin-glass fiber, GF	
Protection degree	IP67	
Approval/Conformity	CE	
Productview	Page 447	

Suitable read/write head with max. read/write working distance

Installation	flush in metal	on metal	metal-free (clear zone)	
BIS L-40x-xxx-001	5-12	0-15	0-30	
BIS L-40x-xxx-002			0-23	
BIS L-40x-xxx-003				
BIS L-40x-xxx-004			0-23	
BIS VL-300	10-20	10-25	0-40	
BIS VL-301	20-50	20-50	0-70	
BIS VL-302	8-15	8-15	0-25	
BIS VL-304	8-15	8-15	0-25	
BIS VL-306				
Dimensions in mm				
* Installation on request				



BIS0038 BIS L-101-05/L-R0	BIS003C BIS L-102-05/L-R0	BIS003F BIS L-103-05/L-R0
LF (125 kHz)	LF (125 kHz)	LF (125 kHz)
Ø 30 x 1.6 mm	Ø 50 x 1.6 mm	Ø 12.4 x 2 mm
5 Byte	5 Byte	5 Byte
—	—	—
EEPROM	EEPROM	EEPROM
round	round	round
metal-free (clear zone) on metal flush in metal	metal-free (clear zone) on metal flush in metal	metal-free (clear zone) on metal flush in metal
-40...95 °C	-40...95 °C	—
—	—	-40...130 °C 1x1000 h
-25...85 °C	-25...85 °C	-25...85 °C
Epoxy resin-glass fiber, GF	Epoxy resin-glass fiber, GF	PPS, EP
IP67	IP67	IP68
CE	CE	CE
Page 447	Page 447	Page 447

flush in metal	on metal	metal-free (clear zone)	flush in metal	on metal	metal-free (clear zone)	flush in metal	on metal	metal-free (clear zone)
0-18	0-24	0-40	0-28	0-32	0-55			0-20
		0-27						0-16
		0-27						0-11
		0-27						0-16
10-30	10-35	0-50	15-40	15-45	0-70	3-10	3-12	0-25
20-40	20-45	0-70	25-55	25-60	0-100			
10-20	10-20	0-30	10-20	10-25	0-40	3-8	4-10	0-15
10-20	10-20	0-30	10-20	10-25	0-40	3-8	4-10	0-15
								0-7



	BIS003R BIS L-200-03/L	
Product Group	LF (125 kHz)	
Dimension	Ø 20 x 1.6 mm	
UID serial number, read-only	5 Byte	
User data, read/write	—	
Memory type	PROM	
Antenna type	round	
Installation	metal-free (clear zone) on metal flush in metal	
Storage temperature	-40...95 °C	
Storage temperature temporary	—	
Ambient temperature	-40...85 °C	
Housing material	Epoxy resin-glass fiber, GF	
Protection degree	IP67	
Approval/Conformity	CE	
Productview	Page 447	

Suitable read/write head with max. read/write working distance

Installation	flush in metal	on metal	metal-free (clear zone)	
BIS L-40x-xxx-001	5-12	0-15	0-30	
BIS L-40x-xxx-002			0-23	
BIS L-40x-xxx-003				
BIS L-40x-xxx-004			0-23	
BIS VL-300	10-20	10-25	0-40	
BIS VL-301	20-50	20-50	0-70	
BIS VL-302	8-15	8-15	0-25	
BIS VL-304	8-15	8-15	0-25	
BIS VL-306				
Dimensions in mm				
* Installation on request				



BIS003T BIS L-201-03/L	BIS003U BIS L-202-03/L	BIS003W BIS L-203-03/L
LF (125 kHz)	LF (125 kHz)	LF (125 kHz)
Ø 30 x 1.6 mm	Ø 50 x 1.6 mm	Ø 12.4 x 2 mm
5 Byte	5 Byte	5 Byte
—	—	—
PROM	PROM	PROM
round	round	round
metal-free (clear zone) on metal flush in metal	metal-free (clear zone) on metal flush in metal	metal-free (clear zone) on metal flush in metal
-40...95 °C	-40...95 °C	—
—	—	-40...130 °C 1x1000 h
-40...85 °C	-40...85 °C	-25...85 °C
Epoxy resin-glass fiber, GF	Epoxy resin-glass fiber, GF	PPS, EP
IP67	IP67	IP68
CE	CE	CE
Page 447	Page 447	Page 447

flush in metal	on metal	metal-free (clear zone)	flush in metal	on metal	metal-free (clear zone)	flush in metal	on metal	metal-free (clear zone)
0-18	0-24	0-40	0-28	0-32	0-55			0-20
		0-23						0-16
								0-11
		0-27						0-16
10-30	10-35	0-50	15-40	15-45	0-70	3-10	3-12	0-25
20-40	20-45	0-70	25-55	25-60	0-100			
10-20	10-20	0-30	10-20	10-25	0-40	3-8	4-10	0-15
10-20	10-20	0-30	10-20	10-25	0-40	3-8	4-10	0-15
								0-7



	BIS0033 BIS L-100-01/L	
Product Group	LF (125 kHz)	
Dimension	Ø 20 x 1.6 mm	
UID serial number, read-only	4 Byte	
User data, read/write	192 Byte	
Memory type	EEPROM	
Antenna type	round	
Installation	metal-free (clear zone) on metal flush in metal	
Storage temperature	-40...95 °C	
Storage temperature temporary	—	
Ambient temperature	-25...85 °C	
Housing material	Epoxy resin-glass fiber, GF	
Protection degree	IP67	
Approval/Conformity	CE	
Productview	Page 447	

Suitable read/write head with max. read/write working distance

Installation	flush in metal	on metal	metal-free (clear zone)	
BIS VL-300	10-20	10-20	0-30	
BIS VL-301	15-25	15-30	0-40	
BIS VL-302	8-15	8-15	0-20	
BIS VL-304	8-15	8-15	0-20	
BIS VL-306				
Dimensions in mm				
* Installation on request				



BIS0034 BIS L-100-05/L	BIS0036 BIS L-101-01/L	BIS0037 BIS L-101-05/L
LF (125 kHz)	LF (125 kHz)	LF (125 kHz)
Ø 20 x 1.6 mm	Ø 30 x 1.6 mm	Ø 30 x 1.6 mm
4 Byte	4 Byte	4 Byte
192 Byte	192 Byte	192 Byte
EEPROM	EEPROM	EEPROM
round	round	round
metal-free (clear zone) on metal flush in metal	metal-free (clear zone) on metal flush in metal	metal-free (clear zone) on metal flush in metal
-40...95 °C	-40...95 °C	-40...95 °C
—	—	—
-25...85 °C	-25...85 °C	-25...85 °C
Epoxy resin-glass fiber, GF	Epoxy resin-glass fiber, GF	Epoxy resin-glass fiber, GF
IP67	IP67	IP67
CE	CE	CE
Page 447	Page 447	Page 447

flush in metal	on metal	metal-free (clear zone)	flush in metal	on metal	metal-free (clear zone)	flush in metal*	on metal*	metal-free (clear zone)*
			10-30	10-30	0-40			
			15-35	15-40	0-55			
			10-20	10-20	0-25			
			10-20	10-20	0-25			
		0-12						



	BIS0039 BIS L-102-01/L	
Product Group	LF (125 kHz)	
Dimension	Ø 50 x 1.6 mm	
UID serial number, read-only	4 Byte	
User data, read/write	192 Byte	
Memory type	EEPROM	
Antenna type	round	
Installation	metal-free (clear zone) on metal flush in metal	
Storage temperature	-40...95 °C	
Storage temperature temporary	—	
Ambient temperature	-25...85 °C	
Housing material	Epoxy resin-glass fiber, GF	
Protection degree	IP67	
Approval/Conformity	CE	
Productview	Page 447	

Suitable read/write head with max. read/write working distance

Installation	flush in metal	on metal	metal-free (clear zone)	
BIS VL-300	15-40	15-40	0-55	
BIS VL-301	20-50	20-50	0-70	
BIS VL-302	10-20	10-25	0-30	
BIS VL-304	10-20	10-25	0-30	
BIS VL-306				
Dimensions in mm * Installation on request				



BIS003A BIS L-102-05/L	BIS003E BIS L-103-05/L	BIS00KR BIS L-140-05/L-M8
LF (125 kHz)	LF (125 kHz)	LF (125 kHz)
Ø 50 x 1.6 mm	Ø 12.4 x 2 mm	Ø 22 x 21 mm
4 Byte	4 Byte	4 Byte
192 Byte	192 Byte	192 Byte
EEPROM	EEPROM	PROM
round	round	round
metal-free (clear zone) on metal flush in metal	metal-free (clear zone) on metal flush in metal	metal-free (clear zone) on metal flush in metal
-40...95 °C	—	-25...95 °C
—	-40...130 °C 1x1000 h	—
-25...85 °C	-25...85 °C	-25...85 °C
Epoxy resin-glass fiber, GF	PPS, EP	Steel, PA 12, GF30
IP67	IP68	—
CE	CE	CE
Page 447	Page 447	Page 447

flush in metal	on metal	metal-free (clear zone)	flush in metal	on metal	metal-free (clear zone)	flush in metal*	on metal*	metal-free (clear zone)*
15-40	15-45	0-70						
25-55	25-60	0-100						
10-20	10-25	0-40						
10-20	10-25	0-40						
					0-7			



	BIS003N BIS L-150-05/A
Product Group	LF (125 kHz)
Dimension	Ø 3.15 x 13.3 mm
UID serial number, read-only	4 Byte
User data, read/write	192 Byte
Memory type	EEPROM
Antenna type	Rod
Installation	metal-free (clear zone) on metal flush in metal
Storage temperature	—
Storage temperature temporary	-40...90 °C 1x1000 h
Ambient temperature	-40...85 °C
Housing material	Glass, transparent
Protection degree	IP68
Approval/Conformity	CE
Productview	Page 447

Suitable read/write head with max. read/write working distance

Installation	flush in metal	on metal	metal-free (clear zone)
BIS VL-301			0-32
BIS VL-350	0-24	0-24	0-17
Dimensions in mm			

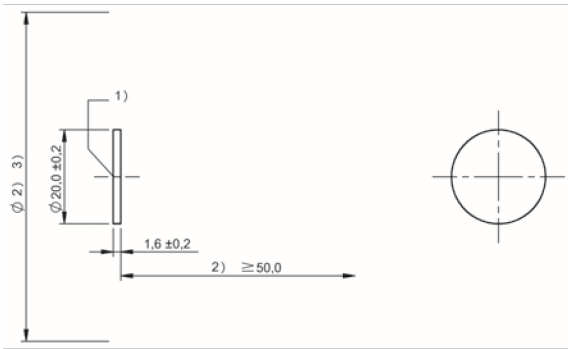

1) Sensing surface, 2) Clear zone, 3) see corresponding R/W head

BISO035, BISO03R, BISO033, BISO034

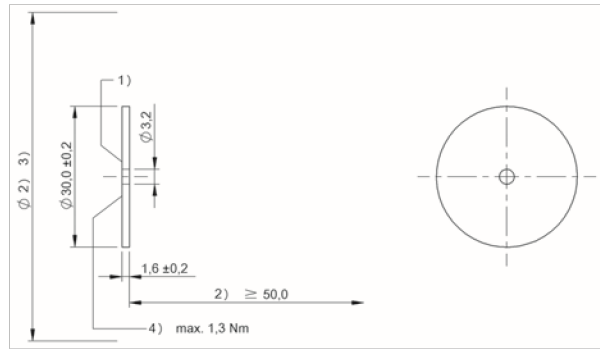

1) Sensing surface, 2) Clear zone, 3) see corresponding R/W head, 4) Tightening torque

BISO038, BISO03T, BISO036, BISO037

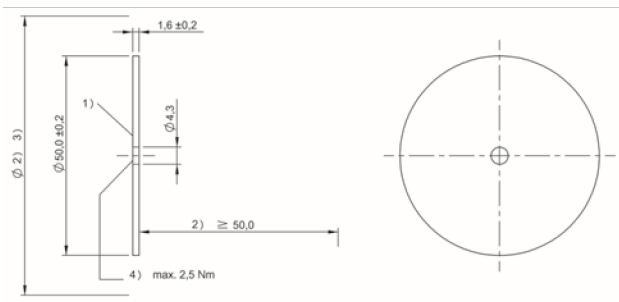

1) Sensing surface, 2) Clear zone, 3) see corresponding R/W head, 4) Tightening torque

BISO03C, BISO03U, BISO039, BISO03A

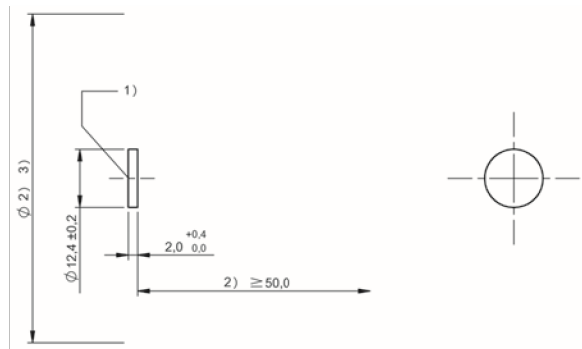

1) Sensing surface, 2) Clear zone, 3) see corresponding R/W head

BISO03F, BISO03W, BISO03E

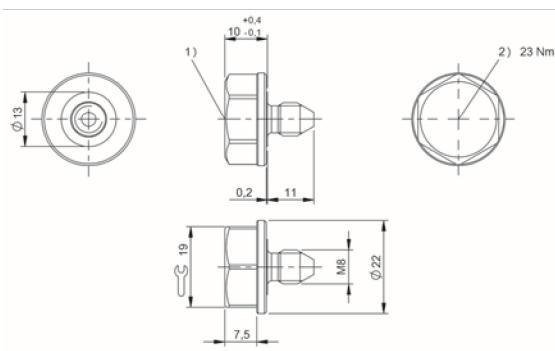

1) Sensing surface, 2) Tightening torque

BISO0KR

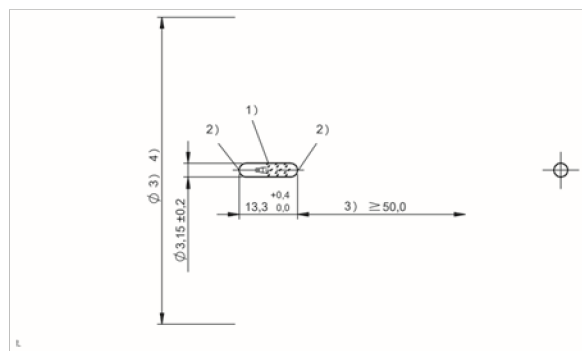

1) Sensing surface parallel, 2) Sensing surface axial, 3) Clear zone, 4) see corresponding R/W head

BISO03N



	BIS00UL BIS VL-300-001-S4
Product Group	LF (125 kHz)
Dimension	Ø 30 x 82 mm
Installation	metal-free (clear zone)
Antenna type	round
Connection	M12x1 connector, 4-pin
Housing material	PVDF, nuts PA 6.6
Interface	—
Operating voltage U _b	—
Storage temperature	-20...85 °C
Ambient temperature	0...70 °C
Protection degree	IP67
Approval/Conformity	CE

Appropriate data carrier

	BIS0033			BIS0036			BIS0039			BIS003R BIS0035			BIS003T BIS0038			
Data carrier distance to metal	metal-free	on metal	flush in metal	metal-free	on metal	flush in metal	metal-free	on metal	flush in metal	metal-free	on metal	flush in metal	metal-free	on metal	flush in metal	
Data carrier clear zone																
Working distance for writing	0-30	10-20	10-20	0-40	10-30	10-30	0-55	15-40	15-40							
Working distance for reading	0-30	10-20	10-20	0-40	10-30	10-30	0-55	15-40	15-40	0-40	10-25	10-20	0-50	10-35	10-30	
Offset at distance																
	0	±18		±28			±30			±20			±28			
	3	±18		±28			±30			±20			±28			
	7	±18		±28			±30			±20			±28			
	8	±18		±28			±30			±20			±28			
	10	±18	±8	±8	±28	±15	±13	±30		±20	±15	±10	±28	±20	±17	
	12	±18	±8	±8	±28	±15	±13	±30		±20	±15	±10	±28	±20	±17	
	15	±18	±5	±5	±28	±15	±10	±30	±20	±20	±20	±10	±10	±28	±20	±17
	18	±18	±2	±2	±28	±15	±10	±30	±20	±18	±20	±10	±10	±28	±20	±17
	20	±18	±0	±0	±28	±15	±10	±30	±20	±15	±20	±10	±0	±28	±20	±17
	25	±18			±28	±10	±5	±30	±15	±15	±20	±0		±28	±20	±15
	30	±18			±28	±0	±0	±30	±15	±10	±20			±28	±15	±0
	35				±28			±30	±15	±0	±20			±28	±0	
	40				±28			±30	±0		±20			±28		
	45							±30						±28		
	50							±30						±28		
	55							±0								
	60															
	70															
Dimensions in mm																

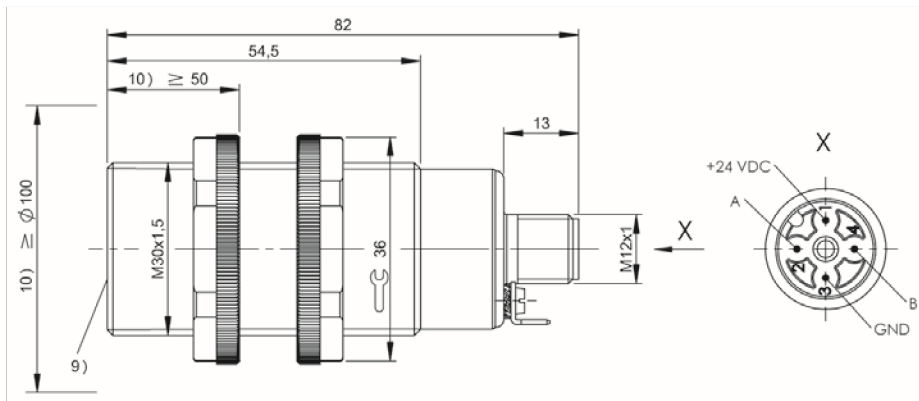

9) Sensing surface, 10) Clear zone

BIS003U BIS003C			BIS003W BIS003F		
metal-free	on metal	flush in metal	metal-free	on metal	flush in metal
0-70	15-45	15-40	0-25	3-12	3-10
±35			±15		
±35			±15	±12	±9
±35			±15	±12	±8
±35			±15	±12	±8
±35			±15	±9	±7
±35			±15	±0	
±35	±25	±20	±15		
±35	±25	±20	±15		
±35	±25	±20	±15		
±35	±20	±20	±13		
±35	±20	±20			
±35	±15	±15			
±35	±12	±0			
±35	±0				
±35					
±35					
±35					
±35					



	BIS00U6 BIS VL-301-001-S4
Product Group	LF (125 kHz)
Dimension	80 x 80 x 40 mm
Installation	metal-free (clear zone)
Antenna type	round
Connection	M12x1 connector, 4-pin
Housing material	PBT
Interface	—
Operating voltage U_b	—
Storage temperature	-20...85 °C
Ambient temperature	0...70 °C
Protection degree	IP67
Approval/Conformity	CE

Appropriate data carrier

	BIS0033			BIS0036			BIS0039			BIS003N BIS017H	BIS003R BIS0035			
	metal-free	on metal	flush in metal	metal-free	on metal	flush in metal	metal-free	on metal	flush in metal	metal-free	metal-free	on metal	flush in metal	
Data carrier distance to metal														
Data carrier clear zone														
Working distance for writing	0-40	15-30	15-25	0-55	15-40	15-35	0-70	20-50	20-50	0-32				
Working distance for reading	0-40	15-30	15-25	0-55	15-40	15-35	0-70	20-50	20-50	0-32	0-70	20-50	20-50	
Offset at distance														
	0	±30		±35			±40			±24	±40			
	3	±30		±35			±40			±24	±40			
	7	±30		±35			±40			±24	±40			
	8	±30		±35			±40			±24	±40			
	10	±30		±35			±40			±24	±40			
	12	±30		±35			±40			±24	±40			
	15	±30	±20	±15	±35	±20	±20	±40		±24	±40			
	18	±30	±15	±10	±35	±20	±20	±40		±24	±40			
	20	±30	±15	±10	±35	±20	±20	±40	±25	±22	±24	±40	±25	±22
	25	±30	±10	±0	±35	±20	±15	±40	±25	±22	±24	±40	±25	±22
	30	±30	±0		±35	±20	±15	±40	±25	±22	±24	±40	±25	±22
	35	±30			±35	±15	±0	±40	±20	±15		±40	±20	±15
	40	±30			±35	±0		±40	±15	±15		±40	±15	±15
	45				±35			±40	±15	±10		±40	±15	±10
	50				±35			±40	±0	±0		±40	±0	±0
	55				±35			±40				±40		
	60							±40				±40		
	70							±40				±40		
Dimensions in mm														

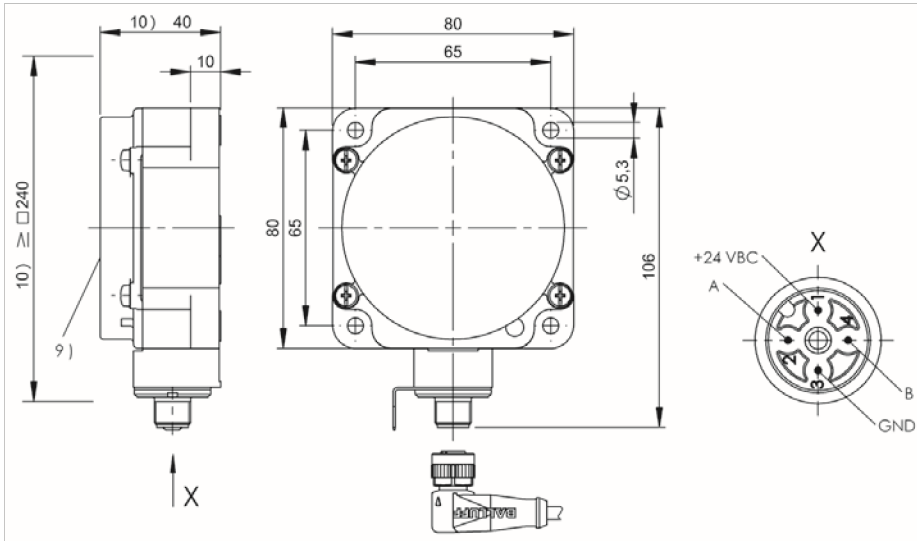

9) Sensing surface, 10) Clear zone

BIS003T BIS0038			BIS003U BIS003C		
metal-free	on metal	flush in metal	metal-free	on metal	flush in metal
0-70	20-45	20-40	0-100	25-60	25-55
±40			±45		
±40			±45		
±40			±45		
±40			±45		
±40			±45		
±40			±45		
±40			±45		
±40	±24	±20	±45	±30	±30
±40	±24	±20	±45	±30	±30
±40	±20	±20	±45	±30	±25
±40	±20	±15	±45	±30	±25
±40	±18	±0	±45	±25	±20
±40	±0		±45	±20	±20
±40			±45	±10	±0
±40			±45	±0	
±40			±45		
±40			±45		



	BISO15U BIS VL-308-001-S4
Product Group	LF (125 kHz)
Dimension	90 x 51 x 160 mm
Installation	metal-free (clear zone)
Antenna type	round
Connection	M12x1 connector, 4-pin
Housing material	ABS
Interface	—
Operating voltage U_b	—
Storage temperature	-20...85 °C
Ambient temperature	0...70 °C
Protection degree	IP67
Approval/Conformity	CE

Suitable data carriers on request

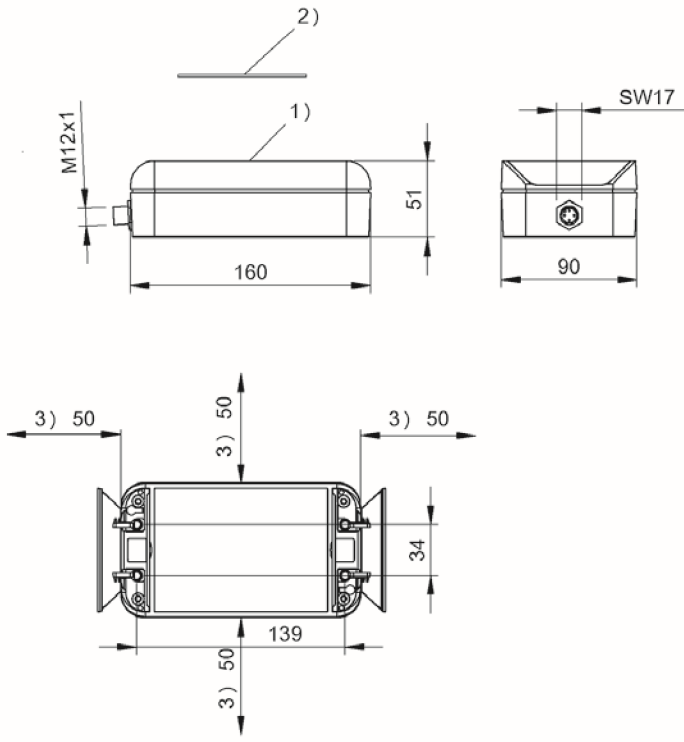

1) Sensing surface, 2) Data carrier, 3) Clear zone



	BIS000J BIS VL-306-001-S4
Product Group	LF (125 kHz)
Dimension	Ø 12 x 42.5 mm
Installation	metal-free (clear zone)
Antenna type	round
Connection	M12x1-Male, 4-pole, 0.50 m, PU1
Housing material	Brass, interface aluminum
Interface	—
Operating voltage U_b	—
Storage temperature	-20...85 °C
Ambient temperature	0...70 °C
Protection degree	IP67
Approval/Conformity	CE

Appropriate data carrier

	BIS0034	BIS003E	BIS003W BIS003F
Data carrier distance to metal	metal-free	metal-free	metal-free
Data carrier clear zone			
Working distance for writing	0-12	0-7	
Working distance for reading	0-12	0-7	0-7
Offset at distance			
	0 ±7	±4	±4
	3 ±7	±4	±4
	7 ±7	±4	±2
	8 ±7		
	10 ±7		
	12 ±7		
	15		
	18		
	20		
	25		
	30		
	35		
	40		
Dimensions in mm			

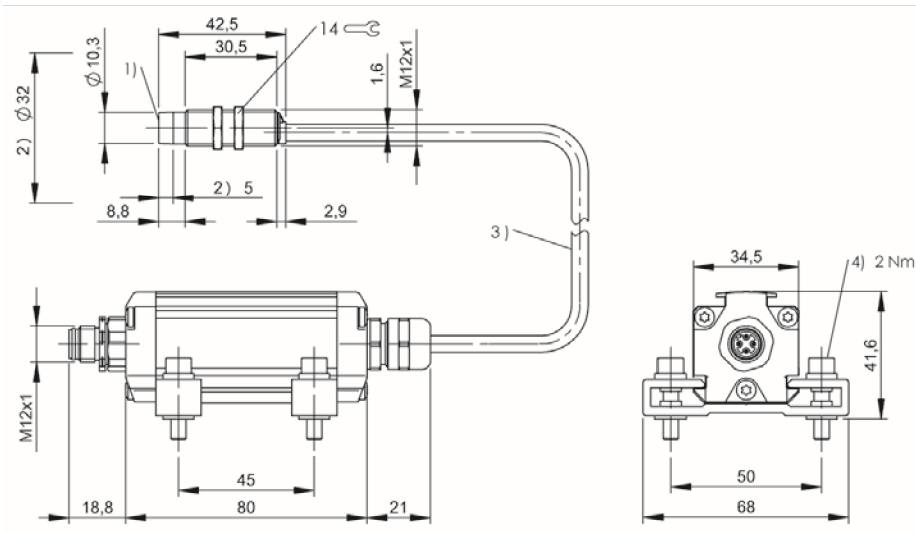

1) Sensing surface, 2) Clear zone, 3) Cable length see text, 4) Tightening torque



	BIS00UF BIS VL-302-001-S4
Product Group	LF (125 kHz)
Dimension	Ø 18 x 75 mm
Installation	metal-free (clear zone)
Antenna type	round
Connection	M12x1-Male, 4-pole, 0.50 m, PVC
Housing material	Brass, interface aluminum
Interface	—
Operating voltage U_b	—
Storage temperature	-20...85 °C
Ambient temperature	0...70 °C
Protection degree	IP67
Approval/Conformity	CE

Appropriate data carrier

	BIS0033			BIS0036			BIS0039			BIS003R BIS0035			BIS003T BIS0038		
	metal-free	on metal	flush in metal	metal-free	on metal	flush in metal	metal-free	on metal	flush in metal	metal-free	on metal	flush in metal	metal-free	on metal	flush in metal
Data carrier distance to metal															
Data carrier clear zone															
Working distance for writing	0-20	8-15	8-15	0-25	10-20	10-20	0-30	10-25	10-20						
Working distance for reading	0-20	8-15	8-15	0-25	10-20	10-20	0-30	10-25	10-20	0-25	8-15	8-15	0-30	10-20	10-20
Offset at distance															
	0 ±10			±12			±15			0 ±13			±15		
	3 ±10			±12			±15			3 ±13			±15		
	7 ±10			±12			±15			4 ±13			±15		
	8 ±10	±6	±6	±12			±15			8 ±13	±8	±6	±15		
	10 ±10	±5	±5	±12	±10	±8	±15	±15	±10	10 ±13	±8	±6	±15	±10	±10
	12 ±10	±4	±4	±12	±10	±8	±15	±15	±10	12 ±13	±8	±6	±15	±10	±10
	15 ±10	±0	±0	±12	±5	±5	±15	±15	±5	15 ±13	±0	±0	±15	±10	±8
	18 ±10			±12	±0	±0	±15	±10	±0	18 ±13			±15	±0	±0
	20 ±10			±12	±0	±0	±15	±10	±0	20 ±13			±15	±0	±0
	25			±12			±15	±0		25 ±13			±15		
	30						±15			30			±15		
	35									35					
	40									40					
Dimensions in mm															

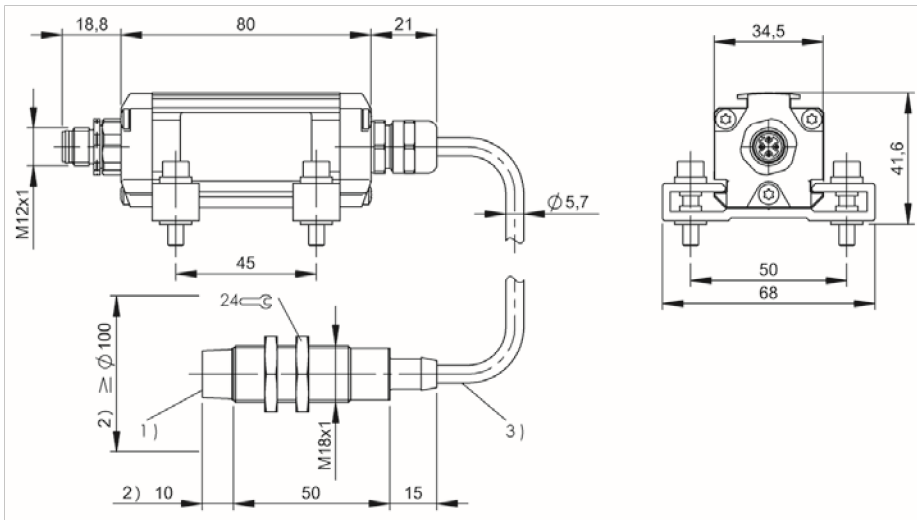

1) Sensing surface, 2) Clear zone, 3) Cable length

BIS003U BIS003C			BIS003W BIS003F		
metal-free	on metal	flush in metal	metal-free	on metal	flush in metal
0-40	10-25	10-20	0-15	4-10	3-8
±20			±6		
±20			±6		±5
±20			±6	±7	±4
±20			±6	±6	±3
±20	±15	±8	±6	±5	
±20	±15	±8	±6		
±20	±15	±6	±6		
±20	±10	±0			
±20	±10	±0			
±20	±0				
±20					
±20					
±20					



BIS000K BIS VL-350-001-S4	
Product Group	LF (125 kHz)
Dimension	12 x 26 x 40 mm
Installation	metal-free (clear zone)
Antenna type	Rod
Connection	M12x1-Male, 4-pole, 0.50 m, PU
Housing material	ABS, GF16, interface aluminum
Interface	—
Operating voltage U_b	—
Storage temperature	-20...85 °C
Ambient temperature	0...70 °C
Protection degree	IP67
Approval/Conformity	CE

Appropriate data carrier

Data carrier distance to metal	BIS003N		
	metal-free	on metal	flush in metal
Data carrier clear zone			
Working distance for writing	0-17	0-24	0-24
Working distance for reading	0-17	0-24	0-24
Offset at distance			
	0 ±18	±20	±20
	3 ±18	±20	±20
	7 ±18	±20	±20
	8 ±18	±20	±20
	10 ±18	±20	±20
	12 ±10	±20	±20
	15 ±10	±20	±20
	18	±14	±14
	20	±14	±14
	25	±14	±14
Dimensions in mm			

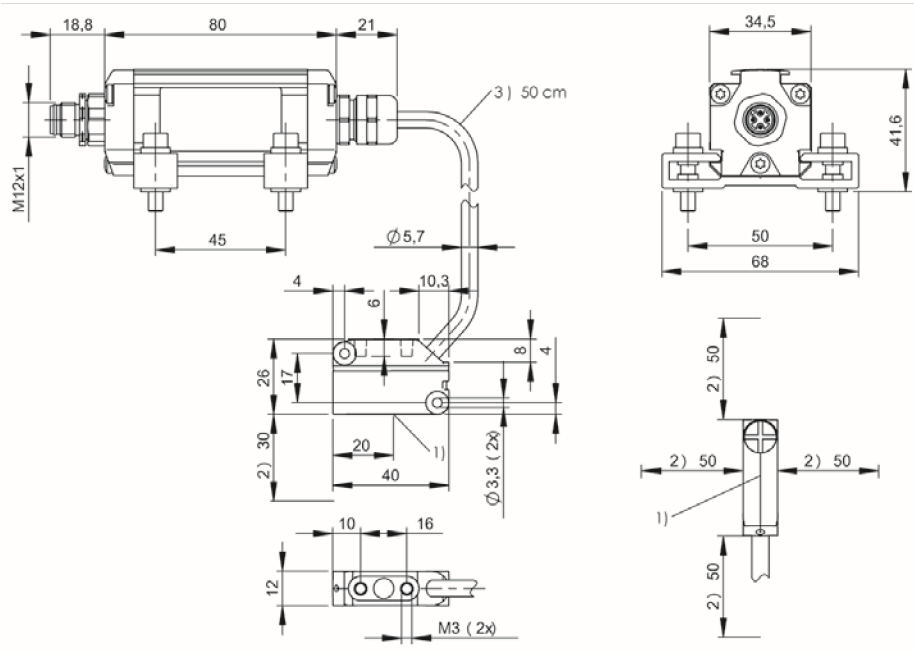

1) Sensing surface, 2) Clear zone, 3) Cable length



	BIS00UH BIS VL-304-001-S4
Product Group	LF (125 kHz)
Dimension	25 x 10 x 50 mm
Installation	metal-free (clear zone)
Antenna type	round
Connection	M12x1-Male, 4-pole, 0.50 m, PU
Housing material	ABS, GF16, interface aluminum
Interface	—
Operating voltage U_b	—
Storage temperature	-20...85 °C
Ambient temperature	0...70 °C
Protection degree	IP67
Approval/Conformity	CE

Appropriate data carrier

	BIS0033			BIS0036			BIS0039				BIS003R BIS0035			BIS003T BIS0038			
	metal-free	on metal	flush in metal	metal-free	on metal	flush in metal	metal-free	on metal	flush in metal		metal-free	on metal	flush in metal	metal-free	on metal	flush in metal	
Data carrier distance to metal																	
Data carrier clear zone																	
Working distance for writing	0-20	8-15	8-15	0-25	10-20	10-20	0-30	10-25	10-20								
Working distance for reading	0-20	8-15	8-15	0-25	10-20	10-20	0-30	10-25	10-20								
Offset at distance																	
	0	±10		±12			±15				0	±13		±15			
	3	±10		±12			±15				3	±13		±15			
	7	±10		±12			±15				4	±13		±15			
	8	±10	±6	±6	±12		±15				8	±13	±8	±6	±15		
	10	±10	±5	±5	±12	±10	±8	±15	±15	±10	10	±13	±8	±6	±15	±10	±10
	12	±10	±3	±3	±12	±10	±8	±15	±15	±10	12	±13	±8	±6	±15	±10	±10
	15	±10	±0	±0	±12	±5	±5	±15	±15	±5	15	±13	±0	±0	±15	±10	±8
	18	±10			±12	±0	±0	±15	±10	±0	18	±13			±15	±0	±0
	20	±10			±12	±0	±0	±15	±10	±0	20	±13			±15	±0	±0
	25				±12			±15	±0		25	±13			±15		
	30							±15			30				±15		
	35										35						
	40										40						
Dimensions in mm																	

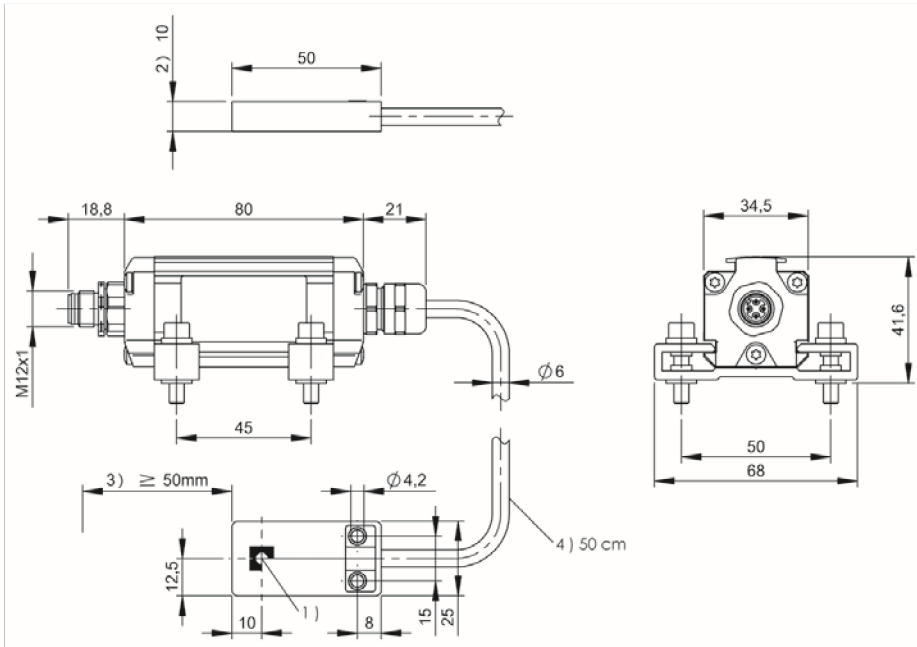

1) Sensing surface, 2) Clear zone, 3) Clear zone surrounding, 4) Cable length

BIS003U BIS003C			BIS003W BIS003F		
metal-free	on metal	flush in metal	metal-free	on metal	flush in metal
0-40	10-25	10-20	0-15	4-10	3-8
±20			±6		
±20			±6		±5
±20			±6	±7	±3
±20			±6	±6	±3
±20	±15	±8	±6	±5	
±20	±15	±8	±6		
±20	±15	±6	±6		
±20	±10	±0			
±20	±10	±0			
±20	±0				
±20					
±20					
±20					



For read/write heads BIS VM (HF 13.56 MHz), BIS VL (LF 125 kHz) and BIS VU (UHF 860/960 MHz) *	BISO13U BIS V-6108-048-C002	
Product Group	Multi-Frequency Processors (BIS V)	
Interface	Profinet I/O (IRT), 2 port Switch	
Supported RFID technologies	LF 125 kHz (BIS VL), HF 13.56 MHz (BIS VM), UHF 860/960 MHz (BIS VU)	
Number of connectable R/W heads / antennas	4	
Operating voltage Ub	24 V DC LPS Class 2	
Housing material	Zinc, die-cast	
Ambient temperature	0...60 °C	
Protection degree	IP65 with connector	
Approval/Conformity	CE, UL Listed	
Connection	2x M12x1-Female, 4-pole, D-coded 7/8"-Male, 5-pole	
Productview	Page 472	

* Use adapter **BISOFCK** to connect read/write heads **BIS C (LF 70/455 kHz)**.



BIS013W BIS V-6108-048-C102	BIS00T3 BIS V-6102-019-C001	BIS012E BIS V-6102-019-C101
Multi-Frequency Processors (BIS V)	Multi-Frequency Processors (BIS V)	Multi-Frequency Processors (BIS V)
Profinet I/O (IRT), 2 port Switch	Profibus DP Slave galvanically isolated	Profibus DP Slave galvanically isolated
LF 125 kHz (BIS VL), LF 70/455 kHz (BIS C), HF 13.56 MHz (BIS VM), UHF 860/960 MHz (BIS VU)	LF 125 kHz (BIS VL), HF 13.56 MHz (BIS VM), UHF 860/960 MHz (BIS VU)	LF 125 kHz (BIS VL), LF 70/455 kHz (BIS C), HF 13.56 MHz (BIS VM), UHF 860/960 MHz (BIS VU)
4	4	4
24 V DC LPS Class 2	24 V DC LPS Class 2	24 V DC LPS Class 2
Zinc, die-cast	Zinc, die-cast	Zinc, die-cast
0...60 °C	0...60 °C	0...60 °C
IP65 with connector	IP65 with connector	IP65 with connector
CE, UL Listed	CE, UL Listed	CE, UL Listed
2x M12x1-Female, 4-pole, D-coded 7/8"-Male, 5-pole	M12x1-Male, 5-pole, B-coded M12x1-Female, 5-pole, B-coded 7/8"-Male, 5-pole	M12x1-Male, 5-pole, B-coded M12x1-Female, 5-pole, B-coded 7/8"-Male, 5-pole
Page 472	Page 472	Page 472



For read/write heads BIS VM (HF 13.56 MHz), BIS VL (LF 125 kHz) and BIS VU (UHF 860/960 MHz) *	BIS0186 BIS V-6107-039-C005	
Product Group	Multi-Frequency Processors (BIS V)	
Interface	Ethernet TCP/IP, USB	
Supported RFID technologies	LF 125 kHz (BIS VL), HF 13.56 MHz (BIS VM), UHF 860/960 MHz (BIS VU)	
Number of connectable R/W heads / antennas	4	
Operating voltage U _b	24 V DC LPS Class 2	
Housing material	Zinc, die-cast	
Ambient temperature	0...60 °C	
Protection degree	IP65 with connector	
Approval/Conformity	CE, UL Listed	
Connection	M12x1-Female, 4-pole, D-coded M12x1-Female, 5-pole, A-coded 7/8"-Male, 5-pole	
Productview	Page 473	

* Use adapter **BISOFCK** to connect read/write heads **BIS C (LF 70/455 kHz)**.



BIS018J BIS V-6107-039-C006	BIS0187 BIS V-6107-039-C105	BIS018K BIS V-6107-039-C106
Multi-Frequency Processors (BIS V)	Multi-Frequency Processors (BIS V)	Multi-Frequency Processors (BIS V)
Ethernet TCP/IP, USB	Ethernet TCP/IP, USB	Ethernet TCP/IP, USB
LF 125 kHz (BIS VL), HF 13.56 MHz (BIS VM), UHF 860/960 MHz (BIS VU)	LF 125 kHz (BIS VL), LF 70/455 kHz (BIS C), HF 13.56 MHz (BIS VM), UHF 860/960 MHz (BIS VU)	LF 125 kHz (BIS VL), LF 70/455 kHz (BIS C), HF 13.56 MHz (BIS VM), UHF 860/960 MHz (BIS VU)
4	4	4
24 V DC LPS Class 2	24 V DC LPS Class 2	24 V DC LPS Class 2
Zinc, die-cast	Zinc, die-cast	Zinc, die-cast
0...60 °C	0...60 °C	0...60 °C
IP65 with connector	IP65 with connector	IP65 with connector
CE, UL Listed	CE, UL Listed	CE, UL Listed
M12x1-Female, 4-pole, D-coded M12x1-Female, 5-pole, A-coded 7/8"-Male, 4-pole	M12x1-Female, 4-pole, D-coded M12x1-Female, 5-pole, A-coded 7/8"-Male, 5-pole	M12x1-Female, 4-pole, D-coded M12x1-Female, 5-pole, A-coded 7/8"-Male, 4-pole
Page 473	Page 473	Page 473



For read/write heads BIS VM (HF 13.56 MHz), BIS VL (LF 125 kHz) and BIS VU (UHF 860/960 MHz) *	BIS012F BIS V-6106-034-C002	
Product Group	Multi-Frequency Processors (BIS V)	
Interface	Ethernet/IP	
Supported RFID technologies	LF 125 kHz (BIS VL), HF 13.56 MHz (BIS VM), UHF 860/960 MHz (BIS VU)	
Number of connectable R/W heads / antennas	4	
Operating voltage U _b	24 V DC LPS Class 2	
Housing material	Zinc, die-cast	
Ambient temperature	0...60 °C	
Protection degree	IP65 with connector	
Approval/Conformity	CE, UL Listed	
Connection	2x M12x1-Female, 4-pole, D-coded 7/8"-Male, 5-pole	
Productview	Page 474	

* Use adapter **BIS0FCK** to connect read/write heads **BIS C (LF 70/455 kHz)**.



BIS0122 BIS V-6106-034-C004	BIS014C BIS V-6106-034-C102	BIS0146 BIS V-6106-034-C104
Multi-Frequency Processors (BIS V)	Multi-Frequency Processors (BIS V)	Multi-Frequency Processors (BIS V)
Ethernet/IP	Ethernet/IP	Ethernet/IP
LF 125 kHz (BIS VL), HF 13.56 MHz (BIS VM), UHF 860/960 MHz (BIS VU)	LF 125 kHz (BIS VL), LF 70/455 kHz (BIS C), HF 13.56 MHz (BIS VM), UHF 860/960 MHz (BIS VU)	LF 125 kHz (BIS VL), LF 70/455 kHz (BIS C), HF 13.56 MHz (BIS VM), UHF 860/960 MHz (BIS VU)
4	4	4
24 V DC LPS Class 2	24 V DC LPS Class 2	24 V DC LPS Class 2
Zinc, die-cast	Zinc, die-cast	Zinc, die-cast
0...60 °C	0...60 °C	0...60 °C
IP65 with connector	IP65 with connector	IP65 with connector
CE, UL Listed	CE, UL Listed	CE, UL Listed
2x M12x1-Female, 4-pole, D-coded 7/8"-Male, 4-pole	2x M12x1-Female, 4-pole, D-coded 7/8"-Male, 5-pole	2x M12x1-Female, 4-pole, D-coded 7/8"-Male, 4-pole
Page 474	Page 474	Page 474



For read/write heads BIS VM (HF 13.56 MHz), BIS VL (LF 125 kHz) and BIS VU (UHF 860/960 MHz) *	BIS00U9 BIS V-6110-063-C002	
Product Group	Multi-Frequency Processors (BIS V)	
Interface	EtherCAT	
Supported RFID technologies	LF 125 kHz (BIS VL), HF 13.56 MHz (BIS VM), UHF 860/960 MHz (BIS VU)	
Number of connectable R/W heads / antennas	4	
Operating voltage U _b	24 V DC LPS Class 2	
Housing material	Zinc, die-cast	
Ambient temperature	0...60 °C	
Protection degree	IP65 with connector	
Approval/Conformity	CE, UL Listed	
Connection	2x M12x1-Female, 4-pole, D-coded 7/8"-Male, 5-pole	
Productview	Page 475	

* Use adapter **BIS0FCK** to connect read/write heads **BIS C (LF 70/455 kHz)**.



BIS0147 BIS V-6110-063-C102	BIS010P BIS V-6111-073-C003	BIS014E BIS V-6111-073-C103
Multi-Frequency Processors (BIS V)	Multi-Frequency Processors (BIS V)	Multi-Frequency Processors (BIS V)
EtherCAT	CC-Link	CC-Link
LF 125 kHz (BIS VL), LF 70/455 kHz (BIS C), HF 13.56 MHz (BIS VM), UHF 860/960 MHz (BIS VU)	LF 125 kHz (BIS VL), HF 13.56 MHz (BIS VM)	LF 125 kHz (BIS VL), LF 70/455 kHz (BIS C), HF 13.56 MHz (BIS VM)
4	4	4
24 V DC LPS Class 2	24 V DC LPS Class 2	24 V DC LPS Class 2
Zinc, die-cast	Zinc, die-cast	Zinc, die-cast
0...60 °C	0...60 °C	0...60 °C
IP65 with connector	IP65 with connector	IP65 with connector
CE, UL Listed	CE, UL Listed	CE, UL Listed
2x M12x1-Female, 4-pole, D-coded 7/8"-Male, 5-pole	M12x1-Male, 5-pole, A-coded M12x1-Female, 5-pole, A-coded 7/8"-Male, 5-pole	M12x1-Male, 5-pole, A-coded M12x1-Female, 5-pole, A-coded 7/8"-Male, 5-pole
Page 475	Page 475	Page 475



For read/write heads BIS L-400-043...	BAE003W BIS Z-EL-002-RS232	
Product Group	LF (125 kHz)	
Interface	RS232	
Supported RFID technologies	LF 125 kHz (BIS L, Easy Loop)	
Number of connectable R/W heads / antennas	16	
Operating voltage U_b	19.2...28.8 VDC	
Housing material	ABS	
Ambient temperature	0...60 °C	
Protection degree	IP65 with connector	
Approval/Conformity	CE	
Connection	Male, 4-pole Male, 5-pole	
Productview	Page 476	



BAE003U BIS Z-EL-001-ETHERNET		
LF (125 kHz)		
Ethernet TCP/IP		
LF 125 kHz (BIS L, Easy Loop)		
16		
19.2...28.8 VDC		
ABS		
0...60 °C		
IP65 with connector		
CE		
Female, 4-pole, D-coded Male, 5-pole		
Page 476		

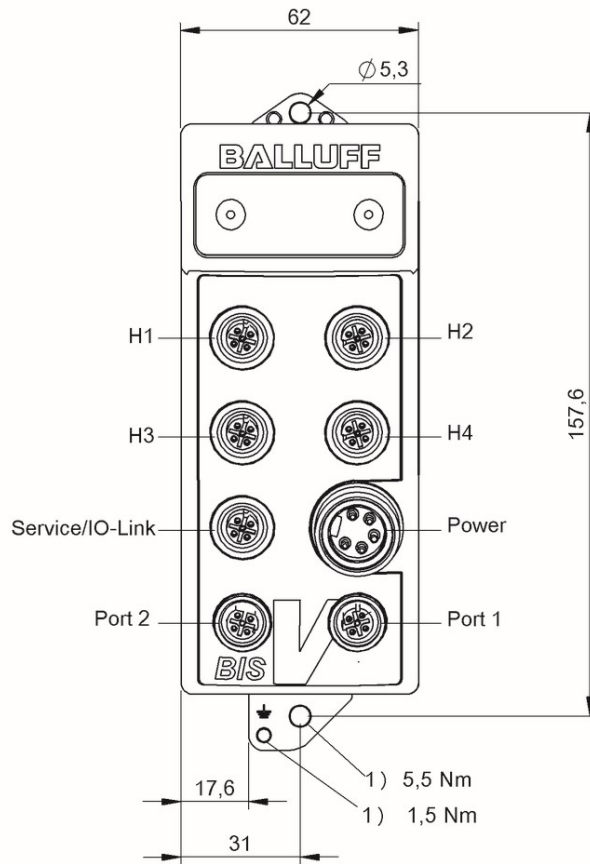
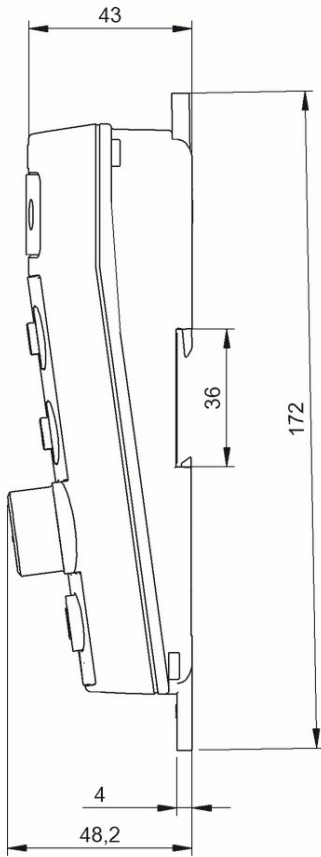

1) Tightening torque

BIS013U, BIS013W

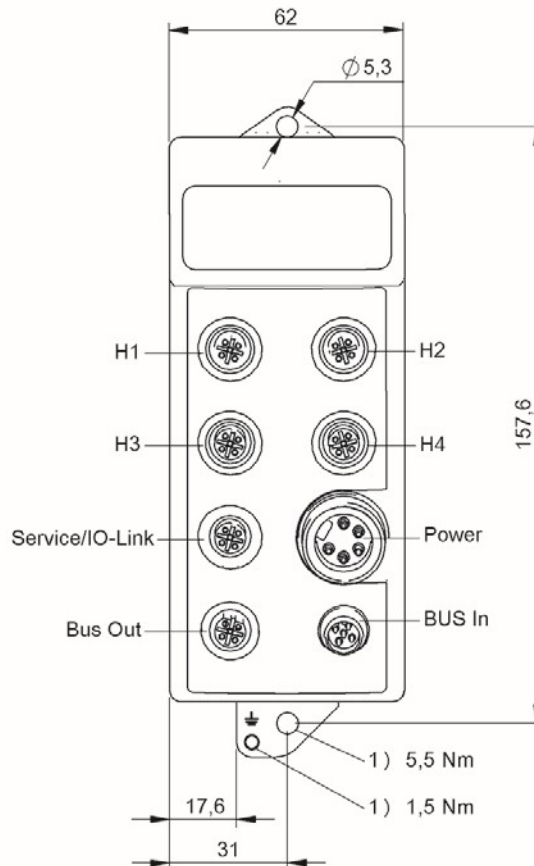
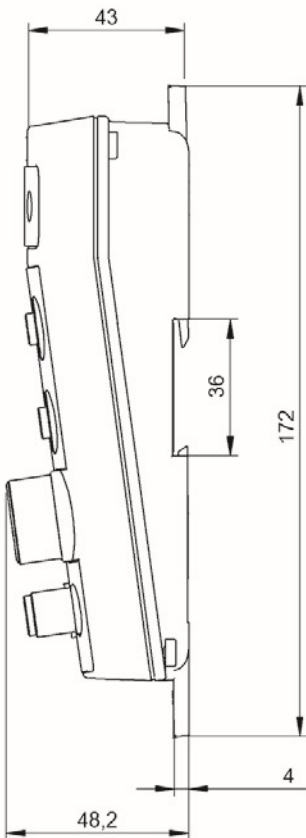

1) Tightening torque

BIS00T3, BIS012E

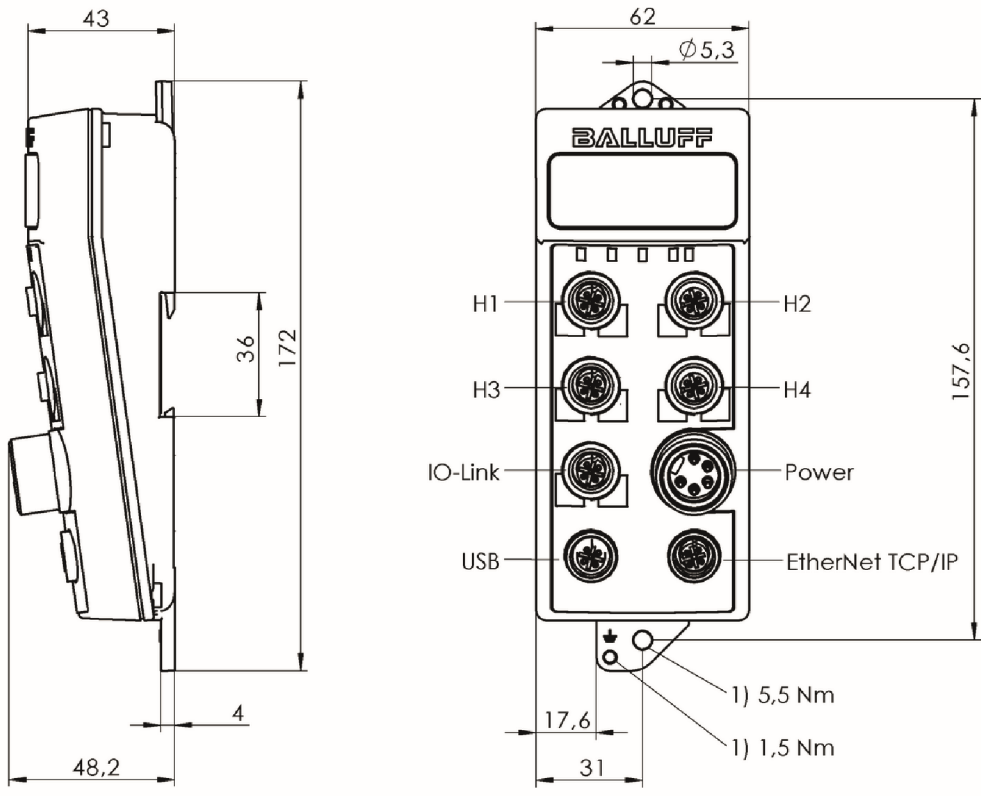

1) Tightening torque

BIS0186, BIS0187

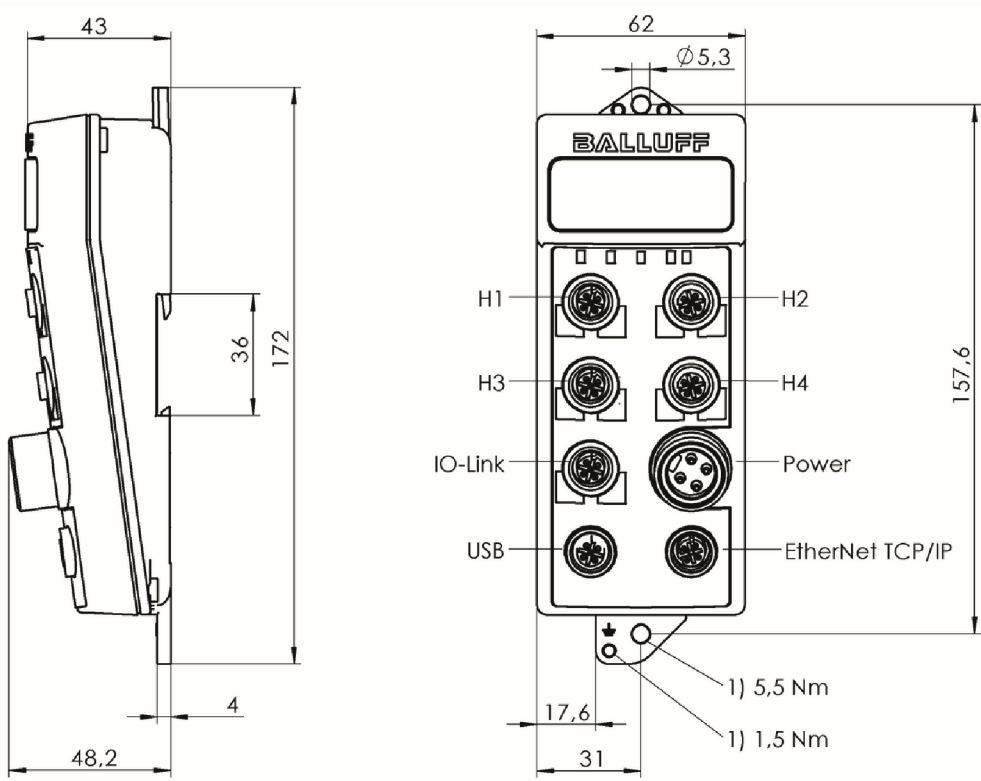

1) Tightening torque

BIS018J, BIS018K

Do you need more details? Our Product Finder at www.balluff.com provides you with product-specific information, including technical drawings, data sheets, user guides and more for each individual product. All items are available for download.

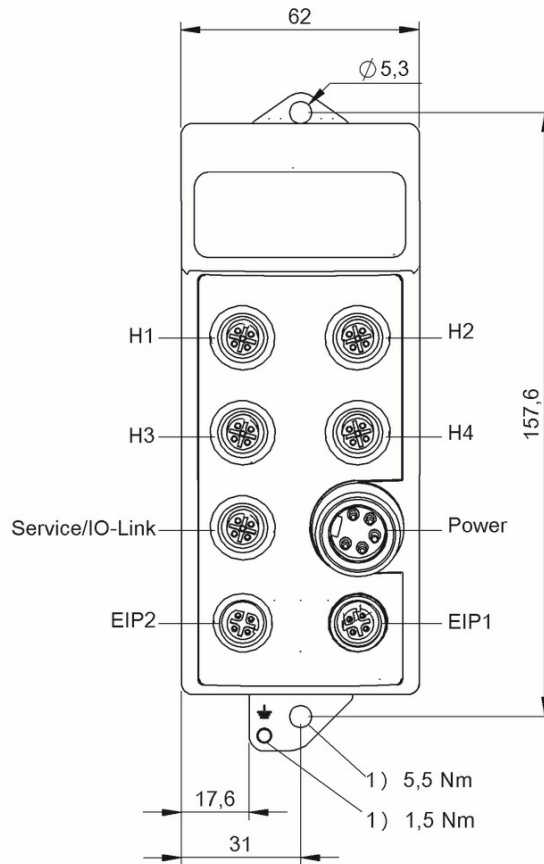
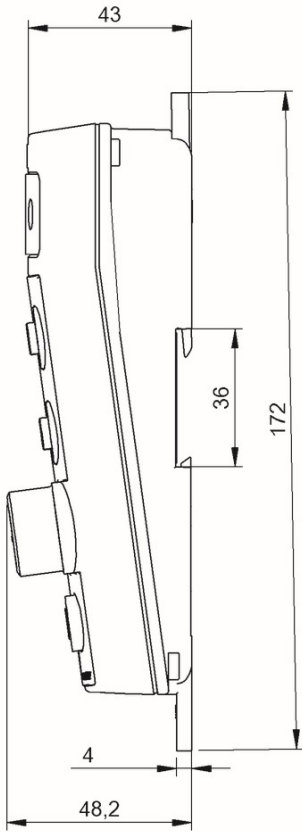

1) Tightening torque

BIS012F, BIS014C

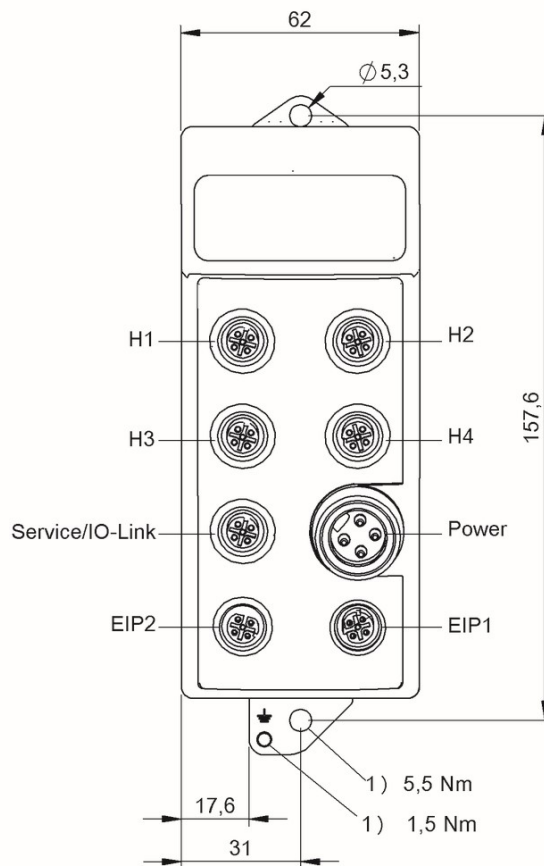
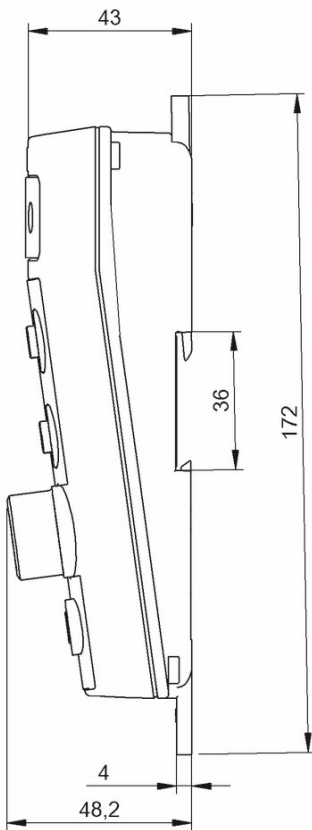

1) Tightening torque

BIS0122, BIS0146

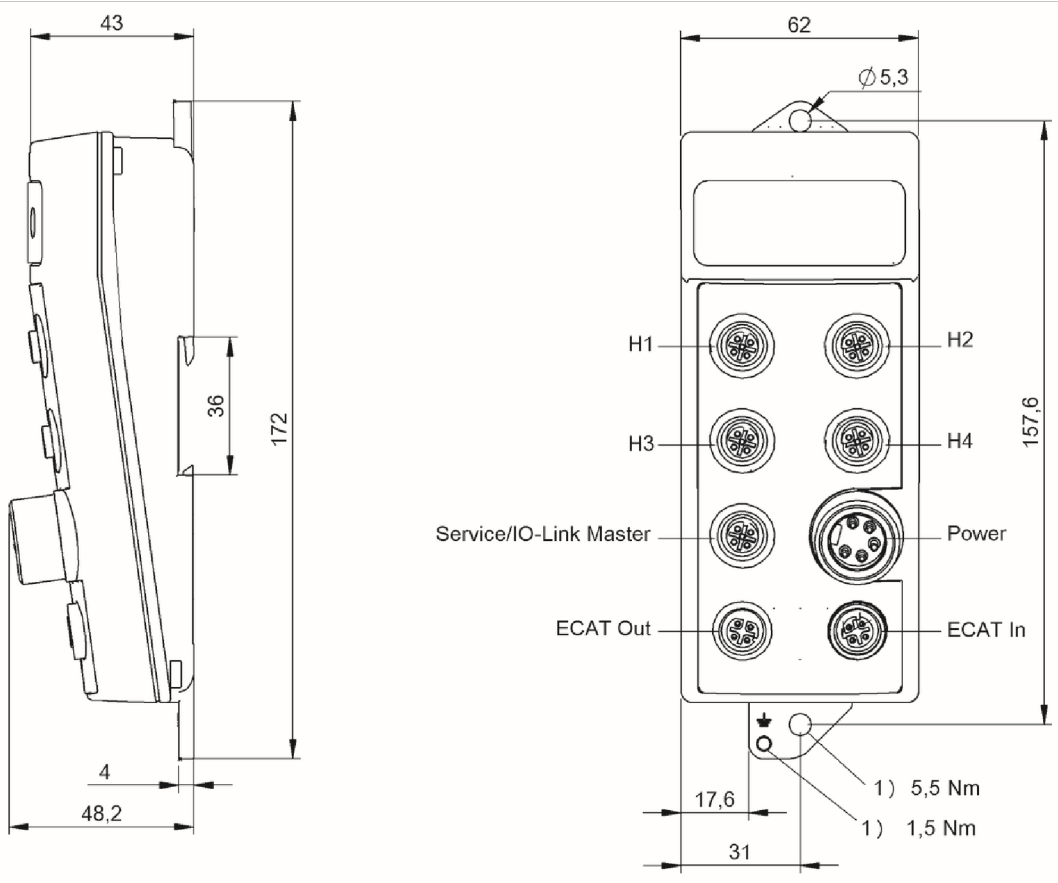

1) Tightening torque

BISO0U9, BISO147

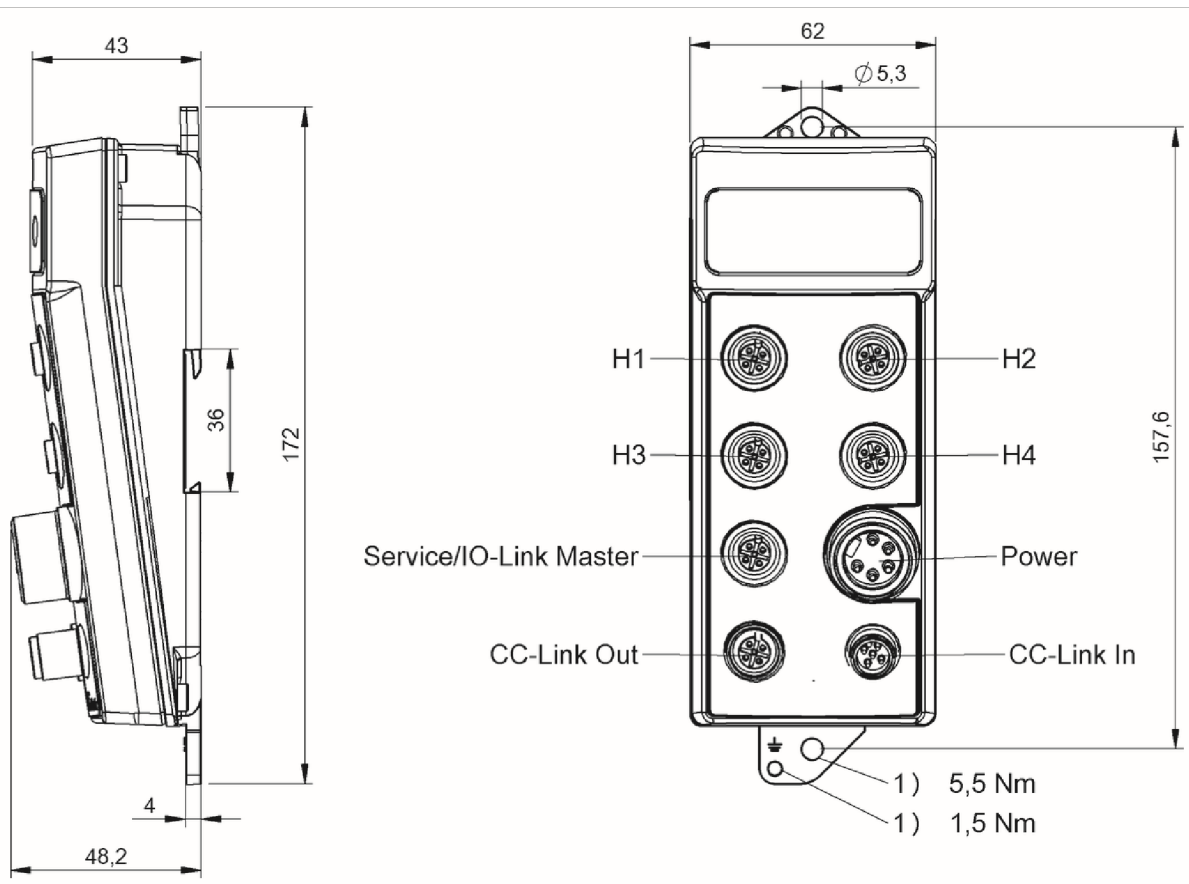

1) Tightening torque

BISO10P, BISO14E

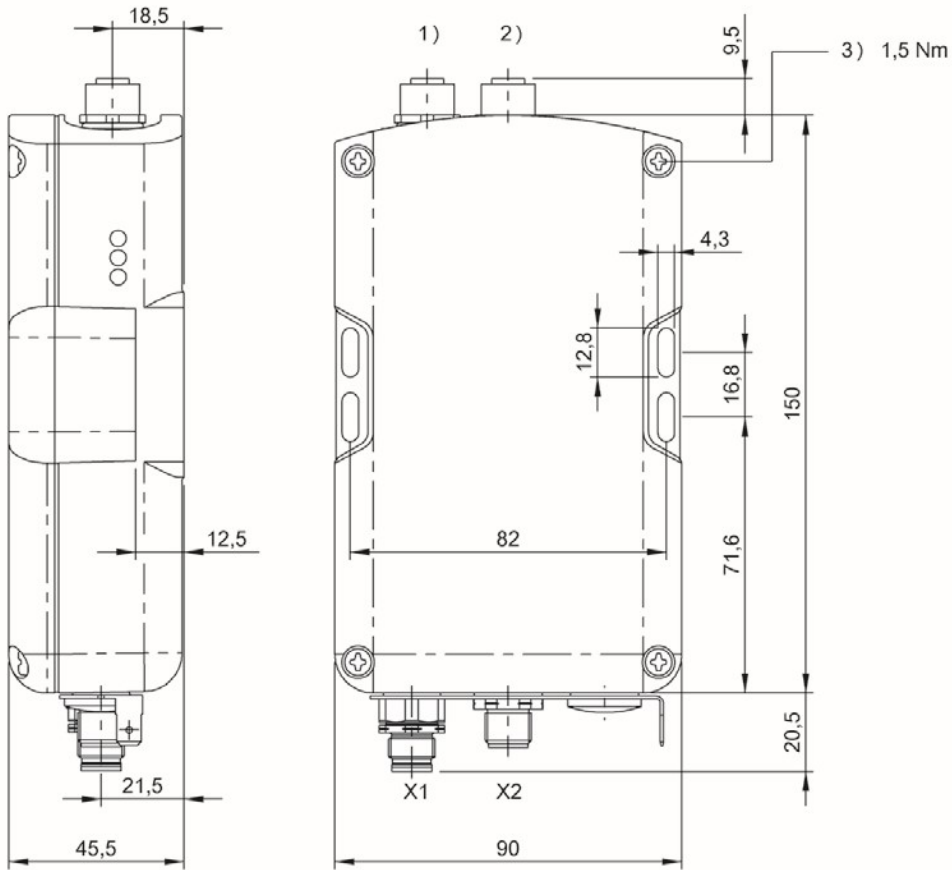

1) Line 1, 2) Line 2, 3) Tightening torque

BAE003W

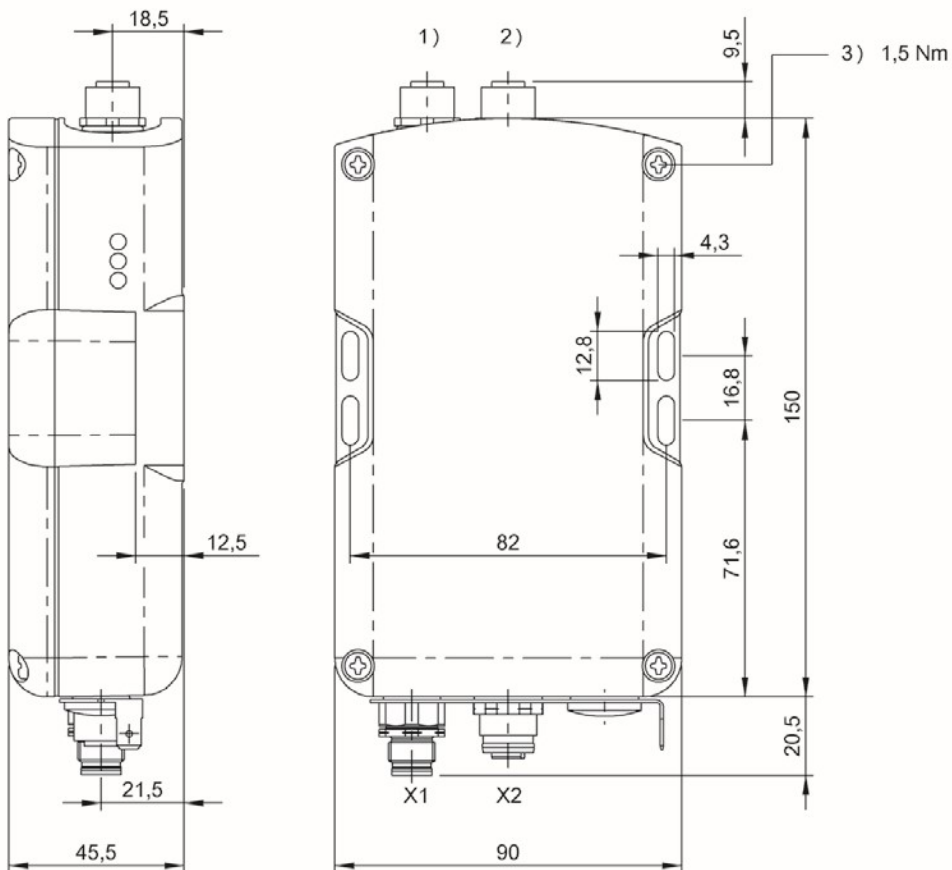

1) Line 1, 2) Line 2, 3) Tightening torque

BAE003U



	BIS00C5 BIS L-400-035-001-00-S115
Product Group	LF (125 kHz)
Dimension	40 x 41 x 120 mm
Installation	metal-free (clear zone)
Antenna type	round
Connection	Connector, M12x1 connector, 8-pin
Housing material	PBT
Interface	RS232
Operating voltage U_b	19.2...26.4 VDC
Ambient temperature	0...70 °C
Protection degree	IP67
Approval/Conformity	CE, UL-FILE E227256, Vol.X1, BIS

Appropriate data carrier

	BIS003R BIS0035			BIS003T BIS0038			BIS003U BIS003C			BIS003W BIS003F	
Data carrier distance to metal	metal-free	on metal	flush in metal	metal-free	on metal	flush in metal	metal-free	on metal	flush in metal	metal-free	
Data carrier clear zone											
Working distance for writing											
Working distance for reading	0-30	0-15	5-12	0-40	0-24	0-18	0-55	0-32	0-28	0-20	
Offset at distance											
	0	±15	±10		±20	±12	±10	±30	±20	±18	±10
	3	±15	±10		±20	±12	±10	±30	±20	±18	±10
	5	±15	±10	±10	±20	±12	±10	±30	±20	±18	±10
	8	±15	±10	±7	±20	±12	±10	±30	±20	±18	±10
	10	±15	±10	±7	±20	±12	±10	±30	±20	±18	±10
	12	±15	±8	±7	±20	±12	±10	±30	±20	±18	±10
	15	±15	±8		±20	±12	±10	±30	±20	±18	±10
	18	±15			±20	±12	±10	±30	±20	±14	
	20	±15			±20	±12		±30	±20	±14	
	24	±15			±20	±10		±30	±20	±12	
	28				±20			±30	±14	±12	
	30				±20			±30	±14		
	32				±20			±30	±14		
	35				±20			±30			
	40							±30			
Dimensions in mm											

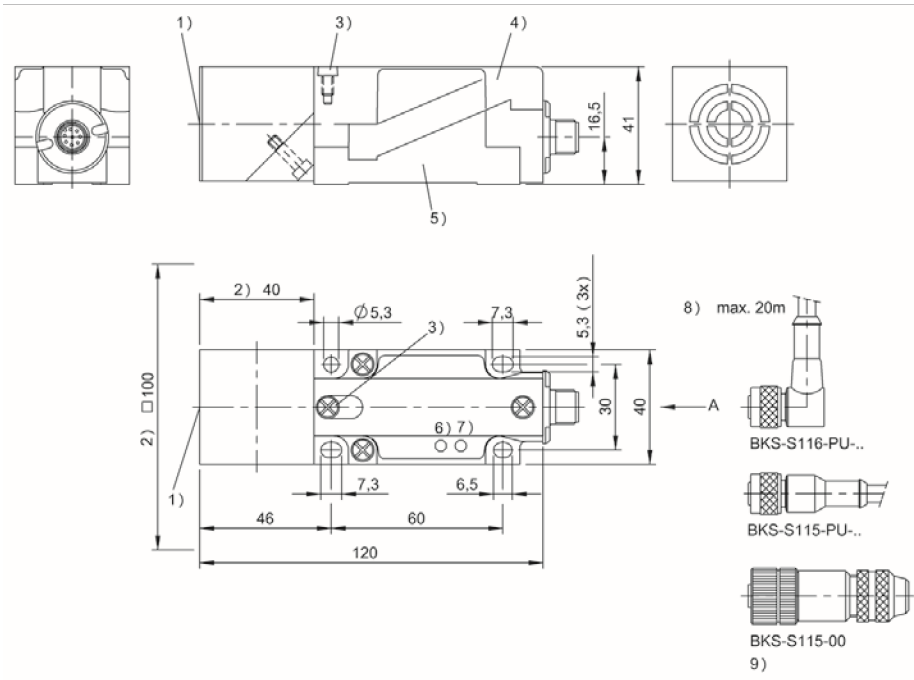

1) Sensing surface, 2) Clear zone, 3) Locking screw, 4) Module unit, 5) Mounting base, 6) Power, 7) Tag present, 8) Cable length, 9) no cable



	BIS00C7 BIS L-400-035-002-00-S115
Product Group	LF (125 kHz)
Dimension	Ø 18 x 75 mm
Installation	metal-free (clear zone)
Antenna type	round
Connection	Connector, M12x1 connector, 8-pin, 0.50 m, PU
Housing material	Brass, interface PBT
Interface	RS232
Operating voltage U_b	19.2...26.4 VDC
Ambient temperature	0...70 °C
Protection degree	IP67
Approval/Conformity	CE, UL-FILE E227256, Vol.X1, BIS

Appropriate data carrier

	BIS003R BIS0035	BIS003T BIS0038	BIS003W BIS003F
Data carrier distance to metal	metal-free	metal-free	metal-free
Data carrier clear zone			
Working distance for writing			
Working distance for reading	0-23	0-27	0-16
Offset at distance			
	0 ±12	±15	±8
	3 ±12	±15	±8
	7 ±12	±15	±8
	8 ±12	±15	±8
	10 ±12	±15	±8
	12 ±12	±15	±4
	15 ±12	±15	±4
	18	±15	
	20	±15	
	25	±6	
Dimensions in mm			

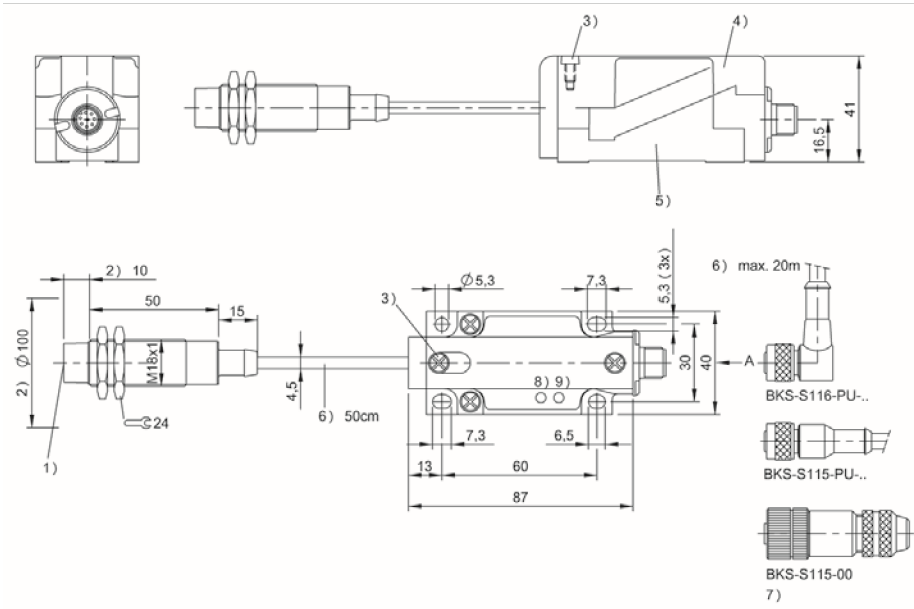

1) Sensing surface, 2) Clear zone, 3) Locking screw, 4) Module unit, 5) Mounting base, 6) Cable length, 7) no cable, 8) Power, 9) Tag present



	BIS00C9 BIS L-400-035-003-00-S115
Product Group	LF (125 kHz)
Dimension	Ø 12 x 53 mm
Installation	metal-free (clear zone)
Antenna type	round
Connection	Connector, M12x1 connector, 8-pin, 0.50 m, PU
Housing material	Brass, interface PBT
Interface	RS232
Operating voltage U_b	19.2...26.4 VDC
Ambient temperature	0...70 °C
Protection degree	IP67
Approval/Conformity	CE, UL-FILE E227256, Vol.X1, BIS

Appropriate data carrier

	BIS003W	BIS003F
Data carrier distance to metal	metal-free	
Data carrier clear zone		
Working distance for writing		
Working distance for reading	0-11	
Offset at distance		
	0	±6
	3	±6
	7	±4
	8	±4
	10	±2
Dimensions in mm		

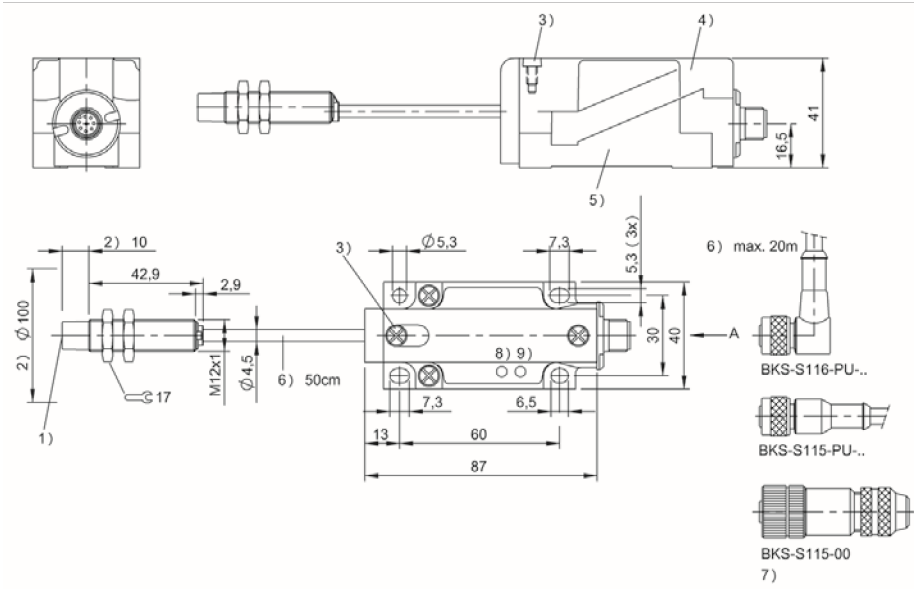

1) Sensing surface, 2) Clear zone, 3) Locking screw, 4) Module unit, 5) Mounting base, 6) Cable length, 7) no cable, 8) Power, 9) Tag present



BIS00CC BIS L-400-035-004-00-S115	
Product Group	LF (125 kHz)
Dimension	25 x 10 x 50 mm
Installation	metal-free (clear zone)
Antenna type	round
Connection	Connector, M12x1 connector, 8-pin, 0.50 m, PU
Housing material	ABS, interface PBT
Interface	RS232
Operating voltage U_b	19.2...26.4 VDC
Ambient temperature	0...70 °C
Protection degree	IP67
Approval/Conformity	CE, UL-FILE E227256, Vol.X1, BIS

Appropriate data carrier

	BIS003R BIS0035	BIS003T BIS0038	BIS003W BIS003F
Data carrier distance to metal	metal-free	metal-free	metal-free
Data carrier clear zone			
Working distance for writing			
Working distance for reading	0-23	0-27	0-16
Offset at distance			
	0 ±12	±15	±8
	3 ±12	±15	±8
	7 ±12	±15	±8
	8 ±12	±15	±8
	10 ±12	±15	±8
	12 ±12	±15	±4
	15 ±12	±15	±4
	18 ±8	±15	
	20 ±8	±15	
	25	±6	
Dimensions in mm			

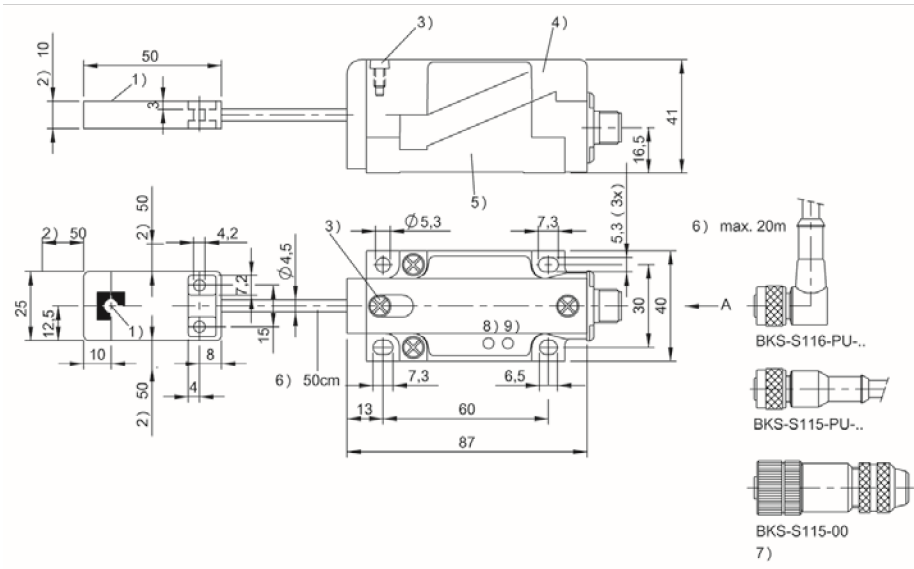

1) Sensing surface, 2) Clear zone, 3) Locking screw, 4) Module unit, 5) Mounting base, 6) Cable length, 7) no cable, 8) Power, 9) Tag present



	BIS00C6 BIS L-400-035-001-02-S115
Product Group	LF (125 kHz)
Dimension	40 x 41 x 120 mm
Installation	metal-free (clear zone)
Antenna type	round
Connection	Connector, M12x1 connector, 8-pin
Housing material	PBT
Interface	RS422
Operating voltage U_b	19.2...26.4 VDC
Ambient temperature	0...70 °C
Protection degree	IP67
Approval/Conformity	CE, UL-FILE E227256, Vol.X1, BIS

Appropriate data carrier

	BIS003R BIS0035			BIS003T BIS0038			BIS003U BIS003C			BIS003W BIS003F	
	metal-free	on metal	flush in metal	metal-free	on metal	flush in metal	metal-free	on metal	flush in metal	metal-free	
Data carrier distance to metal											
Data carrier clear zone											
Working distance for writing											
Working distance for reading	0-30	0-15	5-12	0-40	0-24	0-18	0-55	0-32	0-28	0-20	
Offset at distance											
	0	±15	±10		±20	±12	±10	±30	±20	±18	±10
	3	±15	±10		±20	±12	±10	±30	±20	±18	±10
	5	±15	±10	±10	±20	±12	±10	±30	±20	±18	±10
	8	±15	±10	±7	±20	±12	±10	±30	±20	±18	±10
	10	±15	±10	±7	±20	±12	±10	±30	±20	±18	±10
	12	±15	±8	±7	±20	±12	±10	±30	±20	±18	±10
	15	±15	±8		±20	±12	±10	±30	±20	±18	±10
	18	±15			±20	±12	±10	±30	±20	±14	
	20	±15			±20	±12		±30	±20	±14	
	24	±15			±20	±10		±30	±20	±12	
	28				±20			±30	±14	±12	
	30				±20			±30	±14		
	32				±20			±30	±14		
	35				±20			±30			
	40							±30			
Dimensions in mm											

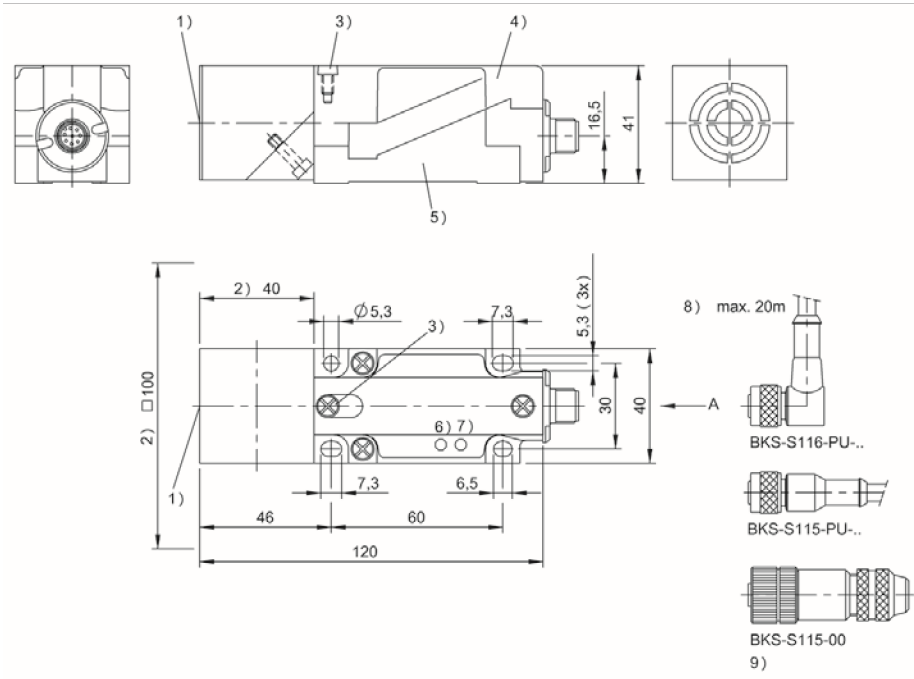

1) Sensing surface, 2) Clear zone, 3) Locking screw, 4) Module unit, 5) Mounting base, 6) Power, 7) Tag present, 8) Cable length, 9) no cable



IO-Link, 10 Bytes process data length	BIS00CZ BIS L-409-045-001-07-S4
Product Group	LF (125 kHz)
Dimension	40 x 41 x 120 mm
Installation	metal-free (clear zone)
Antenna type	round
Connection	Connector, M12x1 connector, 4-pin
Housing material	PBT
Interface	IO-Link
Operating voltage U_b	18...30 VDC
Ambient temperature	0...70 °C
Protection degree	IP67
Approval/Conformity	CE, UL-FILE E227256, Vol.X1, BIS

Nur mit **IO-Link-Master** verwenden

Appropriate data carrier

	BIS003R BIS0035			BIS003T BIS0038			BIS003U BIS003C			BIS003W BIS003F	
	metal-free	on metal	flush in metal	metal-free	on metal	flush in metal	metal-free	on metal	flush in metal	metal-free	
Data carrier distance to metal											
Data carrier clear zone											
Working distance for writing											
Working distance for reading	0-30	0-15	5-12	0-40	0-24	0-18	0-55	0-32	0-28	0-20	
Offset at distance											
	0	±15	±10		±20	±12	±10	±30	±20	±18	±10
	3	±15	±10		±20	±12	±10	±30	±20	±18	±10
	5	±15	±10	±10	±20	±12	±10	±30	±20	±18	±10
	8	±15	±10	±7	±20	±12	±10	±30	±20	±18	±10
	10	±15	±10	±7	±20	±12	±10	±30	±20	±18	±10
	12	±15	±8	±7	±20	±12	±10	±30	±20	±18	±10
	15	±15	±8		±20	±12	±10	±30	±20	±18	±10
	18	±15			±20	±12	±10	±30	±20	±14	
	20	±15			±20	±12		±30	±20	±14	
	24	±15			±20	±10		±30	±20	±12	
	28				±20			±30	±14	±12	
	30				±20			±30	±14		
	32				±20			±30	±14		
	35				±20			±30			
	40							±30			
Dimensions in mm											

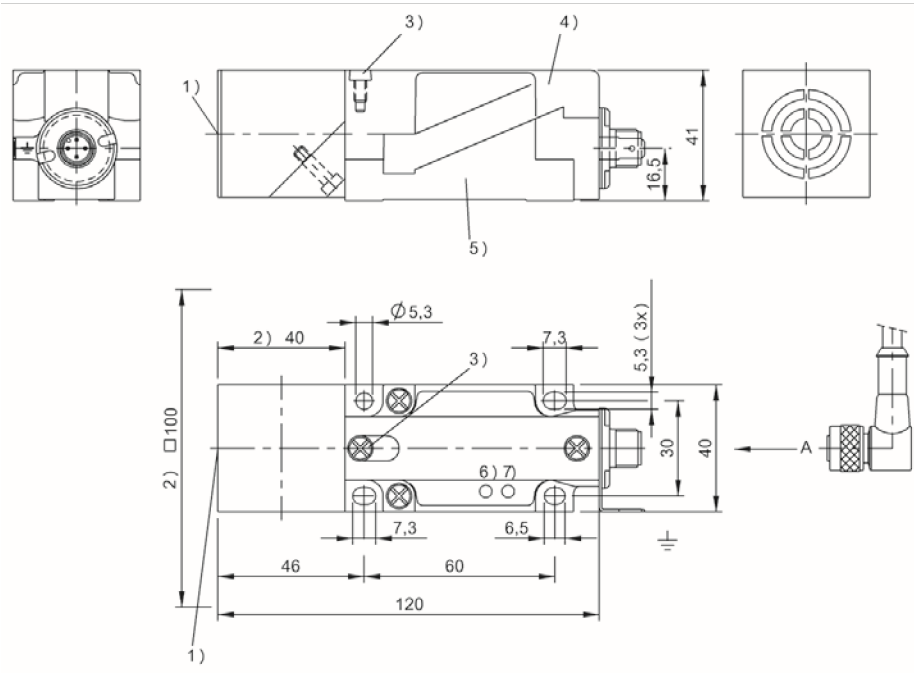

1) Sensing surface, 2) Clear zone, 3) Locking screw, 4) Module unit, 5) Mounting base, 6) Power, 7) Tag present



IO-Link, 10 Bytes process data length	BISO0E0 BIS L-409-045-002-07-S4
Product Group	LF (125 kHz)
Dimension	Ø 18 x 75 mm
Installation	metal-free (clear zone)
Antenna type	round
Connection	Connector, M12x1 connector, 4-pin, 0.50 m, PU
Housing material	Brass, interface PBT
Interface	IO-Link
Operating voltage U_b	18...30 VDC
Ambient temperature	0...70 °C
Protection degree	IP67
Approval/Conformity	CE, UL-FILE E227256, Vol.X1, BIS

Use with **IO-Link master** only

Appropriate data carrier

	BISO03R BISO035	BISO03T BISO038	BISO03W BISO03F
Data carrier distance to metal	metal-free	metal-free	metal-free
Data carrier clear zone			
Working distance for writing			
Working distance for reading	0-23	0-27	0-16
Offset at distance			
	0 ±12	±15	±8
	3 ±12	±15	±8
	7 ±12	±15	±8
	8 ±12	±15	±8
	10 ±12	±15	±8
	12 ±12	±15	±4
	15 ±12	±15	±4
	18	±15	
	20	±15	
	25	±6	
Dimensions in mm			

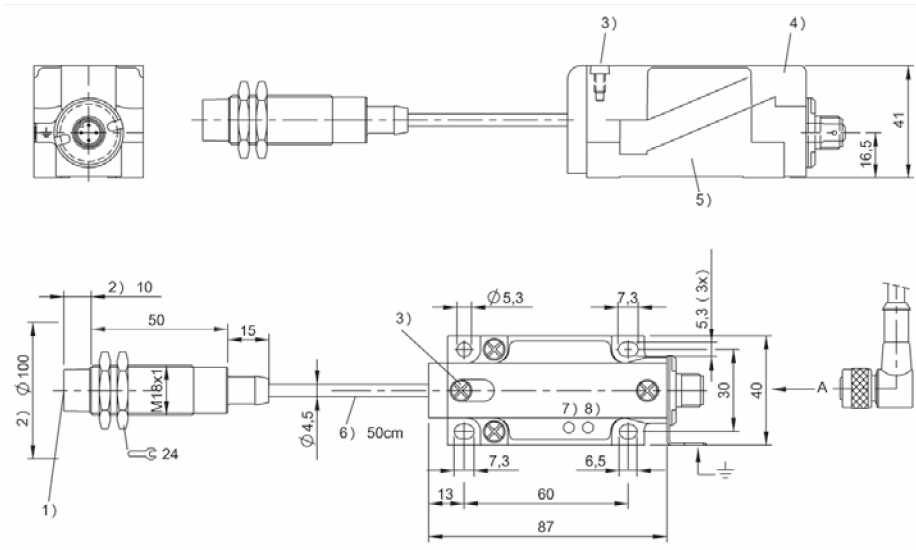

1) Sensing surface, 2) Clear zone, 3) Locking screw, 4) Module unit, 5) Mounting base, 6) Cable length, 7) Power, 8) Tag present



IO-Link, 10 Bytes process data length	BISO0E1 BIS L-409-045-003-07-S4
Product Group	LF (125 kHz)
Dimension	Ø 12 x 53 mm
Installation	metal-free (clear zone)
Antenna type	round
Connection	Connector, M12x1 connector, 4-pin, 0.50 m, PU
Housing material	Brass, interface PBT
Interface	IO-Link
Operating voltage U_b	18...30 VDC
Ambient temperature	0...70 °C
Protection degree	IP67
Approval/Conformity	CE, UL-FILE E227256, Vol.X1, BIS

Use with **IO-Link master** only

Appropriate data carrier

	BISO03W	BISO03F
Data carrier distance to metal	metal-free	
Data carrier clear zone		
Working distance for writing		
Working distance for reading	0-11	
Offset at distance		
	0	±6
	3	±6
	7	±4
	8	±4
	10	±2
Dimensions in mm		

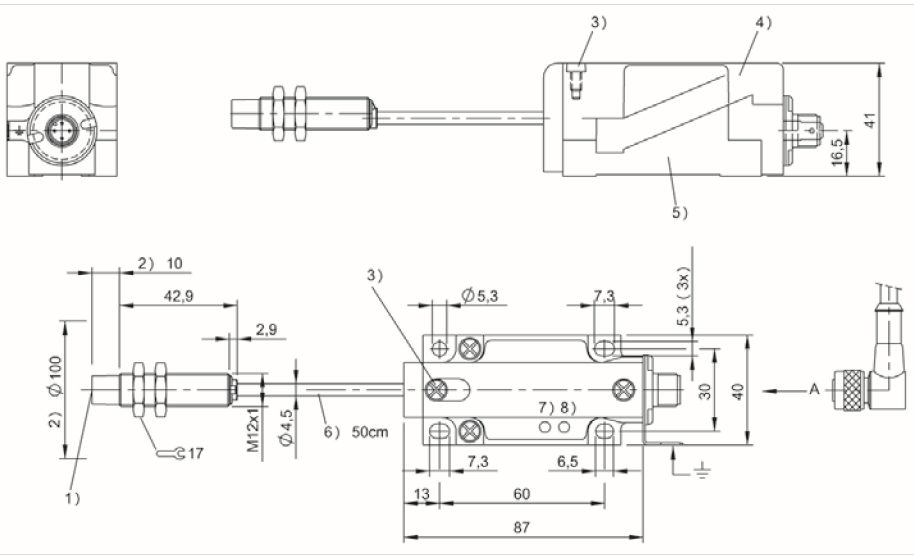

1) Sensing surface, 2) Clear zone, 3) Locking screw, 4) Module unit, 5) Mounting base, 6) Cable length, 7) Power, 8) Tag present



IO-Link, 10 Bytes process data length	BIS00E2 BIS L-409-045-004-07-S4
Product Group	LF (125 kHz)
Dimension	25 x 10 x 50 mm
Installation	metal-free (clear zone)
Antenna type	round
Connection	Connector, M12x1 connector, 4-pin, 0.50 m, PU
Housing material	ABS, interface PBT
Interface	IO-Link
Operating voltage U_b	18...30 VDC
Ambient temperature	0...70 °C
Protection degree	IP67
Approval/Conformity	CE, UL-FILE E227256, Vol.X1, BIS

Use with **IO-Link master** only

Appropriate data carrier

	BIS003R BIS0035	BIS003T BIS0038	BIS003W BIS003F
Data carrier distance to metal	metal-free	metal-free	metal-free
Data carrier clear zone			
Working distance for writing			
Working distance for reading	0-23	0-27	0-16
Offset at distance			
	0 ±12	±15	±8
	3 ±12	±15	±8
	7 ±12	±15	±8
	8 ±12	±15	±8
	10 ±12	±15	±8
	12 ±12	±15	±4
	15 ±12	±15	±4
	18 ±8	±15	
	20 ±8	±15	
	25	±6	
Dimensions in mm			

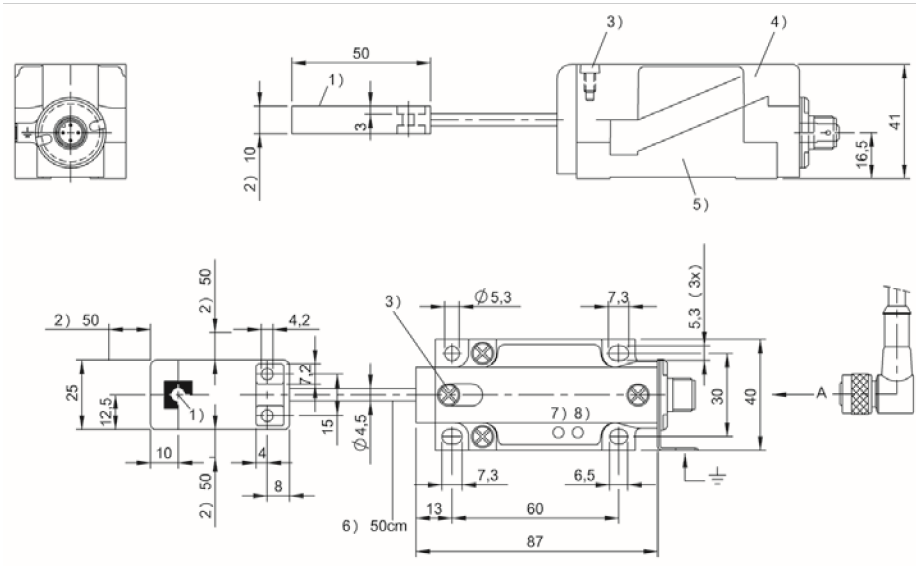

1) Sensing surface, 2) Clear zone, 3) Locking screw, 4) Module unit, 5) Mounting base, 6) Cable length, 7) Power, 8) Tag present



	BIS00CM BIS L-405-033-001-05-MU
Product Group	LF (125 kHz)
Dimension	40 x 41 x 120 mm
Installation	metal-free (clear zone)
Antenna type	round
Connection	—
Housing material	PBT
Interface	parallel
Operating voltage U_b	19.2...26.4 VDC
Ambient temperature	0...70 °C
Protection degree	IP67
Approval/Conformity	CE, UL-FILE E227256, Vol.X1, BIS

Use with **IO-Link master** only

Appropriate data carrier

	BIS003R BIS0035			BIS003T BIS0038			BIS003U BIS003C			BIS003W BIS003F	
	metal-free	on metal	flush in metal	metal-free	on metal	flush in metal	metal-free	on metal	flush in metal	metal-free	
Data carrier distance to metal											
Data carrier clear zone											
Working distance for writing											
Working distance for reading	0-30	0-15	5-12	0-40	0-24	0-18	0-55	0-32	0-28	0-20	
Offset at distance											
	0	±15	±10		±20	±12	±10	±30	±20	±18	±10
	3	±15	±10		±20	±12	±10	±30	±20	±18	±10
	5	±15	±10	±10	±20	±12	±10	±30	±20	±18	±10
	8	±15	±10	±7	±20	±12	±10	±30	±20	±18	±10
	10	±15	±10	±7	±20	±12	±10	±30	±20	±18	±10
	12	±15	±8	±7	±20	±12	±10	±30	±20	±18	±10
	15	±15	±8		±20	±12	±10	±30	±20	±18	±10
	18	±15			±20	±12	±10	±30	±20	±14	
	20	±15			±20	±12		±30	±20	±14	
	24	±15			±20	±10		±30	±20	±12	
	28				±20			±30	±14	±12	
	30				±20			±30	±14		
	32				±20			±30	±14		
	35				±20			±30			
	40							±30			
Dimensions in mm											

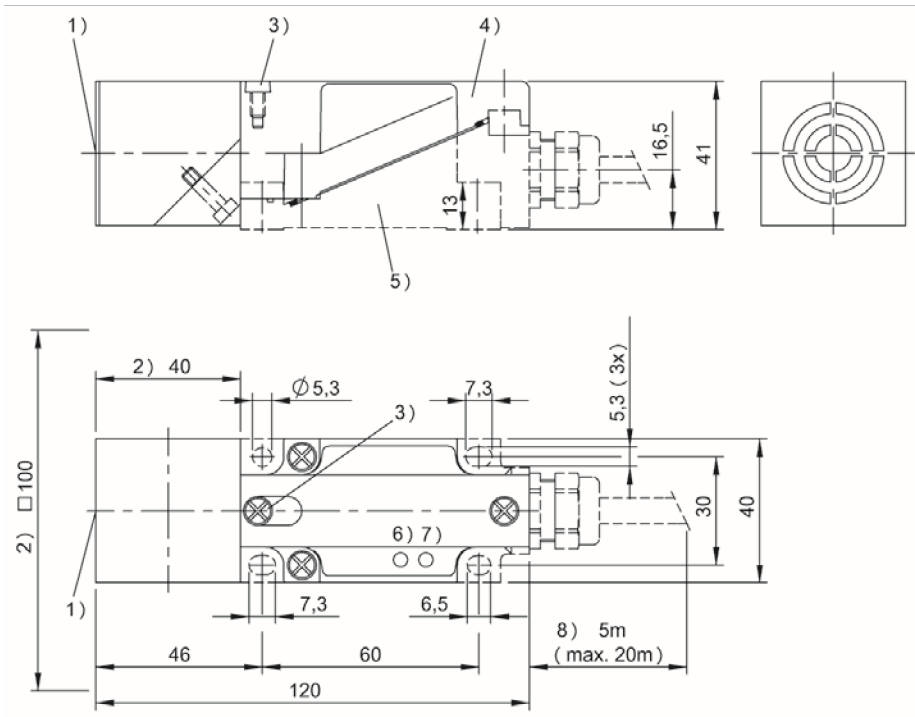

1) Sensing surface, 2) Clear zone, 3) Locking screw, 4) Module unit, 5) Mounting base, 6) Power, 7) Tag present, 8) standard length



	BIS00CT BIS L-405-037-001-05-MU
Product Group	LF (125 kHz)
Dimension	40 x 41 x 120 mm
Installation	metal-free (clear zone)
Antenna type	round
Connection	—
Housing material	PBT
Interface	parallel
Operating voltage U_b	19.2...26.4 VDC
Ambient temperature	0...70 °C
Protection degree	IP67
Approval/Conformity	CE, UL-FILE E227256, Vol.X1, BIS

Appropriate data carrier

	BIS003R BIS0035			BIS003T BIS0038			BIS003U BIS003C			BIS003W BIS003F	
	metal-free	on metal	flush in metal	metal-free	on metal	flush in metal	metal-free	on metal	flush in metal	metal-free	
Data carrier distance to metal											
Data carrier clear zone											
Working distance for writing											
Working distance for reading	0-30	0-15	5-12	0-40	0-24	0-18	0-55	0-32	0-28	0-20	
Offset at distance											
	0	±15	±10		±20	±12	±10	±30	±20	±18	±10
	3	±15	±10		±20	±12	±10	±30	±20	±18	±10
	5	±15	±10	±10	±20	±12	±10	±30	±20	±18	±10
	8	±15	±10	±7	±20	±12	±10	±30	±20	±18	±10
	10	±15	±10	±7	±20	±12	±10	±30	±20	±18	±10
	12	±15	±8	±7	±20	±12	±10	±30	±20	±18	±10
	15	±15	±8		±20	±12	±10	±30	±20	±18	±10
	18	±15			±20	±12	±10	±30	±20	±14	
	20	±15			±20	±12		±30	±20	±14	
	24	±15			±20	±10		±30	±20	±12	
	28				±20			±30	±14	±12	
	30				±20			±30	±14		
	32				±20			±30	±14		
	35				±20			±30			
	40							±30			
Dimensions in mm											

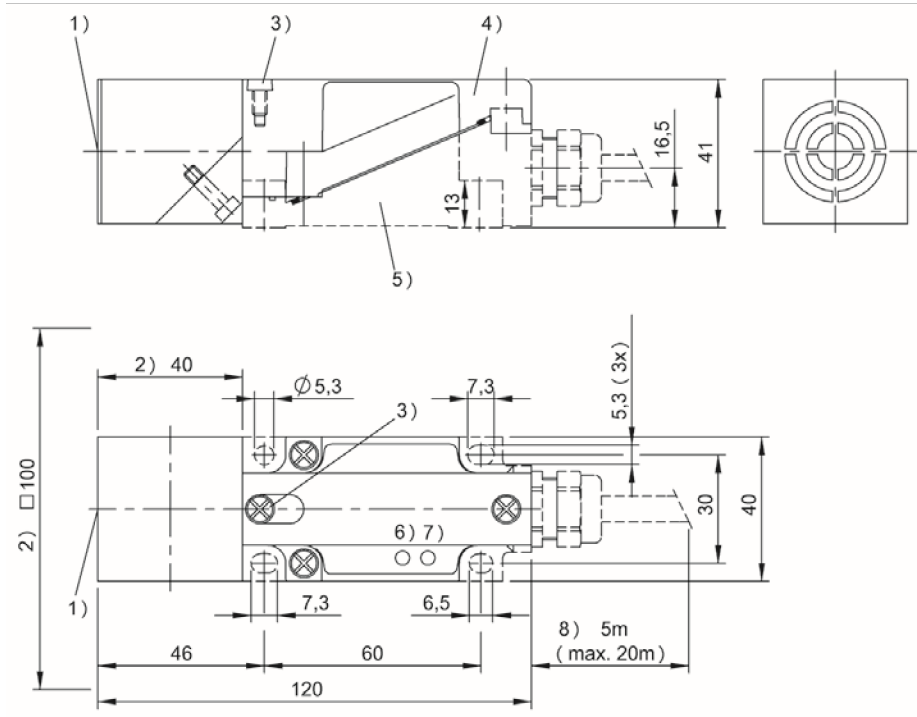

1) Sensing surface, 2) Clear zone, 3) Locking screw, 4) Module unit, 5) Mounting base, 6) Power, 7) Tag present, 8) standard length



	BCC00R2 BIS L-503-PU1-05
Product Group	LF (125 kHz)
Dimension	—
Installation	—
Antenna type	—
Connection	Cable with connector housing, 5.00 m, PU
Housing material	PBT
Interface	parallel
Operating voltage U_b	—
Ambient temperature	—
Protection degree	IP65
Approval/Conformity	CE

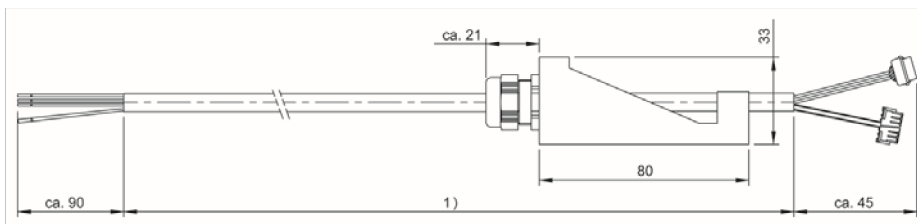

1) Cable length see text



	BCC00R3 BIS L-503-PU1-10
Produktgruppe	LF (125 kHz)
Abmessung	—
Einbau	—
Antennenform	—
Anschluss	Cable with connector housing, 10.00 m, PU
Gehäusematerial	PBT
Schnittstelle	parallel
Betriebsspannung Ub	—
Umgebungstemperatur	—
Schutzart	IP67
Zulassung/Konformität	CE

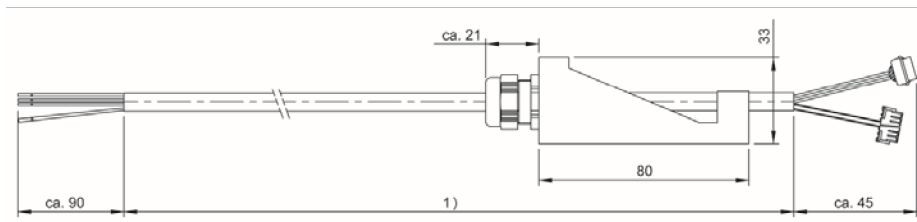

1) Cable length see text



		BCC00R4 BIS L-503-PU1-15
Product Group	LF (125 kHz)	
Dimension	—	
Installation	—	
Antenna type	—	
Connection	Cable with connector housing, 15.00 m, PU	
Housing material	PBT	
Interface	parallel	
Operating voltage U_b	—	
Ambient temperature	—	
Protection degree	IP65	
Approval/Conformity	CE	

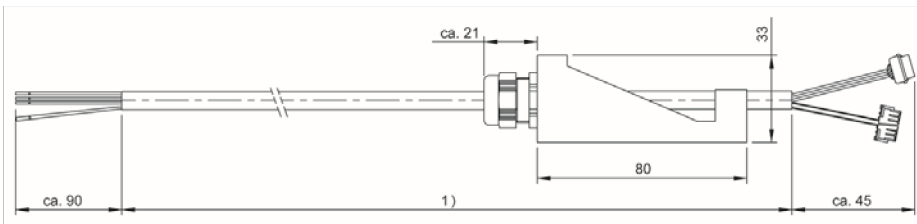

1) Cable length see text



		BCC00R5 BIS L-503-PU1-20
Product Group	LF (125 kHz)	
Dimension	—	
Installation	—	
Antenna type	—	
Connection	Cable with connector housing, 20.00 m, PU	
Housing material	PBT	
Interface	parallel	
Operating voltage U_b	—	
Ambient temperature	—	
Protection degree	IP65	
Approval/Conformity	CE	

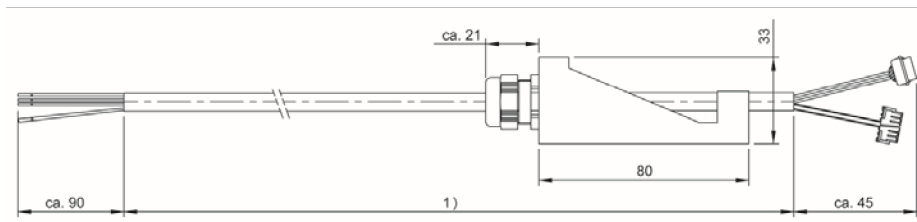

1) Cable length see text



	BIS00CN BIS L-405-033-002-05-MU
Product Group	LF (125 kHz)
Dimension	Ø 18 x 75 mm
Installation	metal-free (clear zone)
Antenna type	round
Connection	0.50 m, PU
Housing material	Brass, interface PBT
Interface	parallel
Operating voltage U_b	19.2...26.4 VDC
Ambient temperature	0...70 °C
Protection degree	IP67
Approval/Conformity	CE, UL-FILE E227256, Vol.X1, BIS

Appropriate data carrier

	BIS003R BIS0035	BIS003T BIS0038	BIS003W BIS003F
Data carrier distance to metal	metal-free	metal-free	metal-free
Data carrier clear zone			
Working distance for writing			
Working distance for reading	0-23	0-27	0-16
Offset at distance			
	0 ±12	±15	±8
	3 ±12	±15	±8
	7 ±12	±15	±8
	8 ±12	±15	±8
	10 ±12	±15	±8
	12 ±12	±15	±4
	15 ±12	±15	±4
	18	±15	
	20	±15	
	25	±6	
Dimensions in mm			

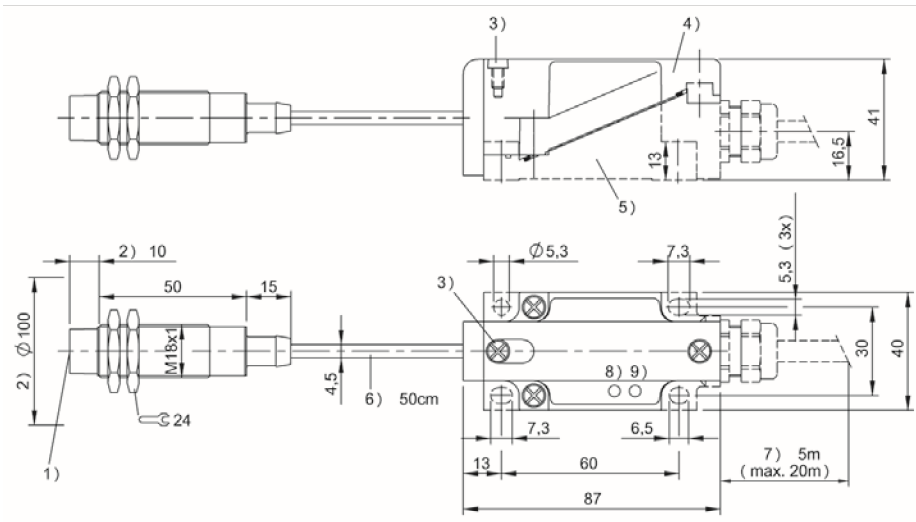

1) Sensing surface, 2) Clear zone, 3) Locking screw, 4) Module unit, 5) Mounting base, 6) Cable length, 7) standard length, 8) Power, 9) Tag present



	BIS00CP BIS L-405-033-003-05-MU
Product Group	LF (125 kHz)
Dimension	Ø 12 x 53 mm
Installation	metal-free (clear zone)
Antenna type	round
Connection	0.50 m, PU
Housing material	Brass, interface PBT
Interface	parallel
Operating voltage U_b	19.2...26.4 VDC
Ambient temperature	0...70 °C
Protection degree	IP67
Approval/Conformity	CE, UL-FILE E227256, Vol.X1, BIS

Appropriate data carrier

	BIS003W	BIS003F
Data carrier distance to metal	metal-free	
Data carrier clear zone		
Working distance for writing		
Working distance for reading	0-11	
Offset at distance		
	0	±6
	3	±6
	7	±4
	8	±4
	10	±2
Dimensions in mm		

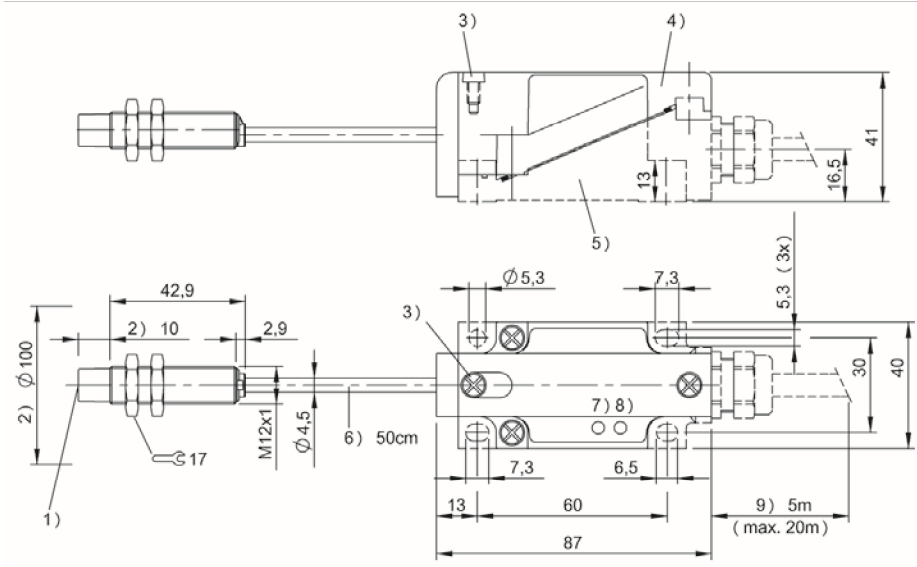

1) Sensing surface, 2) Clear zone, 3) Locking screw, 4) Module unit, 5) Mounting base, 6) Cable length, 7) standard length, 8) Power, 9) Tag present



BIS00CR BIS L-405-033-004-05-MU	
Product Group	LF (125 kHz)
Dimension	25 x 10 x 50 mm
Installation	metal-free (clear zone)
Antenna type	round
Connection	0.50 m, PU
Housing material	ABS, interface PBT
Interface	parallel
Operating voltage U_b	19.2...26.4 VDC
Ambient temperature	0...70 °C
Protection degree	IP67
Approval/Conformity	CE, UL-FILE E227256, Vol.X1, BIS

Appropriate data carrier

	BIS003R BIS0035	BIS003T BIS0038	BIS003W BIS003F
Data carrier distance to metal	metal-free	metal-free	metal-free
Data carrier clear zone			
Working distance for writing			
Working distance for reading	0-23	0-27	0-16
Offset at distance			
	0 ±12	±15	±8
	3 ±12	±15	±8
	7 ±12	±15	±8
	8 ±12	±15	±8
	10 ±12	±15	±8
	12 ±12	±15	±4
	15 ±12	±15	±4
	18 ±8	±15	
	20 ±8	±15	
	25	±6	
Dimensions in mm			

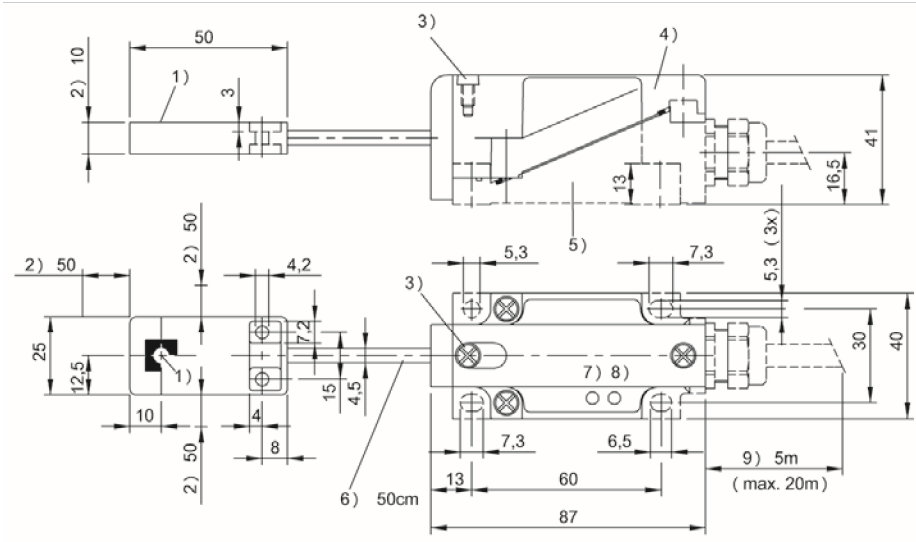

1) Sensing surface, 2) Clear zone, 3) Locking screw, 4) Module unit, 5) Mounting base, 6) Cable length, 7) Power, 8) Tag present, 9) standard length



BIS00CU BIS L-405-037-002-05-MU	
Product Group	LF (125 kHz)
Dimension	Ø 18 x 75 mm
Installation	metal-free (clear zone)
Antenna type	round
Connection	0.50 m, PU
Housing material	Brass, interface PBT
Interface	parallel
Operating voltage U_b	19.2...26.4 VDC
Ambient temperature	0...70 °C
Protection degree	IP67
Approval/Conformity	CE, UL-FILE E227256, Vol.X1, BIS

Appropriate data carrier

	BIS003R BIS0035	BIS003T BIS0038	BIS003W BIS003F
Data carrier distance to metal	metal-free	metal-free	metal-free
Data carrier clear zone			
Working distance for writing			
Working distance for reading	0-23	0-27	0-16
Offset at distance			
	0 ±12	±15	±8
	3 ±12	±15	±8
	7 ±12	±15	±8
	8 ±12	±15	±8
	10 ±12	±15	±8
	12 ±12	±15	±4
	15 ±12	±15	±4
	18	±15	
	20	±15	
	25	±6	
Dimensions in mm			

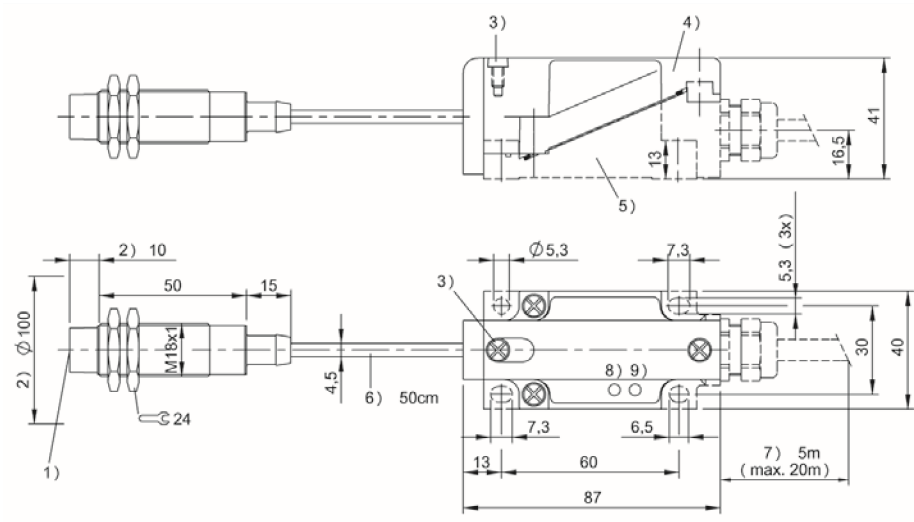

1) Sensing surface, 2) Clear zone, 3) Locking screw, 4) Module unit, 5) Mounting base, 6) Cable length, 7) standard length, 8) Power, 9) Tag present



	BIS00CW BIS L-405-037-003-05-MU
Product Group	LF (125 kHz)
Dimension	Ø 12 x 53 mm
Installation	metal-free (clear zone)
Antenna type	round
Connection	0.50 m, PU
Housing material	Brass, interface PBT
Interface	parallel
Operating voltage U_b	19.2...26.4 VDC
Ambient temperature	0...70 °C
Protection degree	IP67
Approval/Conformity	CE, UL-FILE E227256, Vol.X1, BIS

Appropriate data carrier

	BIS003W	BIS003F
Data carrier distance to metal	metal-free	
Data carrier clear zone		
Working distance for writing		
Working distance for reading	0-11	
Offset at distance		
	0 ±6	
	3 ±6	
	7 ±4	
	8 ±4	
	10 ±2	
Dimensions in mm		

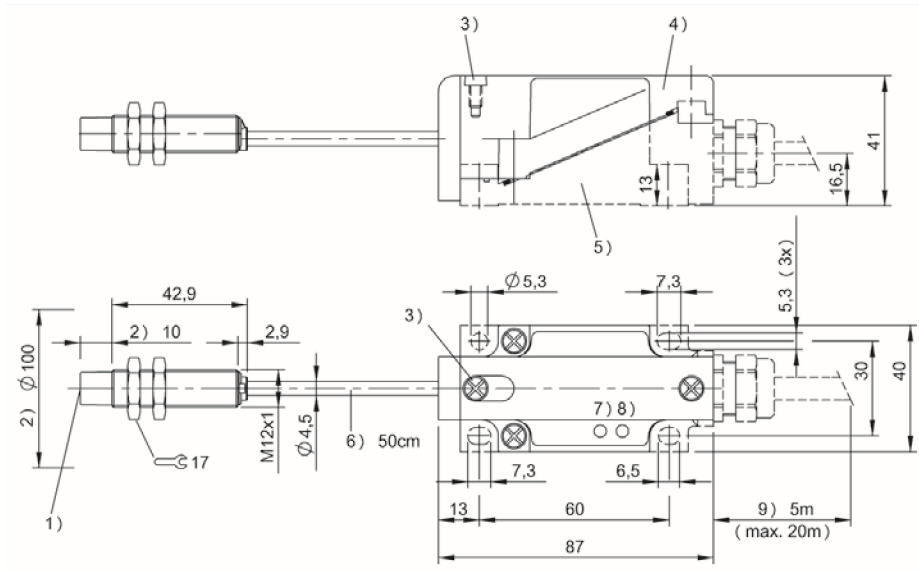

1) Sensing surface, 2) Clear zone, 3) Locking screw, 4) Module unit, 5) Mounting base, 6) Cable length, 7) Power, 8) Tag present, 9) standard length



BIS00CY BIS L-405-037-004-05-MU	
Product Group	LF (125 kHz)
Dimension	25 x 10 x 50 mm
Installation	metal-free (clear zone)
Antenna type	round
Connection	0.50 m, PU
Housing material	ABS, interface PBT
Interface	parallel
Operating voltage U_b	19.2...26.4 VDC
Ambient temperature	0...70 °C
Protection degree	IP67
Approval/Conformity	CE, UL-FILE E227256, Vol.X1, BIS

Appropriate data carrier

	BIS003R BIS0035	BIS003T BIS0038	BIS003W BIS003F
Data carrier distance to metal	metal-free	metal-free	metal-free
Data carrier clear zone			
Working distance for writing			
Working distance for reading	0-23	0-27	0-16
Offset at distance			
	0 ±12	±15	±8
	3 ±12	±15	±8
	7 ±12	±15	±8
	8 ±12	±15	±8
	10 ±12	±15	±8
	12 ±12	±15	±4
	15 ±12	±15	±4
	18 ±8	±15	
	20 ±8	±15	
	25	±6	
Dimensions in mm			

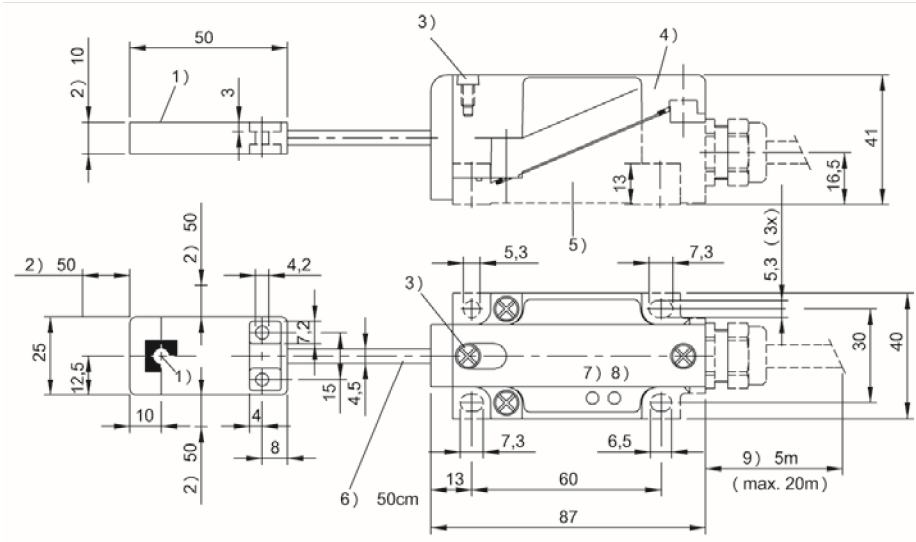

1) Sensing surface, 2) Clear zone, 3) Locking screw, 4) Module unit, 5) Mounting base, 6) Cable length, 7) Power, 8) Tag present, 9) standard length



For processor units BAE003W and BAE003U (Easy Loop)	BISO0CH BIS L-400-043-001-02-S115
Product Group	LF (125 kHz)
Dimension	40 x 41 x 120 mm
Installation	metal-free (clear zone)
Antenna type	round
Connection	Connector, M12x1 connector, 8-pin
Housing material	PBT
Interface	RS422 (Easy Loop)
Operating voltage U_b	19.2...26.4 VDC
Ambient temperature	0...70 °C
Protection degree	IP67
Approval/Conformity	CE, UL-FILE E227256, Vol.X1, BIS

Appropriate data carrier

	BISO03R BISO035			BISO03T BISO038			BISO03U BISO03C			BISO03W BISO03F	
	metal-free	on metal	flush in metal	metal-free	on metal	flush in metal	metal-free	on metal	flush in metal	metal-free	
Data carrier distance to metal											
Data carrier clear zone											
Working distance for writing											
Working distance for reading	0-30	0-15	5-12	0-40	0-24	0-18	0-55	0-32	0-28	0-20	
Offset at distance											
	0	±15	±10		±20	±12	±10	±30	±20	±18	±10
	3	±15	±10		±20	±12	±10	±30	±20	±18	±10
	5	±15	±10	±10	±20	±12	±10	±30	±20	±18	±10
	8	±15	±10	±7	±20	±12	±10	±30	±20	±18	±10
	10	±15	±10	±7	±20	±12	±10	±30	±20	±18	±10
	12	±15	±8	±7	±20	±12	±10	±30	±20	±18	±10
	15	±15	±8		±20	±12	±10	±30	±20	±18	±10
	18	±15			±20	±12	±10	±30	±20	±14	
	20	±15			±20	±12		±30	±20	±14	
	24	±15			±20	±10		±30	±20	±12	
	28				±20			±30	±14	±12	
	30				±20			±30	±14		
	32				±20			±30	±14		
	35				±20			±30			
	40							±30			
Dimensions in mm											

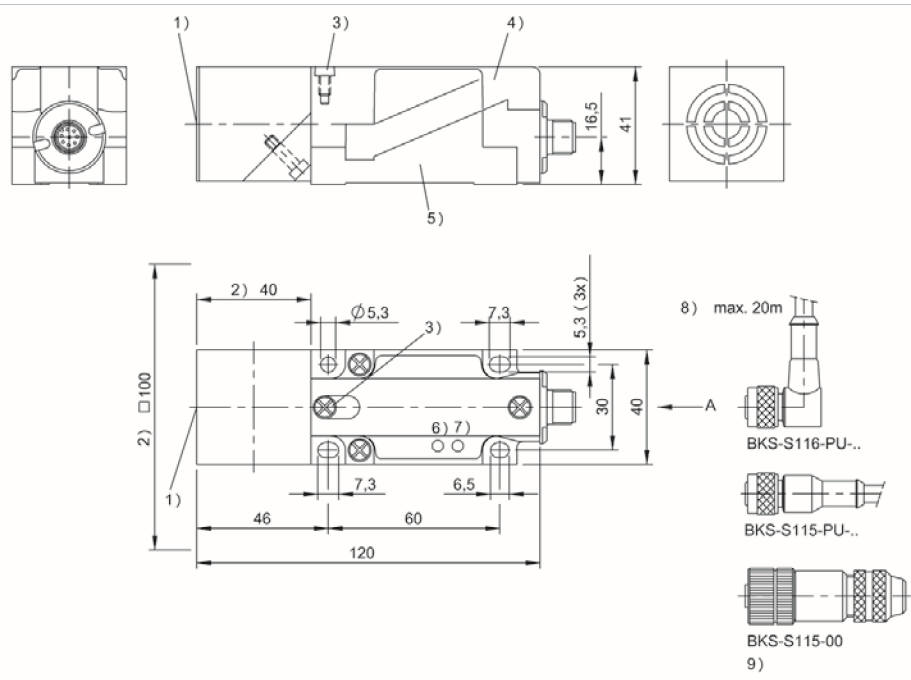

1) Sensing surface, 2) Clear zone, 3) Locking screw, 4) Module unit, 5) Mounting base, 6) Power, 7) Tag present, 8) Cable length, 9) no cable



For processor units BAE003W and BAE003U (Easy Loop)	BISO0C.J BIS L-400-043-002-02-S115
Product Group	LF (125 kHz)
Dimension	Ø 18 x 75 mm
Installation	metal-free (clear zone)
Antenna type	round
Connection	Connector, M12x1 connector, 8-pin, 0.50 m, PU
Housing material	Brass, interface PBT
Interface	RS422 (Easy Loop)
Operating voltage U_b	19.2...26.4 VDC
Ambient temperature	0...70 °C
Protection degree	IP67
Approval/Conformity	CE, UL-FILE E227256, Vol.X1, BIS

Appropriate data carrier

	BISO03R BISO035	BISO03T BISO038	BISO03W BISO03F
Data carrier distance to metal	metal-free	metal-free	metal-free
Data carrier clear zone			
Working distance for writing			
Working distance for reading	0-23	0-27	0-16
Offset at distance			
	0 ±12	±15	±8
	3 ±12	±15	±8
	7 ±12	±15	±8
	8 ±12	±15	±8
	10 ±12	±15	±8
	12 ±12	±15	±4
	15 ±12	±15	±4
	18	±15	
	20	±15	
	25	±6	
Dimensions in mm			

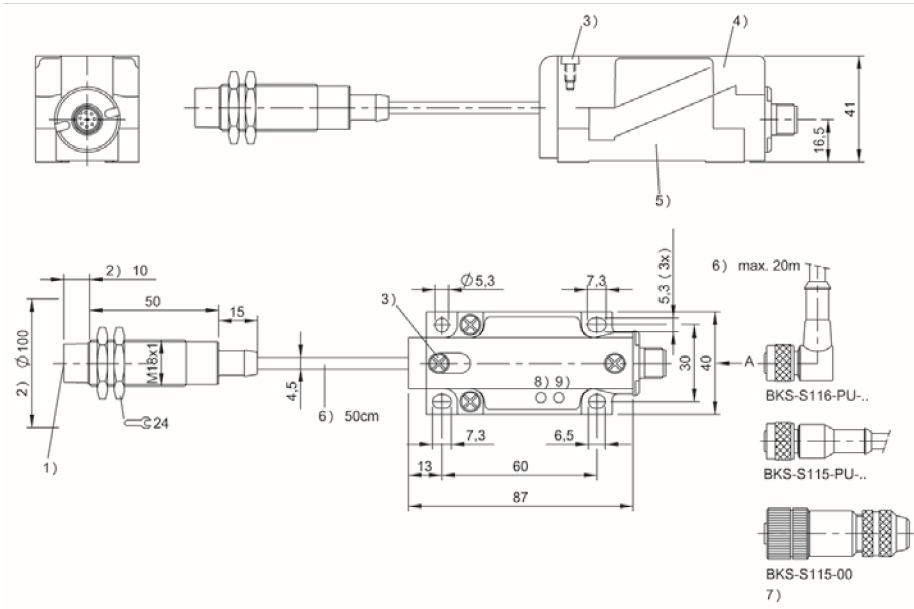

1) Sensing surface, 2) Clear zone, 3) Locking screw, 4) Module unit, 5) Mounting base, 6) Cable length, 7) no cable, 8) Power, 9) Tag present



For processor units BAE003W and BAE003U (Easy Loop)	BISOOCK BIS L-400-043-003-02-S115
Product Group	LF (125 kHz)
Dimension	Ø 12 x 53 mm
Installation	metal-free (clear zone)
Antenna type	round
Connection	Connector, M12x1 connector, 8-pin, 0.50 m, PU
Housing material	Brass, interface PBT
Interface	RS422 (Easy Loop)
Operating voltage U_b	19.2...26.4 VDC
Ambient temperature	0...70 °C
Protection degree	IP67
Approval/Conformity	CE, UL-FILE E227256, Vol.X1, BIS

Appropriate data carrier

	BIS003W	BIS003F
Data carrier distance to metal	metal-free	
Data carrier clear zone		
Working distance for writing		
Working distance for reading	0-11	
Offset at distance		
	0	±6
	3	±6
	7	±4
	8	±4
	10	±2
Dimensions in mm		

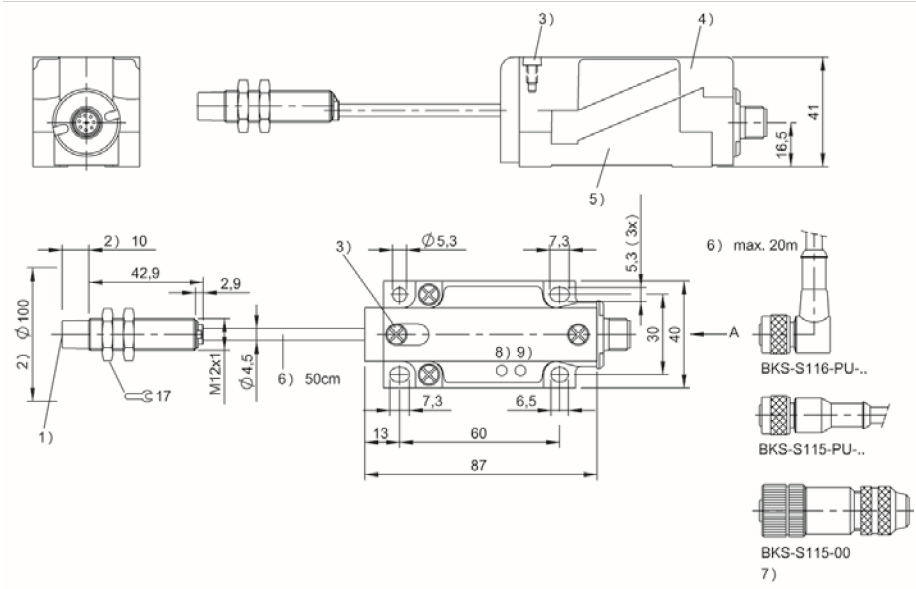

1) Sensing surface, 2) Clear zone, 3) Locking screw, 4) Module unit, 5) Mounting base, 6) Cable length, 7) no cable, 8) Power, 9) Tag present



For processor units BAE003W and BAE003U (Easy Loop)	BIS00CL BIS L-400-043-004-02-S115
Product Group	LF (125 kHz)
Dimension	25 x 10 x 50 mm
Installation	metal-free (clear zone)
Antenna type	round
Connection	Connector, M12x1 connector, 8-pin, 0.50 m, PU
Housing material	ABS, interface PBT
Interface	RS422 (Easy Loop)
Operating voltage U_b	19.2...26.4 VDC
Ambient temperature	0...70 °C
Protection degree	IP67
Approval/Conformity	CE, UL-FILE E227256, Vol.X1, BIS

Appropriate data carrier

	BIS003R BIS0035	BIS003T BIS0038	BIS003W BIS003F
Data carrier distance to metal	metal-free	metal-free	metal-free
Data carrier clear zone			
Working distance for writing			
Working distance for reading	0-23	0-27	0-16
Offset at distance			
	0 ±12	±15	±8
	3 ±12	±15	±8
	7 ±12	±15	±8
	8 ±12	±15	±8
	10 ±12	±15	±8
	12 ±12	±15	±4
	15 ±12	±15	±4
	18 ±8	±15	
	20 ±8	±15	
	25	±6	
Dimensions in mm			

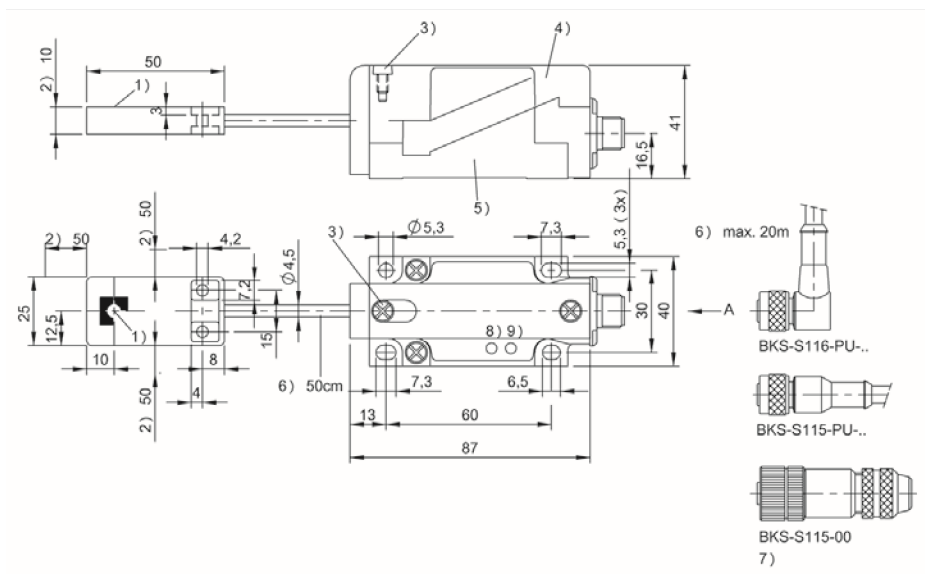

1) Sensing surface, 2) Clear zone, 3) Locking screw, 4) Module unit, 5) Mounting base, 6) Cable length, 7) no cable, 8) Power, 9) Tag present



	BAE00K4 BIS L-870-1-008-X-001	
Product Group	LF (125 kHz)	
Product name	WLAN	
Dimension	100 x 51 x 265 mm	
Antenna type	round	
Use	for data carriers $\varnothing \geq 20$ mm	
Display	TFT Touchscreen-display (color): 480x640 VGA resolution	
Keypad	52 keys, alphanumeric	
Operating voltage U_b	3.7 V DC rechargeable battery pack	
Storage temperature	-40...60 °C	
Ambient temperature	-10...50 °C	
Protection degree	IP65	
Approval/Conformity	CE	
Productview	Page 526	



BAE00EA BIS L-870-1-008-X-004	BAE00EJ BIS L-873-1-008-X-001
LF (125 kHz)	LF (125 kHz)
WLAN + 1D	WLAN
100 x 69 x 265 mm	100 x 51 x 265 mm
round	round
for data carriers $\varnothing \geq 20$ mm	for data carriers $\varnothing < 20$ mm
TFT Touchscreen-display (color): 480x640 VGA resolution	TFT Touchscreen-display (color): 480x640 VGA resolution
52 keys, alphanumeric	52 keys, alphanumeric
3.7 V DC rechargeable battery pack	3.7 V DC rechargeable battery pack
-40...60 °C	-40...60 °C
-10...50 °C	-10...50 °C
IP65	IP65
CE	CE
Page 526	Page 527

526 | RFID | LF (125 kHz)

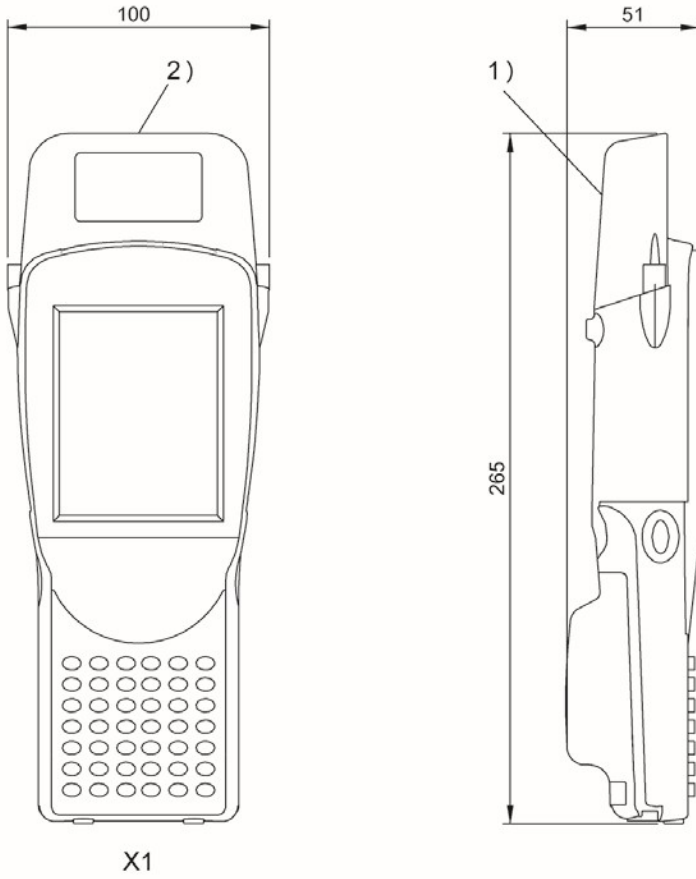

1) Sensing surface, 2) See data for antenna form

BAE00K4

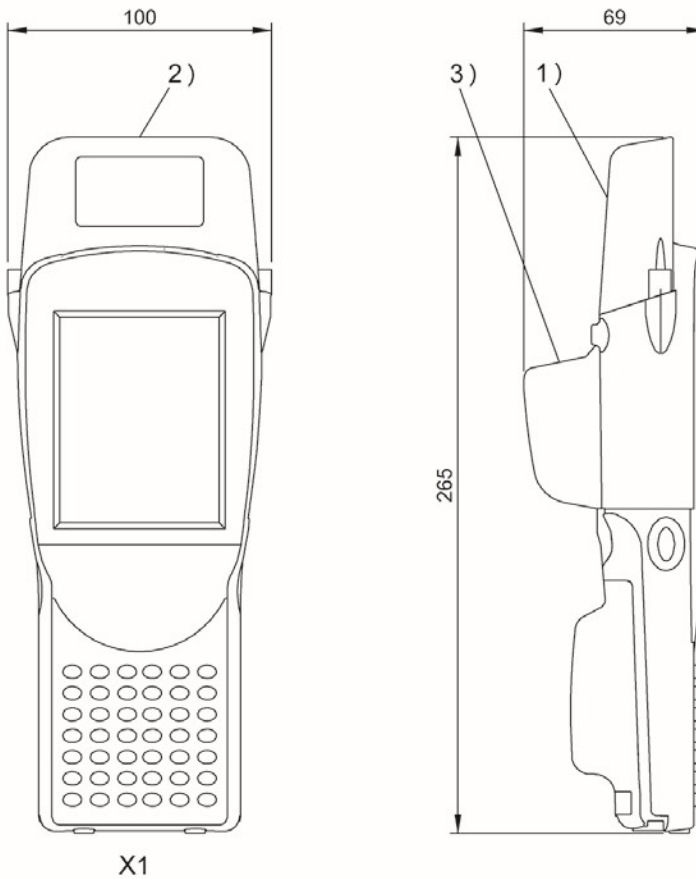

1) Sensing surface, 2) See data for antenna form, 3) Barcode 1D-Scanner

BAE00EA

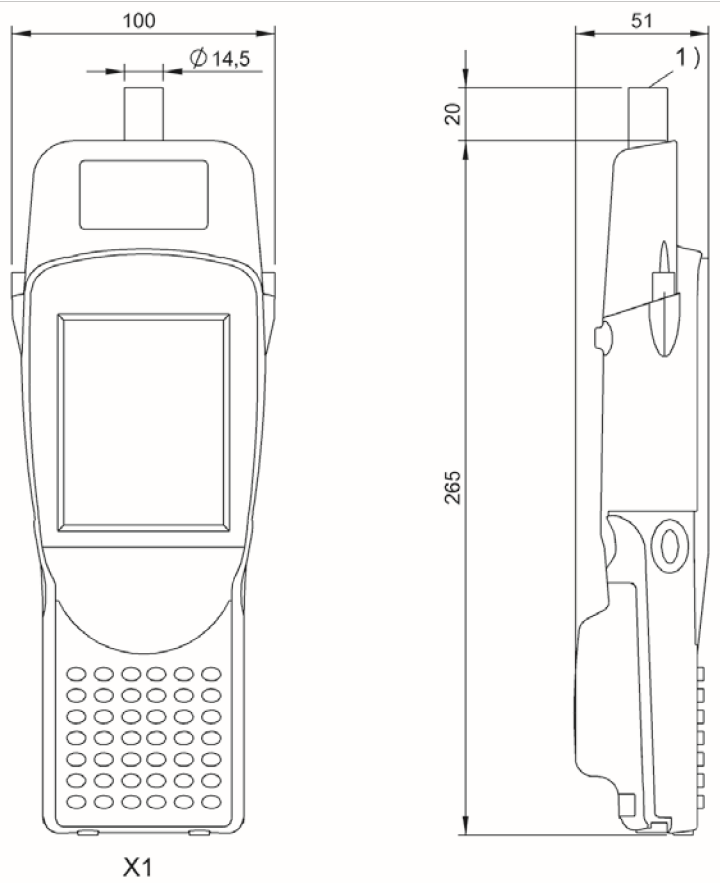

1) Sensing surface, 2) See data for antenna form

BAE00EJ

Sensors

RFID

Machine Vision and
Optical Identification

Human Machine
Interfaces

Systems

Safety

Industrial Networking

Power Supplies

Connectivity

Accessories

RFID

BASICS AND GLOSSARY





ausst. Diese
im Altbereich

Processor unit	Essential component of an RFID system which is used for signal processing and preparation. Usually used or combined with an integrated interface for connecting to the controller/PC system. It is also referred to as a controller.
Autoclave compatible	Capable of being thermally treated in the pressure area of a gas-tight, closable pressure container. The object is to sterilize materials or cure materials in this pressure container, the so-called autoclave, to vulcanize tires and belts and compress fiber composites. Selected data carriers are suitable for use in autoclaves.
BIS C	Balluff RFID product group which describes low frequency (LF) RFID solutions operating at 70/455 kHz. These products are traditionally used for tool identification (Tool-ID).
BIS L/VL	Balluff RFID product group which describes low frequency (LF) RFID solutions operating at 125 kHz. These are suited for simple identification tasks.
BIS M/VM	Balluff RFID product group which describes high frequency (HF) RFID solutions, operating at 13.56 MHz. It supports ISO standards (e.g. DIN ISO 15693, DIN ISO 14443A) and is suitable for a variety of applications.
BIS U/VU	Balluff RFID product group which describes ultra-high frequency (UHF) system solutions operating at 860 to 960 MHz. Especially suited for applications in which long read distances and multi-tagging are required.
BIS V	Designation for a Balluff RFID processor/controller unit. This version supports read heads/antennas from the product families BIS L, BIS C, BIS M, BIS U and IO-Link.
Flush installation	Specification for sensor/read-write head installation to indicate whether the sensor or read/write head may be embedded in metal up to the active surface. This is a function of its design and ensures flawless operation. The switching distance/range is less than for differently constructed sensors/read-write heads of the same size.
Code present	Message indicating that the data carrier is within the detection range of the read/write head. The data can now be read and written.
CRC Check	Cyclic redundancy check. This is a procedure for determining a check value for data in order to detect errors in transmission or saving.
Data bolt	A threaded body with integrated data carrier which is available in various thread sizes, bolt sizes and materials.

Data coupler RFID	Data transmitter which uses induction to send data over a short air gap, thereby eliminating a double mechanical interface.
Data screw	Data carrier which is integrated into a threaded body. The threaded body is available in various thread sizes, screw sizes and materials. Also referred to as databolt.
Data carrier	Electronic data storage device as part of an RFID system for data of any kind. Can be read or programmed by computers, peripherals or automation equipment. Also referred to as a tag. For use in industrial applications there are data carriers in various forms (round, rectangular, special form factors), made of various materials and with different antenna technologies.
Data carrier chip	Memory chip in a data carrier which defines the memory capacity and memory structure.
DIN ISO 14443	International series of standards for non-contact chip cards. These are used in identification systems and access control, but also for payment applications such as credit cards, public transportation tickets etc. Operates at a frequency of 13.56 MHz.
DIN ISO 15693	International series of standards for non-contact chip cards, access control and payment applications. Operates at a frequency of 13.56 MHz and is the prevailing standard in automation.
Adapter ring	Mechanical spacer inserted between the image sensor and lens so that the flange focal distance and thereby the minimum and maximum working distance and the focus range are changed. By this means a standard lens can be used to achieve higher magnifications.
Docking station	Device for connecting portable devices such as an RFID handheld device to a fixed power source. Also called a docking station.
Dynamic read mode	Operating mode of an RFID solution: The processor unit accepts the read/write request from the control system and stores the information regardless of whether there is a data carrier in the active range of the read/write head. As soon as a data carrier enters the active range of the read/write head, the job is executed. This is also known simply as dynamic mode.
Easy loop ID	BIS L system approach with the ability to connect up to 16 read heads to a higher level system through a single processor unit.
Easy Tool-ID	Workaround for machine tools that do not have an integrated tool ID function. Consists of a tool stand with integrated read/write head, a processor unit, a microcontroller and the power supply.

E-Kanban	A system which uses various technologies for controlling the use of components and materials in the manufacturing process. In the electronic version, so-called E-Kanban, RFID data carriers and barcodes replace conventional kanban instruments such as cards. The result is a faster information flow.
Ferrite antenna	Rod shaped inductive antenna for receiving RFID signals. It is built into the data carrier as well as the read/write head and has a polarizing and directional characteristic. When the end of a ferrite bar is pointed at the transmitter, the receiving field strength and thereby the read distance between data carrier and read/write head is reduced. The data carrier and read/write head must therefore be calibrated to each other.
Clear zone (RFID)	Area within which a data carrier is mounted in metallic surroundings to achieve a prescribed read/write distance.
Mounting bracket	Mechanical accessory for mounting read/write heads, data couplers and processor units. May include clamps, mounting plates, mounting bases.
Handheld RFID reader/writer Handheld programmer, Handy programmer	Device for portable writing and reading data carriers. Available for the various technologies LF (low frequency), HF (high frequency), UHF (ultra-high frequency). Ideal for use in harsh environments. Data is transmitted over optional WLAN, Bluetooth or a wired USB connection.
HF	High frequency of 13.56 MHz. Especially suited for use of RFID technology at close range up to 400 mm. The energy transmission of this high-frequency identification system is by means of a magnetic field using inductive coupling.
High memory	Data carriers with a memory capacity > 8K. The performance specifications from applications in automation also require high speed data transmission. Both can be achieved using selected components.
High-speed data carrier	RFID memory which was developed for applications in which it must provide the data to the controller system time-optimized. In combination with the associated read heads two to three times the read speed can be achieved compared with applications compliant with the DIN ISO 15693 standard.
High-temperature tag	RFID data carrier for temperature-resistant use in industrial environments at temperatures up to 220 °C (storage temperature).
High-temperature data carrier	RFID data carrier for temperature-resistant use in industrial environments at temperatures up to 220 °C (storage temperature).
Hollow taper shank (HSK)	Tool holder used in machine tools. Integration into the tool is extremely simple thanks to the standardized size for installation in hollow shank tapers HSK in accordance with DIN 68871-A and steep tapers SK in accordance with ISO/DIS 12164-1.

HSK	Switching hysteresis when target is backed off
Adhesive label	Self-adhesive RFID data carrier
Clamp	Mechanical accessory for mounting read/write heads, data couplers and processor units. Includes mounting brackets, mounting plates, and mounting bases.
Configuration file (GSD, GSDML, EDS, ...)	File (driver file) for incorporating fieldbus components into the controller. The file contains the fieldbus-specific settings.
Charger, charging cradle	Accessory for the handheld programmer, the handy programmer, and the handheld device.
Read head	The part of an RFID system that supplies the data carrier with power and reads the data stored on it. The read head then passes the data to a processor unit which further processes the data.
LF	Low frequency (70 kHz or 125 KHz). The power in LF identification systems is transmitted via a magnetic field by means of inductive coupling. Appropriate for use in difficult conditions such as metal surroundings.
Air interface	Air gap between the data carrier and (read/)write head through which the data and energy are transmitted.
Metal-free installation	Installation/mounting specification, generally defines an installation situation needed for proper function without the use of metallic materials in order to achieve defined data sheet values.
Mifare	World's most often used contactless chip card technology. Complies with ISO-Standards ISO 7816 and ISO 14443A.
Mold ID	System solution for automated managing of injection molding tools in the plastics industry.
Mounting bracket/base/plate	Mechanical accessory for mounting read/write heads, data couplers and processor units. Examples are clamping holders or mounting brackets.
NFC	Near field communication: An international transmission standard based on RFID for contactless exchange of data using electromagnetic induction and loosely coupled coils over short distances of a few centimeters and a data transfer rate of maximum 424 kBit/s.

Non-flush mounting	Specification for installing sensors or read/write heads which do not have a metal housing surrounding their sensing face. These can be recognized by their "caps". This design ensure flawless sensor function. The switching distance/range and permissible offset are greater than for flush mount sensors or read/write heads of the same size.																									
Pistol grip	Accessory for the handheld programmer, the handy programmer, and the handheld device.																									
Process data buffer	In processor units connecting multiple read/write heads the process data buffer is divided into read/write head-specific areas. Process data is the data which is obtained from a technical process by means of a read/write head. The process data represents the current status.																									
Checksum	Information written to the data carrier as 2 bytes. 2 bytes per block are lost. A detailed listing is contained in the manual for the processor unit.																									
RFID	Radio frequency identification: Communication technology for non-contact and automatic identification of objects (including merchandise, goods, people, animals using radio waves).																									
Reader chip	Memory chip in a data carrier which defines the memory capacity and memory structure.																									
RFID data carriers	Electronic data storage medium as part of an RFID system. It can be read and, in specific configurations, also written. Also called a transponder.																									
	<table border="1"> <thead> <tr> <th>Switching distance</th> <th>Size</th> <th>Switching distance</th> </tr> </thead> <tbody> <tr> <td>Standard-switching distance according to EN 60947-5-2</td> <td></td> <td></td> </tr> <tr> <td rowspan="3">2x switching distance compared to standard</td> <td>Ø 3 mm*</td> <td>1 mm flush</td> </tr> <tr> <td>Ø 4 mm/M5*</td> <td>1.5 mm flush</td> </tr> <tr> <td>Ø 6.5 mm...M30</td> <td>1.5...2-x</td> </tr> <tr> <td rowspan="4">3x switching distance compared to standard</td> <td>Ø 3 mm*</td> <td>3 mm non-flush</td> </tr> <tr> <td>Ø 4 mm/M5*</td> <td>5 mm non-flush</td> </tr> <tr> <td>Ø 6.5 mm...M12</td> <td>2.2...3-x</td> </tr> <tr> <td>M18...M30</td> <td>depending on version</td> </tr> <tr> <td>4x switching distance compared to standard</td> <td></td> <td></td> </tr> </tbody> </table>	Switching distance	Size	Switching distance	Standard-switching distance according to EN 60947-5-2			2x switching distance compared to standard	Ø 3 mm*	1 mm flush	Ø 4 mm/M5*	1.5 mm flush	Ø 6.5 mm...M30	1.5...2-x	3x switching distance compared to standard	Ø 3 mm*	3 mm non-flush	Ø 4 mm/M5*	5 mm non-flush	Ø 6.5 mm...M12	2.2...3-x	M18...M30	depending on version	4x switching distance compared to standard		
Switching distance	Size	Switching distance																								
Standard-switching distance according to EN 60947-5-2																										
2x switching distance compared to standard	Ø 3 mm*	1 mm flush																								
	Ø 4 mm/M5*	1.5 mm flush																								
	Ø 6.5 mm...M30	1.5...2-x																								
3x switching distance compared to standard	Ø 3 mm*	3 mm non-flush																								
	Ø 4 mm/M5*	5 mm non-flush																								
	Ø 6.5 mm...M12	2.2...3-x																								
	M18...M30	depending on version																								
4x switching distance compared to standard																										
	*Information for switching distance in mm. The switching distances of these sensors are not standardized.																									
Round antenna	Device for receiving RFID signals. In contrast to the bar/ferrite antenna it has no polarizing or directional effect. The electrostatic lobe is distributed evenly around the antenna. The round antenna is used both in data carriers and in the read/write head. Therefore these need to be tuned to each other.																									
Read/write head	Part of an RFID system that supplies the data carrier with power and reads the data stored on it and stores new data. The read head then passes the data to a processor unit which further processes the data.																									

Read/write time data carrier	Time a data carrier requires for detecting/transmitting data. Comprised of: Data carrier detection + read/write time of the data blocks taken together. The read/write time varies with the data carrier type (FRAM, EEPROM) and the transmission standard.
Service interface	Connection point for various devices. For service purposes it sends device-specific setting data and is not suitable or standardized as a process interface.
Simultaneous operation	Multiple read/write heads are read by a processor unit (controller) simultaneously.
SK	International abbreviation for taper shank, a standardized tool holder in the main spindle of a machine tool. It is used for fast attachment and precise holding of the tool.
Slow tag detection	Data carrier detection whereby the antenna on the read/write head is switched on for detection only every 200 ms.
Rod antenna	Rod shaped inductive antenna for receiving RFID signals (ferrite antenna). It is built into the data carrier as well as the read/write head and has a polarizing and directional characteristic. When the end of a ferrite bar is pointed at the transmitter, the receiving field strength and thereby the read distance between data carrier and read/write head is reduced. The data carrier and read/write head must therefore be calibrated to each other
Static read mode	Mode of operation of an RFID system. The data carrier remains in place in front of the read/write head. This enables a greater read/write distance than in dynamic mode.
Taper	Standardized form of a tool holder for clamping various tools in the main spindle of a machine tool. The taper is standardized in DIN ISO 7388 Part 1. The main field of application is in milling machines.
Subnet 16	Special solution approach for systematic wiring and for operating multiple read/write heads with a gateway component.
Tag	Electronic data storage device used as part of an RFID system for data of any kind. Can be read or programmed by computers, peripherals or automation equipment. For use in industrial applications there are data carriers in various forms (round, rectangular, special form factors), made of various materials and with different antenna technologies. Also referred to as a data carrier.
Tool ID	Identification of tools and tool data for automated detection, traceability of tool data in the area of machine tools. Data carriers and read/write heads are generally installed in metallic surroundings. The requirements for read distance and installation conditions are generally high.

UID	Unique identifier for RFID data carriers. Each number is assigned only once.
UHF	Ultra high frequency (865 to 960 MHz). The power transmission in UHF identification systems takes place by means of electromagnetic waves as in the classic radio systems. Appropriate for use over larger distances (several meters).
Offset	Positioning tolerance between the read/write head and the data carrier
Workpiece identification	Identification of workpieces, semi- and finished products or workpiece carriers. The requirements vary depending on the materials used. Compared with tool identification the requirements for read distance are generally low to moderate. "Dynamic reading" operating mode is often used.
Tool identification	Identification of tools and tool data for automated detection, traceability of tool data in the area of machine tools. Data carriers and read/write heads are generally installed in metallic surroundings. The requirements for read distance and installation conditions are generally high.

RFID SYSTEMS HF (13.56 MHz) BIS M
 RFID SYSTEMS LF (70/455 kHz) BIS C
 RFID SYSTEMS LF (125 kHz) BIS L

Mounting

Flush in steel

The sensing surface can be mounted on the surface of steel so that it is even with adjacent areas.

Non-flush on steel

The sensing surface must not be in contact or surrounded by steel.

Non-metal

The entire clear zone must remain free of any type of metal.

Mounting in steel

To reach the specified read/write distance, the data carrier in the metallic environment must be mounted within a certain metal-free clear zone.

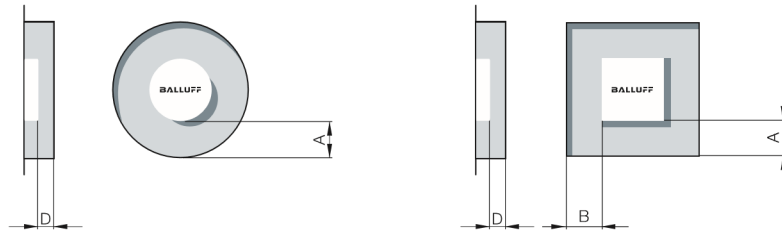

Round data carriers

Block-style data carriers

For further information see data sheets of read/write heads on www.balluff.com

Spatial arrangement of read/write head or read head and data carrier

The key to reliable data exchange between the read/write head or read head and the data carrier is maintaining sufficient dwell time of the data carrier within a specified spatial distance from the read/write head or read head.

For a static read/write or read operation, the data carrier comes to a complete stop in front of the read/write or read head; This enables a larger distance between the two.

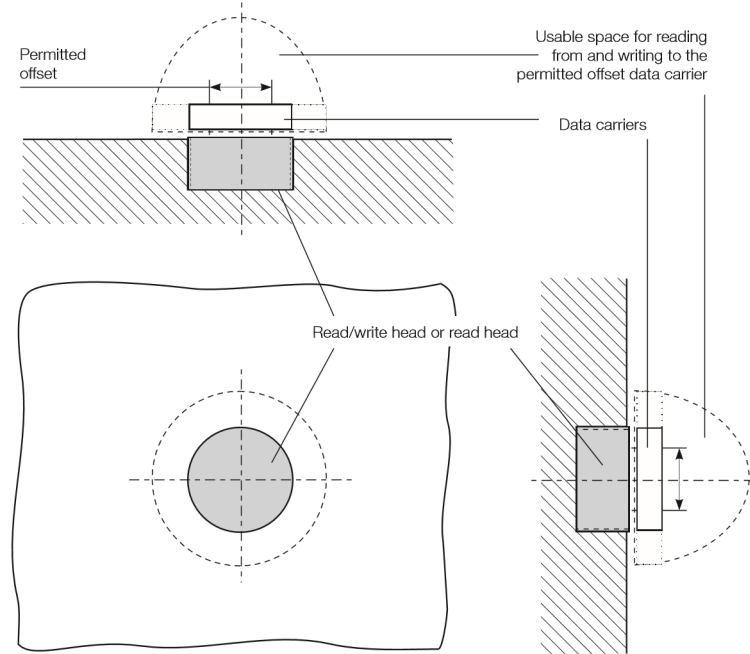

Spatial arrangement of read/write heads or read head and data carrier for non-directional read/write heads or read heads and non-flush mounting (round antenna).

For dynamic operation the data carrier is read or programmed on the fly as it moves past the read/write head or read head. The shorter distance is necessary in order to achieve as large a read/write path or read path as possible. Each read/write head or read head has certain data carriers which can be used with it (the pairing is based on physical size and antenna field configuration).

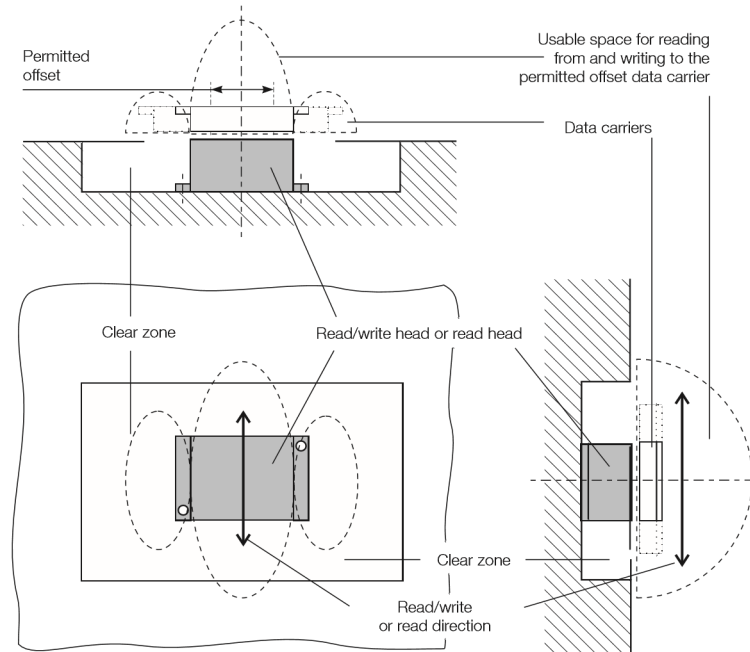

Spatial arrangement of read/write heads or read head and data carrier for directional read/write heads or read heads and non-flush mounting (rod antenna).

RFID SYSTEMS HF (13.56 MHz) BIS M

Read times BIS M-1xx-0x
and BIS M-1xx-20

EEPROM – data carrier with 16 byte blocks		FRAM – data carrier with 16 byte blocks	
Bytes	Read time	Bytes	Read time
0 to 15	20 ms	0 to 15	30 ms
For each additional started 16 bytes add additional	10 ms	For each additional started 16 bytes add additional	15 ms

Read times for BIS M-1xx-1x
and BIS VM-3xx-401-S4

FRAM – data carrier with 64 byte blocks	
Bytes	Read time
0 to 63	14 ms
For each additional started 64 bytes add additional	6 ms

Write times BIS M-1xx-0x
and BIS M-1xx-20

EEPROM – data carrier with 16 byte blocks		FRAM – data carrier with 16 byte blocks	
Bytes	Read time	Bytes	Read time
0 to 15	40 ms	0 to 15	60 ms
For each additional started 16 bytes add additional	30 ms	For each additional started 16 bytes add additional	40 ms

Write times for BIS M-1xx-1x
and BIS VM-3xx-401-S4

FRAM – data carrier with 64 byte blocks	
Bytes	Read time
0 to 63	30 ms
For each additional started 64 bytes add additional	15 ms

Write/read cycles

Data carriers	Memory type	Write cycles	Read cycles	Data retention time
112 bytes	EEPROM	100000	Unlimited	10 years
160 bytes	EEPROM	100000	Unlimited	10 years
736 bytes	EEPROM	100000	Unlimited	10 years
752 bytes	EEPROM	100000	Unlimited	10 years
992 bytes	EEPROM	100000	Unlimited	10 years
2,000 bytes	FRAM	Unlimited	Unlimited	10 years
8,192 bytes	FRAM	Unlimited	Unlimited	10 years
32,768 bytes	FRAM	Unlimited	Unlimited	10 years
65,536 bytes	FRAM	Unlimited	Unlimited	10 years
131,072 bytes	FRAM	Unlimited	Unlimited	10 years

Minimum distance between two data carriers

	BIS M-122-01/L, BIS M-122-02/L	BIS M-110-02/L	BIS M-101-01/A, BIS M-111-02/A	BIS M-102-01/L, BIS M-112-02/L	BIS M-105-01/A, BIS M-105-02/A	BIS M-108-02/A	BIS M-120-01/L	BIS M-151-02/A, BIS M-150-02/A
BIS M-300		>100	>100	>150	>100	>100		
BIS M-301		>200	>200	>200	>100	>200	>250	
BIS M-302, BIS VM-307	>100	>100	>100	>100	>100	>100		
BIS M-304	>100	>100	>100	>100	>100	>100		
BIS M-400-007-001-00-S115		>100	>100	>150	>100	>100		
BIS M-401-007-001-00-S115		>200	>200	>200	>100	>200	>250	
BIS M-400-007-002-00-S115	>100	>100	>100	>100	>100	>100		
BIS M-351, BIS VM-351								>250
BIS M-451-007-001-00-S115								>250

Dimensions in mm

Minimum distance between two read/write heads

BIS M-300	200
BIS M-301	600
BIS M-351/BIS VM-351	600
BIS M-302/BIS VM-307	100
BIS M-304	100
BIS M-400-007-001-00-S115	200
BIS M-401-007-001-00-S115	600
BIS M-451-007-001-00-S115	600
BIS M-400-007-002-00-S115	100
BIS M-410-007-002-00-S115	200
BIS M-411-007-002-00-S115	300
BIS VM-305-001-S4	100
BIS VM-341-401-S4	600
BIS VM-343-401-S4	50
BIS VM-344-401-S4	200
BIS VM-345-401-S4	200
BIS VM-346-401-S4	50
BIS VM-348-401-S4	50
BIS VM-352-001-S4	100
BIS VM-355-401-S4	200

Dimensions in mm

Installation in aluminum

With clear zone, static operation

When installing components in aluminum, provide clear zones for trouble-free operation. In static operation, the depth of the clear zone in aluminum of at least 10 mm must be observed, Figure 1. Clear zone dimension A corresponds to the diameter of the larger communication partner (data carrier or read/write head) plus the maximum possible offset (see information for read/write head), Figure 2. In combination with the read/write heads BIS C-318, 327, 328, 350, 351 and 355, dimension B and C is calculated over the length and width of the larger communication partner (data carrier or read/write head) plus the maximum possible offset (see information for read/write head), Figure 3.

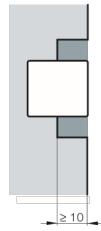

Fig. 1

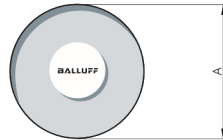

Fig. 2

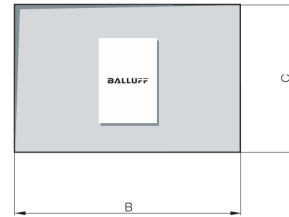

Fig. 3

With clear zone, dynamic operation

In dynamic operation, the depth of the clear zone in aluminum also has to be at least 10 mm, Figure 1. Clear zone dimension A corresponds to twice the diameter of the larger communication partner and the equivalent of the diameter of the smaller communication partner. Clear zone dimension C corresponds to the diameter of the larger communication partner plus the corresponding maximum offset (see information for read/write head), Figure 4. In combination with the read/write heads BIS C-318, 327, 328, 350, 351 and 355, dimension B is calculated from twice the read/write distance (see information about read/write heads) plus the width of the data carrier. Clear zone dimension C corresponds to the read/write head length plus the corresponding maximum offset (see specification for read/write head), Figure 5.

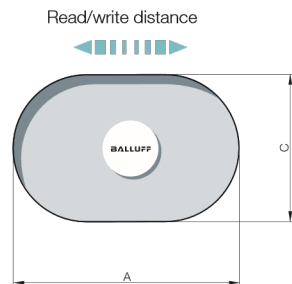

Fig. 4

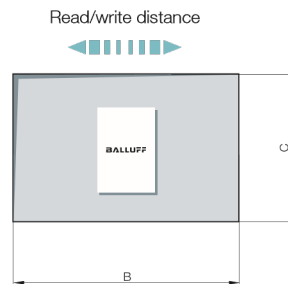

Fig. 5

Read/write cycles

Data carriers	Memory type	Coding	Write cycles up to 30 °C	Write cycles up to 70 °C	Read cycles	Memory organization
511 bytes	EEPROM	-04	1000000	500000	Unlimited	32-byte blocks
1023 bytes	EEPROM	-05	1000000	500000	Unlimited	32-byte blocks
2047 bytes	EEPROM	-11	1000000	500000	Unlimited	64-byte blocks
8 kbytes	FRAM	-32	Unlimited	Unlimited	Unlimited	64-byte blocks

Read times in static mode

For double read and compare:

Data carrier with 32 bytes per block		Data carrier with 64 bytes per block	
Bytes	Read time	Bytes	Read time
From 0 to 31	110 ms	From 0 to 63	220 ms
For each additional started 32 bytes add additional	120 ms	For each additional started 64 bytes add additional	230 ms
From 0 to 255	= 950 ms	From 0 to 2047	= 7350 ms

Write times in static mode

Includes checking and comparing:

Data carrier with 32 bytes per block		Data carrier with 64 bytes per block	
Bytes	Write time [ms]	Bytes	Write time [ms]
From 0 up to 31	110 + n × 10	From 0 up to 63	220 + n × 10
≥ 32	y × 120 + n × 10		y × 230 + n × 10
From 0 up to 255	= max. 3510	From 0 up to 2047	= max. 27830

n = Number of contiguous bytes to write

y = Number of blocks to process

Read times in dynamic operation

Read times within the 1st block for double read and compare:

Data carrier with 32 bytes per block		Data carrier with 64 bytes per block	
Bytes	Read time	Bytes	Read time
From 0 up to 3	14 ms	From 0 up to 3	14 ms
For all additional bytes	3.5 ms	For all additional bytes	3.5 ms
From 0 up to 31	112 ms	From 0 up to 64	224 ms

The times indicated apply after the data carrier has been detected. If the tag has not been recognized, an additional 30 ms must be added to allow for creating the energy field necessary to recognize the data carrier.

Memory organization

Memory size up to 1023 bytes = 32 bytes per block

Memory size 2047 bytes and larger = 64 bytes per block

Maximum speed

To calculate the permitted speed in which the data carrier and head move relative to each other, the static distance values are used. The permissible speed is:

$$V_{\text{max.perm.}} = \frac{\text{Path}}{\text{Time}} = \frac{2 \times |\text{offset value}|}{\text{Processing time}}$$

The offset value is dependent on the read/write distance actually used in the system.

$$\text{Processing time} = \text{Data carrier response time} + \text{Read/write time of first block to be read} + n^1 \times \text{Read/write time for additional started blocks}$$

n¹ = number of started blocks

Installation in taper SK

Data Carriers	BIS C-122			BIS C-103			BIS C-105		
Taper DIN 69871-A	D ^{H11}	t ±0.15	rpm _{max}	DH11	t ±0.15	rpm _{max}	D ^{H11}	t ± 0.15	rpm _{max}
No. 30	10	4.65	90000	12	8.15	68000	12	6.15	68000
No. 40	10	4.65	75000	12	8.15	54000	12	6.15	54000
No. 45	10	4.65	66000	12	8.15	43000	12	6.15	43000
No. 50	10	4.65	59000	12	8.15	33000	12	6.15	33000

Dimensions in mm

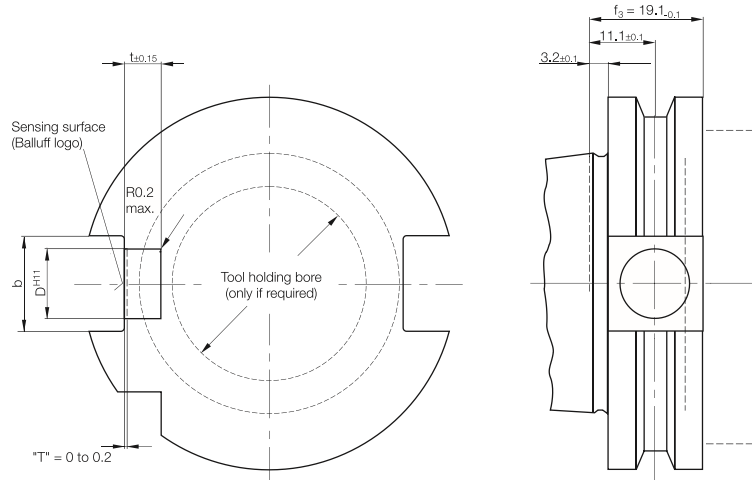

Installation in retention knob

Data Carriers	BIS C-122		BIS C-103		BIS C-105	
Taper DIN 69871-A	D ^{H11}	t ±0.15	D ^{H11}	t ±0.15	D ^{H11}	t ±0.15
No. 30						
No. 40	10	4.65				
No. 45	10	4.65	12	8.15	12	6.15
No. 50	10	4.65	12	8.15	12	6.15

Dimensions in mm

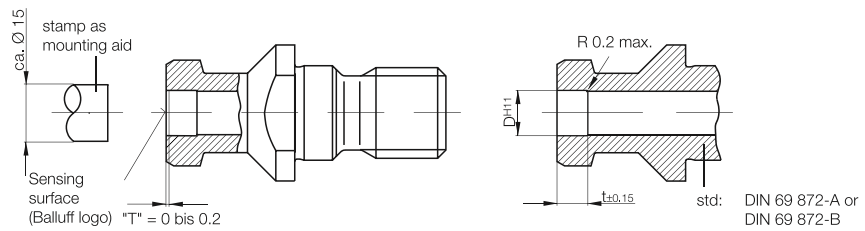

Installation:

1. Degrease gluing surfaces.
2. Apply a bead of glue approximately 3 mm wide around the perimeter of the data carrier housing (recommended glue e.g. LOCTITE Hysol 1C or UHU-Plus endfest 300), observe manufacturer's processing instructions
3. Press in data carrier housing manually, observe dimension "T"
4. Remove excess glue
5. Allow to cure

Installation in hollow shank taper HST

Data Carriers	BIS C-122	
HST Form A ISO/DIN 12164-1	$h_{3+0.20}$	rpm _{max}
32	5.4	96000
49	5.2	80000
50	5.1	75000
63	5	65000
80	4.9	57000
100	4.9	48000

Dimensions in mm

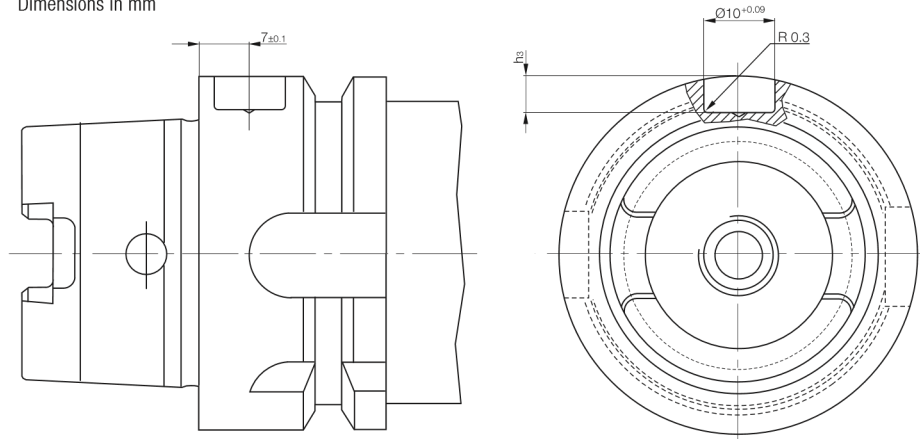

Mechanical strength

Data carriers and read/write heads BIS C-1xx, BIS C-3xx	
Shock load	100 g/6 ms per EN 60068-2-27 and 100 g/2 ms per EN 60068-2-29
Vibration	20 g, 10...2000 Hz per EN 60068-2-6

Values apply to data carriers BIS C-1xx and read/write heads BIS C-3xx except for the non-potted read/write heads BIS C-350, BIS C-351, BIS C-352 and BIS C-355.

Processor units and non-potted read/write heads BIS C-6xxx, BIS C-350, BIS C-351, BIS C-352, BIS C-355	
Shock load	15 g/11 ms per EN 60068-2-27 and 15 g/6 ms per EN 60068-2-29
Vibration	5 g, 10...150 Hz per EN 60068-2-6

RFID SYSTEMS LF (125 KHZ) BIS L

**easy loop®
communication module**

easy loop® provides compact read heads and a communication module for simple connection to the controller at minimal cost for extending BIS L systems. Prefabricated cable and connectors for fast, proper connections. No need to configure addresses.

Install the BIS L simply by connecting up to eight read heads on each of two lines with the easy loop® interface. One cable is all you need for the simple installation of BIS L, a separate power supply is not necessary. All processor units function independently to allow dynamic operation: Data is transferred reliably when the data carrier passes by.

Read times BIS L-1xx

Serial number detection typically 110 ms*

Data carrier with 4 byte blocks	
Bytes	Read time
From 0 to 3	180 ms
For each additional started 4 bytes add additional	90 ms

Read times BIS L-1xx

Serial number detection = reading data carriers = typically 100 ms*

Write times BIS L-1xx

Data carrier with 4 byte blocks	
Bytes	Write time
From 0 to 3	305 ms
For each additional started 4 bytes add additional	215 ms

*Only applies to the parameter type and output of the serial number.

All information is provided as general values. Deviations are possible depending on the application and combination of read/write head and data carrier.

Minimum distance between two data carriers

	BIS L-100-01/L	BIS L-101-01/L	BIS L-102-01/L	BIS L-103-05/L	BIS L-200-03/L	BIS L-100-05/L-RO	BIS L-201-03/L	BIS L-101-05/L-RO	BIS L-202-03/L	BIS L-102-05/L-RO	BIS L-203-03/L	BIS L-103-05/L-RO	BIS L-150-05/A
BIS VL-300-001-S4	250	300	400	250	250	250	300	300	400	400	250	250	
BIS VL-301-001-S4	300	400	500	350	350	350	400	400	500	500	350	350	
BIS VL-302-001-S4	300	400	500	350	350	350	400	400	500	500	350	350	
BIS VL-304-001-S4	150	200	200	180	180	180	200	200	250	250	180	180	
BIS VL-306-001-S4	80			50							50		
BIS VL-350-001-S4													50

Dimensions in mm

Minimum distance between two read/write heads

BIS VL-300-001-S4	400
BIS VL-301-001-S4	800
BIS VL-302-001-S4	200
BIS VL-304-001-S4	200
BIS VL-306-001-S4	100
BIS VL-350-001-S4	100

Dimensions in mm