

System overview

1

Chain bracket

Chain bracket angle

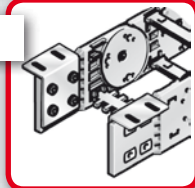

Chain bracket U-part

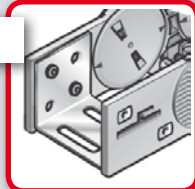

2

Shelving system

Separator TR



H-shaped shelf unit RE



1

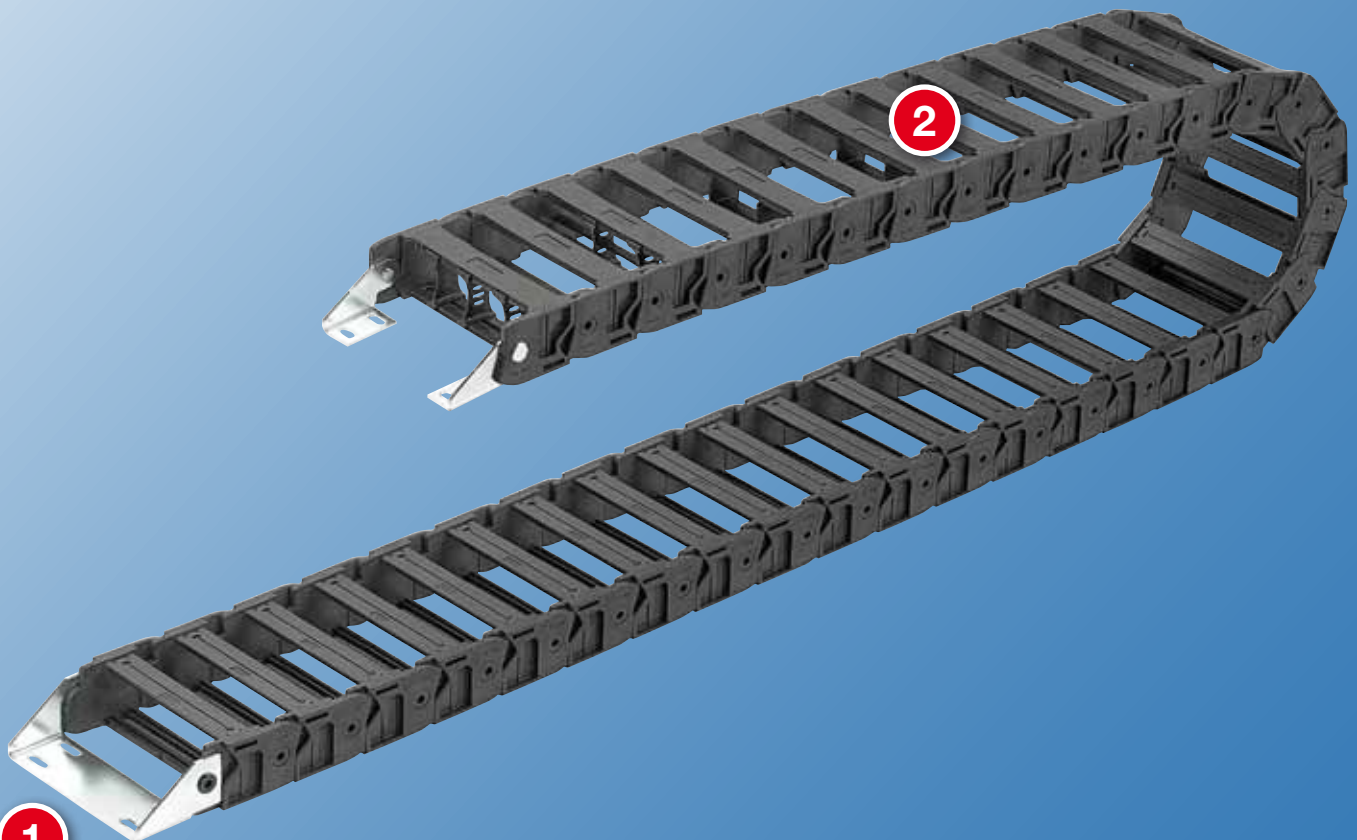

Guide channels

Aluminium VAW

Stainless steel VAW-E



Technical data

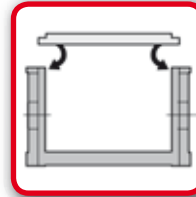

Loading side

Inside bend

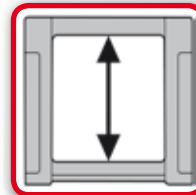

Available interior heights

34.0 mm

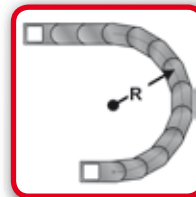

Available radii

70.0 – 300.0 mm

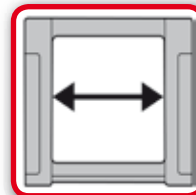

Available interior widths

62.0 – 150.0 mm

Ordering key

Type	Variation				Ridge version		Chain length mm
	Inside width mm	Outside width mm	Radius mm	Material			
0350	62 86 102 125 150	82 106 122 145 170	70 100 150 200 300	0 1	0 9		
Ordering key <div style="display: flex; justify-content: space-around; align-items: center;"> <div style="border: 1px solid black; padding: 2px;">_ _ _</div> <div style="border: 1px solid black; padding: 2px;">_ _</div> <div style="border: 1px solid black; padding: 2px;">_ _</div> <div style="border: 1px solid black; padding: 2px;">_ _ _</div> <div style="border: 1px solid black; padding: 2px;">_</div> <div style="border: 1px solid black; padding: 2px;">_</div> <div style="border: 1px solid black; padding: 2px;">_ _ _ _ _</div> </div>							

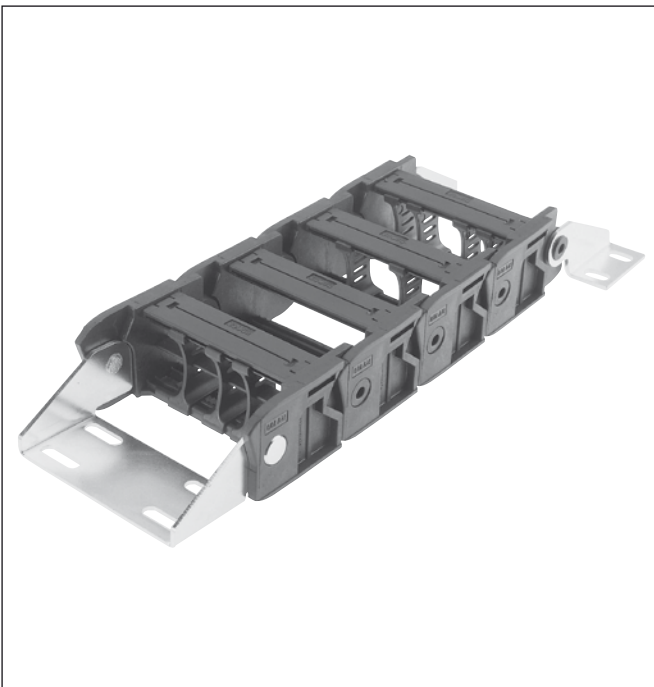

Chain link

Loading side:

Inside bend

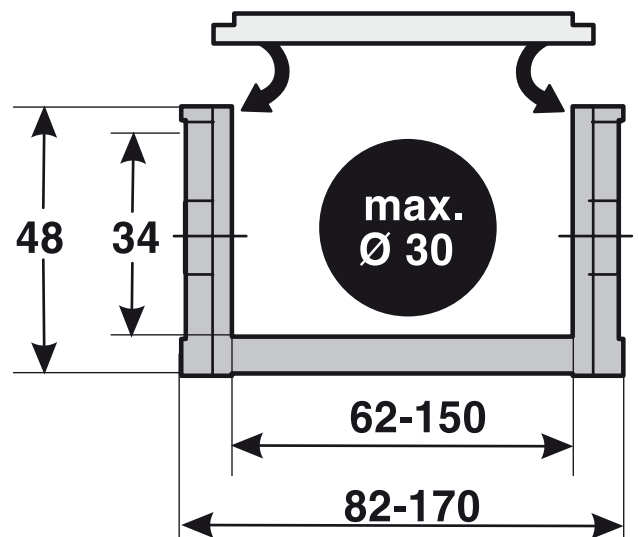

Dimensions in mm

0 Standard (PA/black)
9 Special version

0 PA full-ridged with bias
1 PA full-ridged without bias

02 Frame bridge on outside of radius
Frame bridge on inside of radius
Opens on inside of radius

Order sample: 0350 02 062 070 0 0 1276

Frame bridge in outside bend, frame bridge in inside bend, can be opened from inside bend
Inside width 62 mm; radius 70 mm
Plastic bridge, full-ridged with bias, material black-coloured polyamide
Chain length 1276 mm (22 links)

Technical specifications

Travel distance gliding L_g max.:	80.0 m
Travel distance self-supporting L_f max.:	see diagram
Travel distance vertical, hanging L_{vh} max.:	40.0 m
Travel distance vertical, upright L_{vs} max.:	3.0 m
Rotated 90°, unsupported L_{90f} max.:	1.0 m
Speed, gliding V_g max.:	3.0 m/s
Speed, self-supporting V_f max.:	10.0 m/s
Acceleration, gliding a_g max.:	15.0 m/s ²
Acceleration, self-supporting a_f max.:	20.0 m/s ²

Material properties

Standard material:	Polyamide (PA) black
Service temperature:	-30.0 – 120.0 °C
Gliding friction factor:	0.3
Static friction factor:	0.45
Fire classification:	Based on UL 94 HB
Other material properties on request.	

Determining the chain length

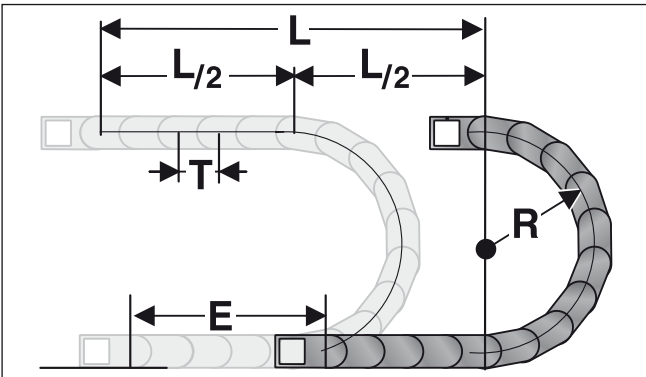

The fixed point of the cable drag chain should be connected in the middle of the travel distance. This arrangement gives the shortest connection between the fixed point and the moving consumer and thus the most efficient chain length.

$$\text{Chain length calculation} = L/2 + \pi * R + 2 * T + E$$

≈ 1 m chain = x 58.0 mm links.

E = distance between entry point and middle of travel distance
L = travel distance
R = radius
P = Pitch

Self-supporting length

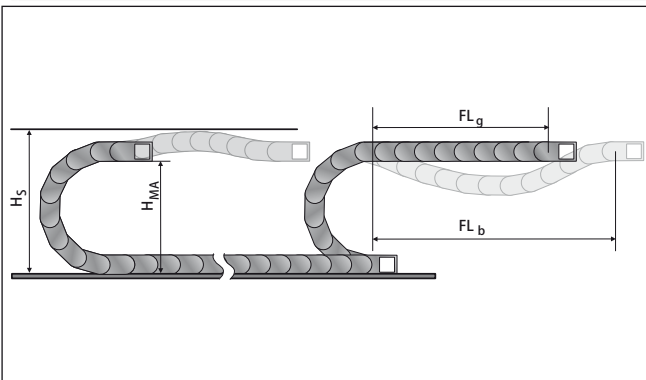

The self-supporting length is the distance between the chain bracket on the moving end and the start of the chain arch.

The installation variant FL_g offers the lowest load and wear for the cable drag chain.

The maximum travel parameters (speed and acceleration) can be applied for this variant.

H_S = Installation height plus safety
 H_{MA} = Height of moving end connection
 FL_g = Self-supporting length, upper run straight
 FL_b = Self-supporting length, upper run bent

Load diagram for self-supporting applications

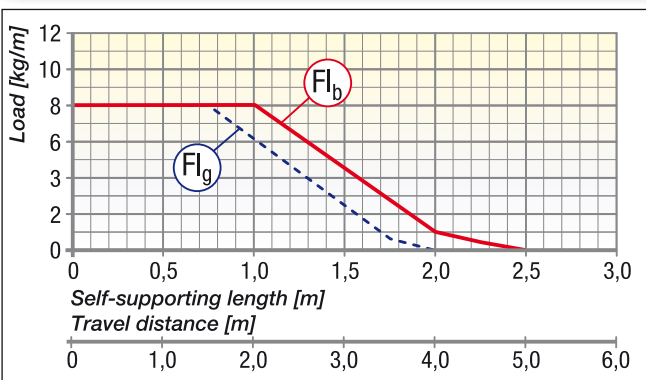

FL_g Self-supporting Length, upper run straight

In the FL_g range, the chain upper run still has a bias, is straight or has a maximum sag of

FL_b Self-supporting Length, upper run bent

In the FL_b range, the chain upper run has a sag of more than , but this is still less than the maximum sag. Where the sag is greater than that permitted in the FL_b range, the application is critical and should be avoided. The self-supporting length can be optimized by using a support for the upper run or a more stable cable drag chain.

Installation dimensions

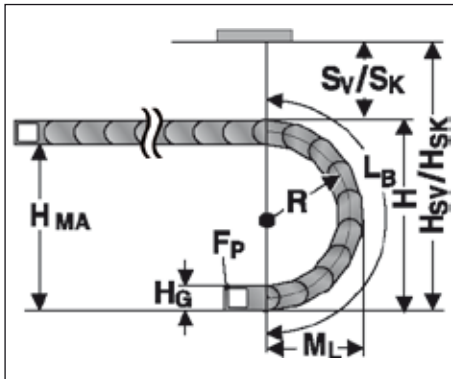

Radius R	70	100	150	200	300
Outside height of chain link (H_v)	48	48	48	48	48
Height of bend (H)	188	248	348	448	648
Height of moving end connection (H_{MA})	140	200	300	400	600
Safety margin with bias (S_v)	40	40	40	40	40
Installation height with bias (H_{SV})	228	288	388	488	688
Safety margin without bias (S_K)	15	15	15	15	15
Installation height without bias (H_{SK})	203	263	363	463	663
Arc projection (M_L)	152	182	232	282	382
Bend length (L_B)	353	447	604	761	1075

Chain bracket angle

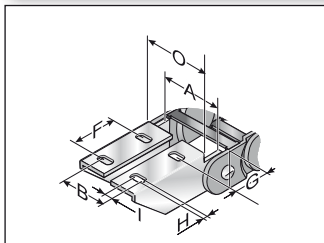

KA 35... (Inside up / down)

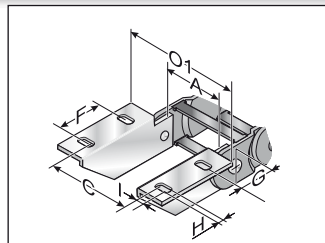

KA 35... (Outside up / down)

The chain bracket can be supplied either in galvanised sheet steel or stainless steel. To secure one cable drag chain, you will need two angle brackets (left and right) with a drilled hole and two angle brackets (left and right) with a bolt. The order numbers given below each comprise a left and right angle bracket.

Type	Order no.	Material	Inside width							Outside width KA O mm	Outside width KA O1 mm
			A mm	B mm	C mm	F mm	G mm	HØ mm	I mm		
KA 3508 male	0350000054	Sheet steel	62.0 – 150.0	A-7.0	A+28.0	25.0	20.0	7.0	8.0	A+20.0	A+52.0
KA 3508 female	0350000055	Sheet steel	62.0 – 150.0	A-12.0	A+38.5	25.0	20.0	7.0	8.0	A+10.0	A+52.0
KA 3509 male	0350000056	Stainless steel 1.4301	62.0 – 150.0	A-7.0	A+28.0	25.0	20.0	7.0	8.0	A+20.0	A+52.0
KA 3509 female	0350000057	Stainless steel 1.4301	62.0 – 150.0	A-12.0	A+38.5	25.0	20.0	7.0	8.0	A+10.0	A+52.0

Chain bracket U-part

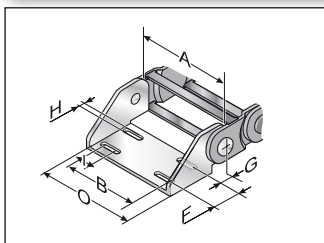

KA 35062 – 35150

The metal connection (U-section) is precisely adjusted to the respective chain width. It only needs to be snapped in the chain link. Please order one male and one female end bracket for each chain. The brackets should be fastened with M6 screws.

Type	Order no.	Material	Inside width A mm	B mm	F mm	G mm	HØ mm	I mm	Outside width KA O mm
KA 35062 male	035000007000	Sheet steel	62.0	A-7.0	25.0	20.0	7.0	15.0	A+20.0
KA 35062 female	035000007100	Sheet steel	62.0	A-12.0	25.0	20.0	7.0	15.0	A+20.0
KA 35086 male	035000007200	Sheet steel	86.0	A-7.0	25.0	20.0	7.0	15.0	A+20.0
KA 35086 female	035000007300	Sheet steel	86.0	A-12.0	25.0	20.0	7.0	15.0	A+20.0
KA 35102 male	035000007400	Sheet steel	102.0	A-7.0	25.0	20.0	7.0	15.0	A+20.0
KA 35102 female	035000007500	Sheet steel	102.0	A-12.0	25.0	20.0	7.0	15.0	A+20.0

Shelving system

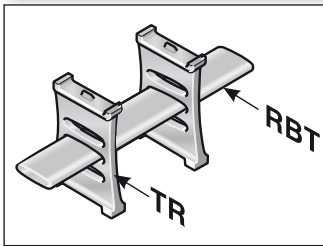

The shelf must be used with a minimum of two separators to create a shelving system. The additional levels prevent cables from criss-crossing and therefore destroying each other, while also avoiding excessive friction. The shelves are matched to the available chain widths.

Type	Order no.	Designation	Width mm	Pitch mm
RBT 062	100000006200	Shelf	62.0	3.0
RBT 086	100000008600	Shelf	86.0	3.0
RBT 101	100000010100	Shelf	101.0	3.0
RBT 125	100000012500	Shelf	125.0	3.0
RBT 150	100000015000	Shelf	150.0	3.0

Separator

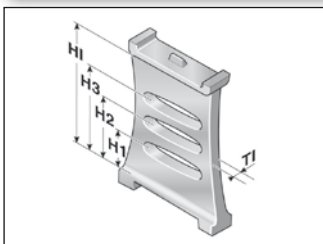

We recommend that separators be used if multiple round cables or conduits with differing diameters are to be installed. An offset configuration of the separators is advisable.

Separator

Type	Order no.	Designation	Version	Pitch mm	T1 mm	H mm	H1 mm	H2 mm	H3 mm	H1 mm
TR 35	035000009200	Separator	lockable	3.0	2.0	2.5	10.9	16.9	22.9	33.8

Shelf unit

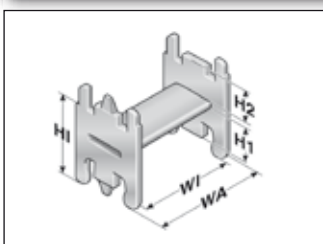

Insert to obtain additional levels in pre-defined window distances.

Shelf unit

Type	Order no.	Designation	Pitch mm	WA mm	WI mm	H1 mm	H2 mm	H1 mm
RE 35/33	100000353310	H-shaped shelf unit	3.0	35.5	30.5	18.0	12.0	33.0
RE 35/48	100000354810	H-shaped shelf unit	3.0	50.5	45.5	18.0	12.0	33.0
RE 35/57	100000355710	H-shaped shelf unit	3.0	59.5	54.5	18.0	12.0	33.0

Guide channels (VAW)

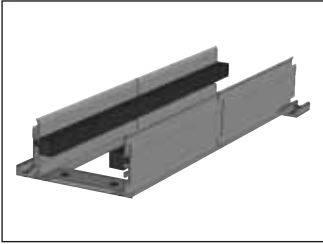

VAW



VAW-E

For this cable drag chain, a range of variable guide channel systems are available, constructed from aluminium or stainless steel sections. The variable guide channel ensures that the cable drag chain is supported and guided securely. For help on choosing, please consult the chapter „Variable Guide Channel System“.

Assembly

Disassembly

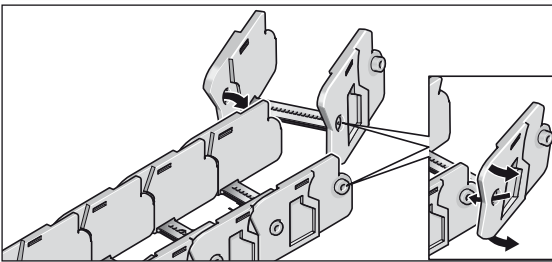

Step 1

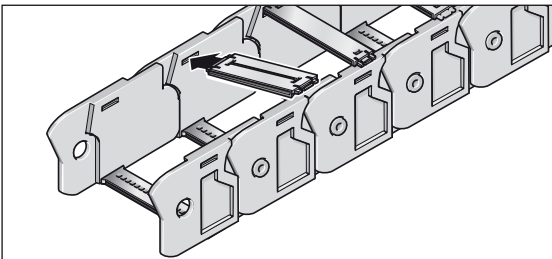

Step 2

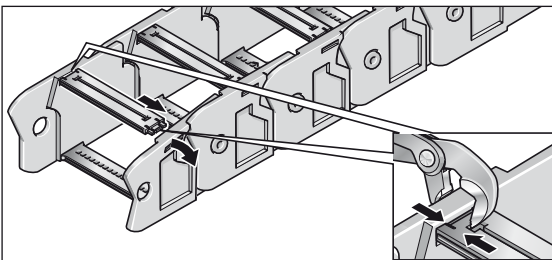

Step 3

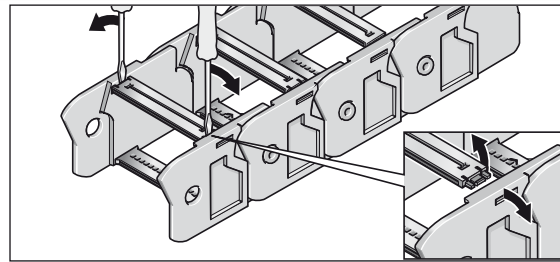

Step 1

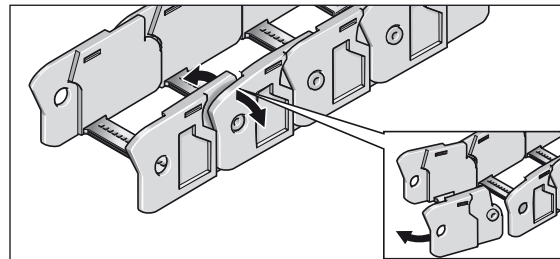

Step 2

