

System overview

1

Chain bracket

Chain bracket flexible

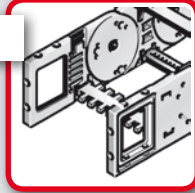

2

Strain relief

Frame bridge RS-ZL

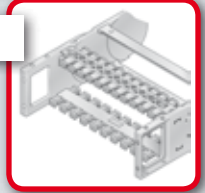

STF Steel Fix

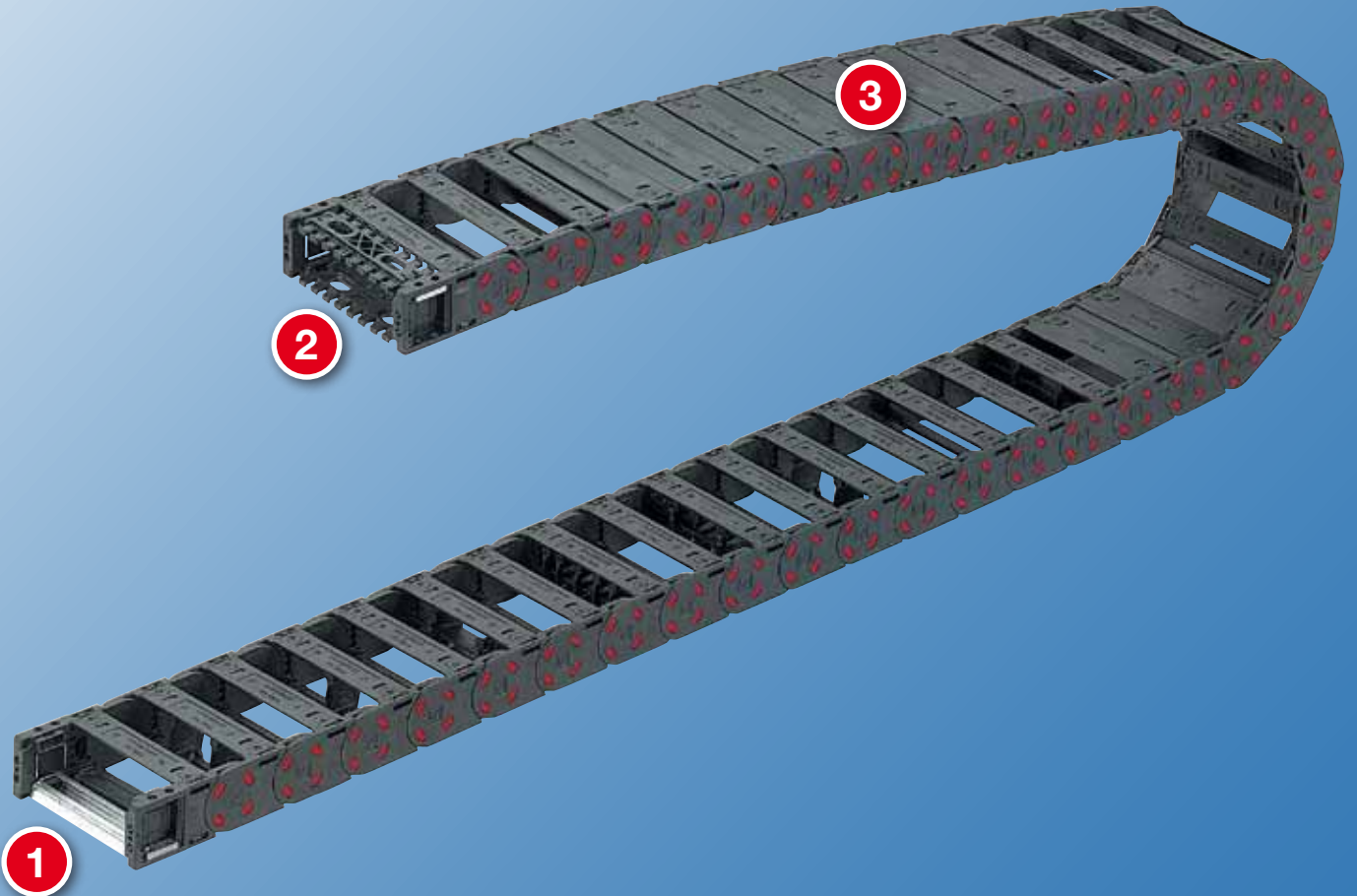
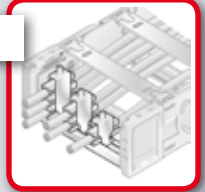

3 Shelving system

Separator TR



Shelf, end-to-end RBD



Guide channels

Aluminium VAW

Stainless steel VAW-E



Technical data



Loading side
Inside or outside flexure curve

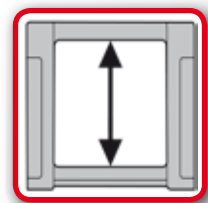

Available interior heights
30.0 mm

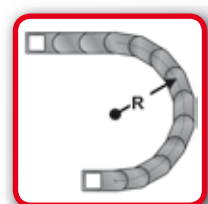

Available radii
60.0 – 300.0 mm

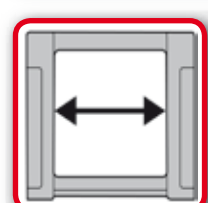

Available interior widths
40.0 – 200.0 mm

Ordering key

Type	Variation	Dimensions			Ridge version		Material
		Inside width mm	Outside width mm	Radius mm	0	9	
0030	01	40	56	60 ¹⁾	0	0	1) for Variant 30 only Chain length mm
	02	50	66	75 ¹⁾	1	9	
	03	60	76	100			
	04	75	91	125			
	05	85	101	150			
	06	100	116	200			
	07	125	141	250			
	08	150	166	300			
		200	216				

Ordering key	Dimensions	Ridge version	Material
0030	01-08	0-1	0-9



Chain link

Loading side: Inside or outside flexure curve

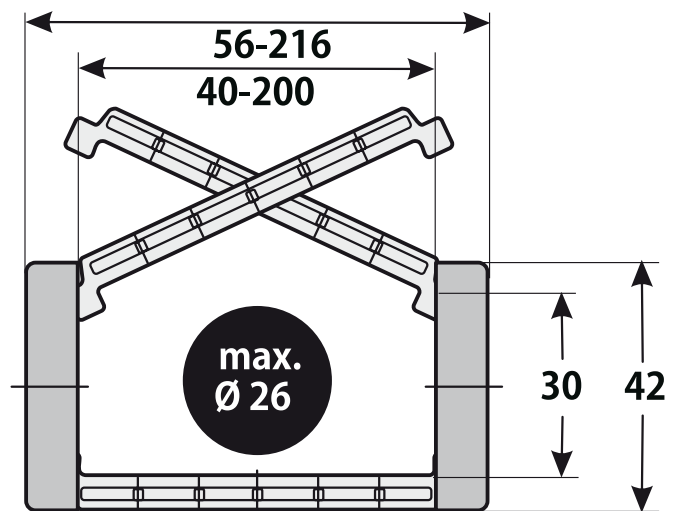

Dimensions in mm

0 Standard (PA/black)
9 Special version

0 PA full-ridged with bias
1 PA full-ridged without bias

- 01 Frame bridge on outside of radius
Frame bridge on inside of radius
Opens on outside of radius
- 02 Frame bridge on outside of radius
Frame bridge on inside of radius
Opens on inside of radius
- 03 Cover on outside of radius
Cover on inside of radius
Opens on outside of radius
- 04 Cover on outside of radius
Cover on inside of radius
Opens on inside of radius
- 05 Cover on outside of radius
Frame bridge on inside of radius
Opens on outside of radius
- 06 Cover on outside of radius
Frame bridge on inside of radius
Opens on inside of radius
- 07 Frame bridge on outside of radius
Cover on inside of radius
Opens on outside of radius
- 08 Frame bridge on outside of radius
Cover on inside of radius
Opens on inside of radius

Order sample: 0030 01 040 060 0 0 1250

Frame bridge in outside bend, frame bridge in inside bend, can be opened from outside bend
Inside width 40 mm; radius 60 mm
Plastic bridge, full-ridged with bias, material black-coloured polyamide
Chain length 1250 mm (25 links)

Technical specifications

Travel distance gliding L_g max.:	40.0 m
Travel distance self-supporting L_f max.:	see diagram
Travel distance vertical, hanging L_{vh} max.:	30.0 m
Travel distance vertical, upright L_{vs} max.:	3.0 m
Rotated 90°, unsupported L_{90f} max.:	0.7 m
Speed, gliding V_g max.:	3.0 m/s
Speed, self-supporting V_f max.:	10.0 m/s
Acceleration, gliding a_g max.:	10.0 m/s ²
Acceleration, self-supporting a_f max.:	15.0 m/s ²

Material properties

Standard material:	Polyamide (PA) black
Service temperature:	-20.0 – 100.0 °C
Gliding friction factor:	0.3
Static friction factor:	0.45
Fire classification:	UL 94 HB
Other material properties on request.	

Determining the chain length

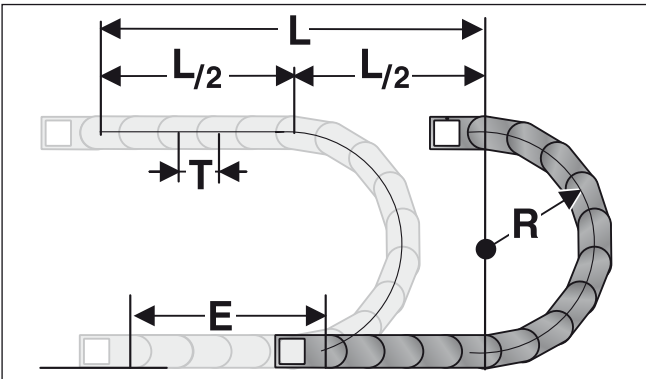

The fixed point of the cable drag chain should be connected in the middle of the travel distance. This arrangement gives the shortest connection between the fixed point and the moving consumer and thus the most efficient chain length.

$$\text{Chain length calculation} = L/2 + \pi * R + E$$

$$\approx 1 \text{ m chain} = 20 \text{ qty.} \times 50.0 \text{ mm links.}$$

E = distance between entry point and middle of travel distance
L = travel distance
R = radius
P = Pitch

Self-supporting length

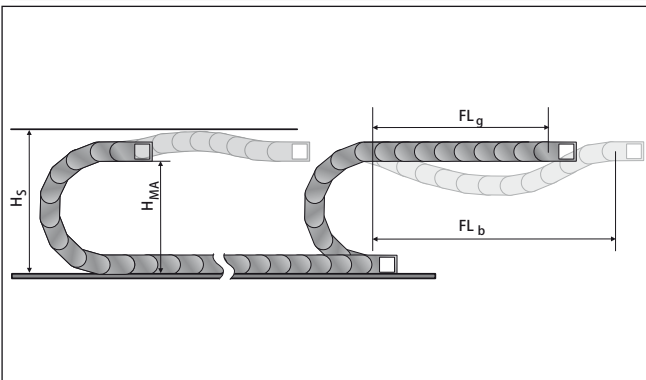

The self-supporting length is the distance between the chain bracket on the moving end and the start of the chain arch.

The installation variant FL_g offers the lowest load and wear for the cable drag chain.

The maximum travel parameters (speed and acceleration) can be applied for this variant.

H_S = Installation height plus safety
 H_{MA} = Height of moving end connection
 FL_g = Self-supporting length, upper run straight
 FL_b = Self-supporting length, upper run bent

Load diagram for self-supporting applications

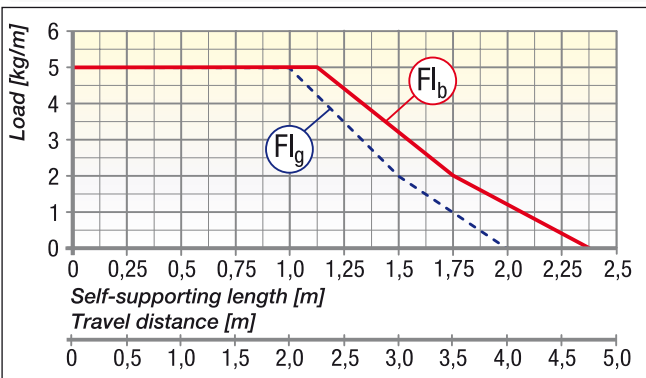

FL_g Self-supporting Length, upper run straight

In the FL_g range, the chain upper run still has a bias, is straight or has a maximum sag of

FL_b Self-supporting Length, upper run bent

In the FL_b range, the chain upper run has a sag of more than , but this is still less than the maximum sag. Where the sag is greater than that permitted in the FL_b range, the application is critical and should be avoided. The self-supporting length can be optimized by using a support for the upper run or a more stable cable drag chain.

Closed cable drag chains (with covers) have a higher unit weight than open chains (with frame bridges). This higher weight must be taken into account when calculating the

self-supporting length. To the weight of the cabling (cable load, in kg/m), you must add 0.3 kg/m, to account for the higher weight of closed-cover chains.

Installation dimensions

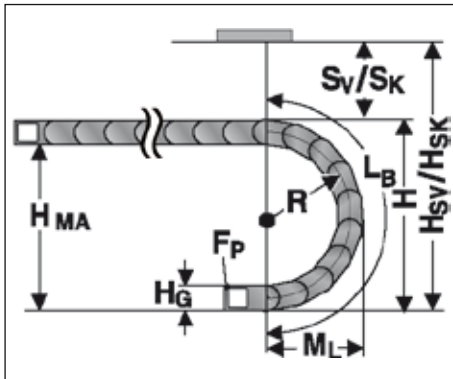

Radius R	60	75	100	125	150	200	250	300
Outside height of chain link (H_{v})	42	42	42	42	42	42	42	42
Height of bend (H)	182	212	262	312	362	462	562	662
Height of moving end connection (H_{MA})	140	170	220	270	320	420	520	620
Safety margin with bias (S_{v})	38	38	38	38	38	38	38	38
Installation height with bias (H_{SV})	220	250	300	350	400	500	600	700
Safety margin without bias (S_{K})	18	18	18	18	18	18	18	18
Installation height without bias (H_{SK})	200	230	280	330	380	480	580	680
Arc projection (M_{L})	141	156	181	206	231	281	331	381
Bend length (L_{B})	336	383	461	540	618	775	932	1089

Chain bracket flexible

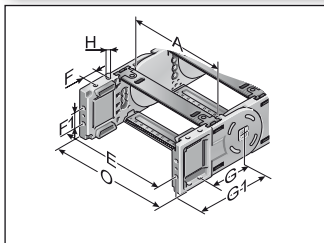

Chain bracket

This chain bracket offers universal connection options (top, bottom and front) and is attached to the ends of the chain like a side link. This allows the chain to move right up to the bracket. Each chain requires one male and one female bracket. M5 screws and insert panels are used to secure the brackets in place.

By default, the chain bracket is supplied with frame bridges.

The chain connection can then be optionally fitted with frame bridge strain relief RS-ZL or with strain relief using C-rails and bow clamps type STF.

Type	Order no.	Material	Inside width								Outside width KA O
			A mm	E mm	F mm	F1 mm	G mm	G1 mm	H mm	H0 mm	
KA30	KA30ML	Plastic	40.0 – 200.0	A+9.0	12.0	12.0	45.0	72.0	M5	5.5	A+18.0

Configurator chain bracket KA 30

Configurator for chain brackets:

Type KA	Inside width mm	Radius mm	No. of RS-ZL Pieces	C-Profile No. Pieces	EB** No. Pieces
KA 30*	085	250	2	0	2

Order sample:

Type	= KA 30 = Chain bracket, flexible, for MP 30
Inner width	= 085 mm
Radius	= 250 mm
Frame bridge strain relief plate (RS-ZL)	= 2 pieces
C-section	= 0 pieces
Insert panel (EB)	= 2 pieces

* One set chain bracket is needed per chain, containing male and female end

** Two insert panels (EB) are needed per connection element

Note:

For an exact determination of the chain bracket, the inside width and radius are absolutely essential. Optionally frame bridge strain relief plates (RS-ZL), C-profiles and insert panels (EB) can be chosen.

Shelving system

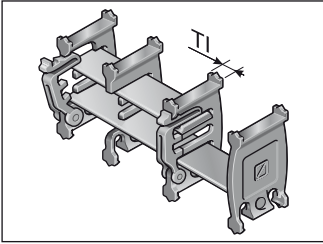

Shelving system

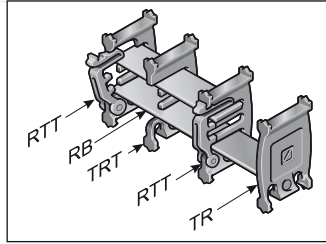

In connection with at least two separable shelf supports RTT or separable separators TRT the shelf becomes a shelving system that can be placed anywhere in the chain link. The shelf RBD creates a horizontal separation over the entire width of the chain link. If necessary the separator TRT can also be built in. The additional levels prevent cables from criss-crossing. Pre-assembly is not necessary as the shelving system and cabling can be assembled quickly and easily on site.

Type	Order no.	Designation	Pitch mm
TRT 25	025100009200	Separator, divisible	2.5
RTT 25	025100006500	Shelf support, divisible	2.5

Separator

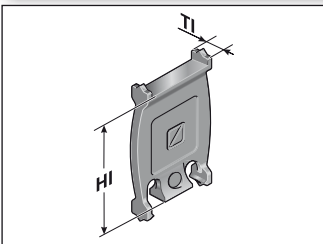

Separator, closed

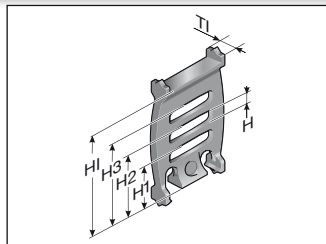

Separator, open

We recommend that separators be used if multiple round cables or conduits with differing diameters are to be installed. An offset configuration of the separators is advisable.

Type	Order no.	Designation	Version	Pitch mm	TI mm	H mm	H1 mm	H2 mm	H3 mm	HI mm
TR 30-0	030100009300	Separator, closed	lockable	2.5	2.2	3.3	11.0	16.5	22.0	36.0
TR 30-1	030100009400	Separator, open	lockable	2.5	2.2	3.3	11.0	16.5	22.0	30.0
TRT 30	030100009200	Separator, divisible	lockable	2.5	2.2	3.3	11.0	16.5	22.0	
RTT 30	030100006500	Shelf support, divisible	lockable	2.5	2.2	3.3	11.0	16.5	22.0	

Shelf

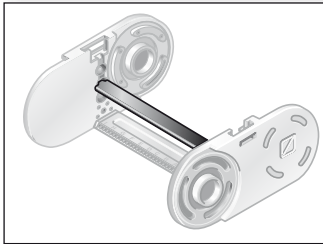

Shelf, end-to-end RBD

The shelf RBD creates a horizontal separation over the entire width of the chain link. When used together with the TRT 25 separator, an additional, vertical division can be realised.

Type	Order no.	Designation	Width mm	For internal width mm
RBD 040-3	030100004001	Shelf, end-to-end		40.0
RBD 050-3	030100005001	Shelf, end-to-end		50.0
RBD 060-3	030100006001	Shelf, end-to-end		60.0
RBD 075-3	030100007501	Shelf, end-to-end		75.0
RBD 085-3	030100008501	Shelf, end-to-end		85.0
RBD 100-3	030100010001	Shelf, end-to-end		100.0
RB 039-3	030100003900	Shelf	39.0	
RB 049-3	030100004900	Shelf	49.0	
RB 059-3	030100005900	Shelf	59.0	
RB 074-3	030100007400	Shelf	74.0	
RB 084-3	030100008400	Shelf	84.0	
RB 099-3	030100009900	Shelf	99.0	
RB 124-3	030100012400	Shelf	124.0	
RB 149-3	030100014900	Shelf	149.0	
RB 199-3	030100019900	Shelf	199.0	

Brush support

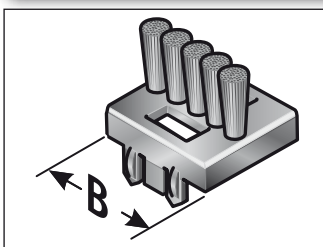

Brush support

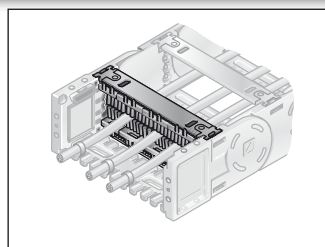

Brush support

The cables in the neutral strand are routed through the brush supports. This innovative solution was developed especially for applications where cables are subjected to higher levels of wear from cyclical movement.

Type	Order no.	Designation	Width mm
BT20-30	030100009702	Brush support	20.0
BT25-30	030100009802	Brush support	25.0

Insert panel

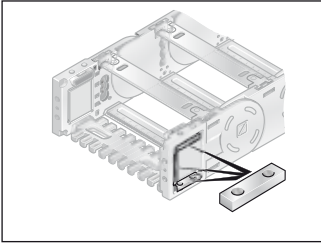

Insert panel

To fix the chain connection, the insert panels can be inserted above, below or on the side and are available with threads or through-holes.

Type	Order no.	Designation	Holes mm	Thread
EB 25/30-FG V2A	030100005502	Insert panel with thread		M5x1,5
EB 25/30-FB V2A	030100005500	Insert panel with through-hole	5.5	

Frame bridge strain relief plate

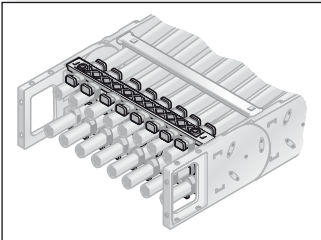

Frame bridge strain relief plate

Fixed integrated frame bridge strain relief plates in the chain brackets. Tailored to all frame bridge widths up to 200 mm. May be assembled on the inside and outside bends at both chain endings.

Type	Order no.	Designation	For internal width mm
RS-ZL 040-3	030104000010	Frame bridge strain relief plate	40.0
RS-ZL 050-3	030105000010	Frame bridge strain relief plate	50.0
RS-ZL 060-3	030106000010	Frame bridge strain relief plate	60.0
RS-ZL 075-3	030107500010	Frame bridge strain relief plate	75.0
RS-ZL 085-3	030108500010	Frame bridge strain relief plate	85.0
RS-ZL 100-3	030110000010	Frame bridge strain relief plate	100.0
RS-ZL 125-3	030112500010	Frame bridge strain relief plate	125.0
RS-ZL 150-3	030115000010	Frame bridge strain relief plate	150.0
RS-ZL 200-3	030120000010	Frame bridge strain relief plate	200.0

Strain relief

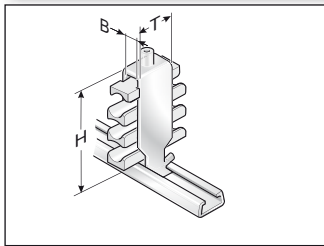

Strain relief with Steel Fix

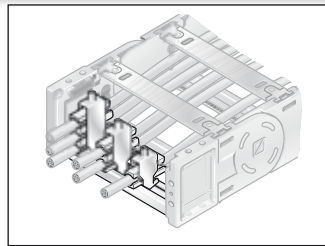

Strain relief with Steel Fix

C-rails (cathodic dipped) for permanent integration, for accommodating the Steel Fix bow clamps in the chain brackets. The bow clamps can take up to 3 cables and are suitable for C-rails with a groove width of 11 mm. Due to the design of the trough elements a cable preserving cable guidance is ensured. Adjusted to all inside widths up to 200 mm. May be assembled on the inside and outside flexure curves at both chain endings. The entire height entered is a guide only. The actual height is,

amongst other things, dependent on the diameter and the quality of the cable. A safety distance of 10 mm at the fixed point above the strain relief must be kept during gliding applications.

Type	Order no.	Designation	Ø mm	Seats qty.
Single clamp (for one cable)				
STF 12-1 Steel Fix	81661801	Hooped clamp	6.0 – 12.0	1
STF 14-1 Steel Fix	81661802	Hooped clamp	12.0 – 14.0	1
STF 16-1 Steel Fix	81661803	Hooped clamp	14.0 – 16.0	1
STF 18-1 Steel Fix	81661804	Hooped clamp	16.0 – 18.0	1
STF 20-1 Steel Fix	81661805	Hooped clamp	18.0 – 20.0	1
STF 22-1 Steel Fix	81661806	Hooped clamp	20.0 – 22.0	1
STF 26-1 Steel Fix	81661807	Hooped clamp	22.0 – 26.0	1
STF 30-1 Steel Fix	81661808	Hooped clamp	22.0 – 26.0	1
STF 34-1 Steel Fix	81661809	Hooped clamp	26.0 – 30.0	1
STF 38-1 Steel Fix	81661810	Hooped clamp	34.0 – 38.0	1
STF 42-1 Steel Fix	81661811	Hooped clamp	38.0 – 42.0	1
Double clamp (for two cables)				
STF 12-2 Steel Fix	81661821	Hooped clamp	6.0 – 12.0	2
STF 14-2 Steel Fix	81661822	Hooped clamp	12.0 – 14.0	2
STF 16-2 Steel Fix	81661823	Hooped clamp	14.0 – 16.0	2
STF 18-2 Steel Fix	81661824	Hooped clamp	16.0 – 18.0	2
STF 20-2 Steel Fix	81661825	Hooped clamp	18.0 – 20.0	2
STF 22-2 Steel Fix	81661826	Hooped clamp	20.0 – 22.0	2
STF 26-2 Steel Fix	81661827	Hooped clamp	22.0 – 26.0	2
STF 30-2 Steel Fix	81661828	Hooped clamp	26.0 – 30.0	2
STF 34-2 Steel Fix	81661829	Hooped clamp	26.0 – 30.0	2
Triple clamp (for three cables)				
STF 12-3 Steel Fix	81661841	Hooped clamp	6.0 – 12.0	3
STF 14-3 Steel Fix	81661842	Hooped clamp	12.0 – 14.0	3
STF 16-3 Steel Fix	81661843	Hooped clamp	14.0 – 16.0	3
STF 18-3 Steel Fix	81661844	Hooped clamp	16.0 – 18.0	3
STF 20-3 Steel Fix	81661845	Hooped clamp	18.0 – 20.0	3
STF 22-3 Steel Fix	81661846	Hooped clamp	20.0 – 22.0	3

Guide channels (VAW)

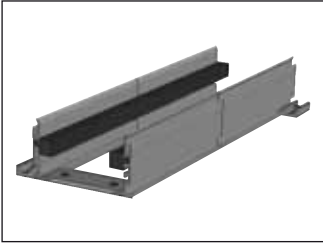

VAW



VAW-E

For this cable drag chain, a range of variable guide channel systems are available, constructed from aluminium or stainless steel sections. The variable guide channel ensures that the cable drag chain is supported and guided securely. For help on choosing, please consult the chapter „Variable Guide Channel System“.

Assembly

Disassembly

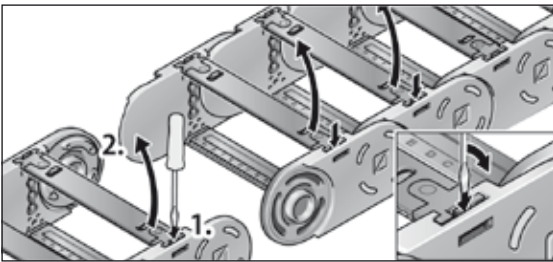

Step 1

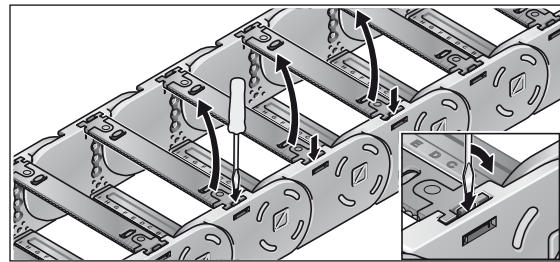

Step 1

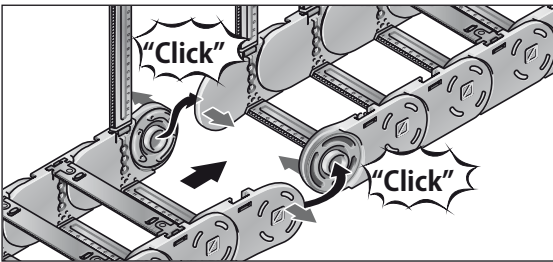

Step 2

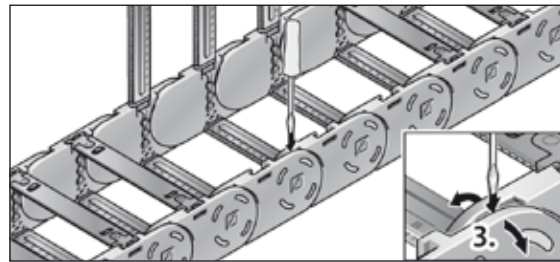

Step 2

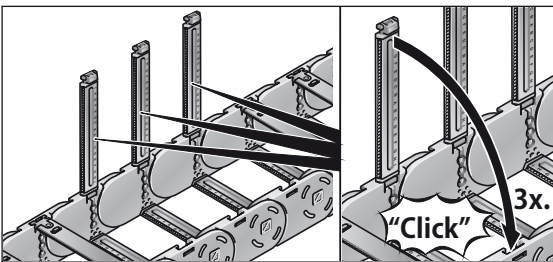

Step 3

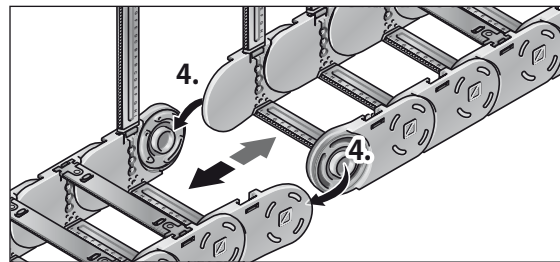

Step 3

