

Festoon Systems for C-Rails

Program 0240



CONDUCTIX
wampfler

Ⓞ DELACHAUX GROUP

Contents

System Arrangement Program 0240

Rails and Mounting Parts	3
Festoon Systems for Flat Cables	3
Festoon Systems for Round Cable	3

C-Rails and Accessories Program 0240

C-Rails	4
90°- Curves	4
Track Couplers	5
Track Couplers, Two-Piece	5
Track Support Bracket, One-Piece, for Ceiling Attachment	6
Track Support Bracket, One-Piece, with Square Nut for Attachment to Support Arms	6
Track Support Bracket, One-Piece, for Attachment to Existing Steel Structure	6
Track Support Brackets, Three-Piece, for Ceiling Attachment	7
Track Support Brackets, Three-Piece, with Square Nut for Attachment to Support Arms	7
Track Support Brackets, Three-Piece, for Attachment to the Existing Steel Structure	7
Track Support Bracket for Attachment to the Existing Steel Structure	8
Track Support Bracket and Coupler, One-Piece, for Ceiling Attachment	8
Track Support Bracket and Coupler, One-Piece with Square Nut for Attachment to Support Arms	8
Track Support Bracket and Coupler, One-Piece for Attachment to the Existing Steel Structure	8
Track Support Brackets for Attachment to the Existing Steel Structure	9
Track Support Bracket, bare to weld on	10
Track Support Bracket and Coupler, bare to weld on	10
Track Support Bracket for Direct Attachment below I-Beams	10
Bolt Complete	10
Support Arms 40x40x2.5 - punched	11
Support Arms 40x40x2.5 - unpunched	11
Permissible Load for Support Arms	12
Bracket for Support Arms 40x40x2.5 to be bolted with 2-Hole Connecting Plate	12
Bracket for Support Arms 40x40x2.5 to be bolted with 4-Hole Connecting Plate	12
Console Brackets to be bolted with 4-Hole Connecting Plate	13
Brackets, bare to be welded	13
Girder Clips, Clamping Thickness 4 - 20 mm	14
Girder Clips, Clamping Thickness 18 - 36 mm	14
Girder Clips, Twist-Secured, Clamping Thickness 6 - 25 mm	14
Girder Clips, Reinforced Type, Clamping Thickness 6 - 21 mm	15
Girder Clips, Reinforced Type, Clamping Thickness 6 - 30 mm	15
Application Examples for Support Arm and C-Rail Fastening with Support Arms – unpunched	16
Application Examples for Support Arm and C-Rail Fastening with Support Arms – punched	16
Application Example for Support Arm and C-Rail Fastening with Welded Brackets	16
End Stop with Rubber Buffer	17
End Stop without Rubber Buffer	17
Application Example for End Stop Assembly	17
Towing Arms	18
End Caps	18
CI-Rail Reinforced Type, Wall Thickness 3.0 mm	19
Track Coupler	19
Track Support Bracket	19
CV-Rail Reinforced Type, Wall Thickness 3.0 mm	20
Track Coupler	20

Cable Trolleys for Flat Cables Program 0240

Steel Cable Trolley with Plastic Cable Support	21
Steel Cable Trolleys, Light Series without Buffer	22
Steel Cable Trolleys, Light Series with Buffer	22
Steel Cable Trolleys, Heavy Series	23

Cable Trolleys for Round Cables Program 0240

Steel Cable Trolleys with Ball Joint for Cable Clips 020131, Light Series without Buffer	24
Steel Cable Trolleys with Ball Joint for Cable 020131, Heavy Series with Buffer	24
Steel Cable Trolleys with Bracket for Cable Clips 020133, Heavy Series with Buffer	25
Cable Clips for Fixation at the Ball Joint	26
Cable Clips for Fixation at the Bracket	26
Additional Cable Clips for Combinations with Sizes 50 and 63 of Types 020133	26
Hose Clip for Fixation at the Ball Joint	27
Hose Clip for Fixation at the Bracket	27
Cable Trolley with Cable Clips, Heavy Series, Rotatable	28
Steel Cable Trolleys, Heavy Series for Clamping of Round Cables with a max. Difference in Diameter of 6 mm	29
Steel Cable Trolleys, Heavy Series for Clamping of Round Cables with a max. Difference in Diameter of 16 mm	30

Contents

Cable Trolleys and Accessories for Traversing, Program 0240

Transfer Guide for C-Rail 024100	31
Cable Trolleys for Flat Cables with Additional Rollers	31

Cable Trolley for Applications with Increased Horizontal Forces | Program 0240

Cable Trolleys with Horizontal Guide Rollers	32
--	----

Ideal Control Unit Trolleys Program 0240

Ideal Control Unit Trolleys with Plug and Socket Connection – Basic Configuration	33
Ideal Control Unit Trolleys with Plug and Socket Connection – Pre-Assembled	33
Ideal Control Unit Trolley with Plastic Terminal Box – Basic Configuration	34
Ideal Control Unit Trolleys with Plastic Terminal Box – Pre-Assembled	34
Ideal Control Unit Trolleys with Terminal Box of Steel – Basic Configuration	35
Control Trolley Upper Parts	35
Basic Ideal Control Unit Trolleys for Round Cables	36

Accessories for Festoon Systems Program 0240

Application Examples	37
Towing Ropes Pre-Assembled	38
Ropes	38
Shackles	38
Spring Safety Hook	38
Rope Thimbles	38
Rope Clip	39
Rope Eyes	39
Cable Clamps	39
Brake Glider	40
Brake Trolley	40
Cable Trolley Upper Parts	41
Plastic Trolleys 2 Rollers	42
Plastic Trolleys 4 Rollers	42
Steel Trolley 2 Rollers	42
Steel Trolley 4 Rollers without Buffer	42
Steel Trolley 4 Rollers with Buffer	43
S-Hook	43
Spring Safety Hook	43
Cable Collar, Plastic	43
Strap for Cable Bundle	44
Cable Clips with Bracket	44

Helpful Hints

Calculation of the Load Capacity of C-Rails	45
Load Diagram for C-Rail 40 x 40 x 2.5 (024100 / 024104 / 024109)	45
Load Diagram for CI-Rail Reinforced (024052-6)	46
Load Diagram for CV-Rail Reinforced (024030-6)	46
Technical Data	47
Formulas to Determine the Number of Loops, Cable Length and Loop Depth	47
Definition of the Cable Arrangement and Cable Trolley Selection	48
Cable Factors	48

System Arrangement Program 0240

Rails and Mounting Parts

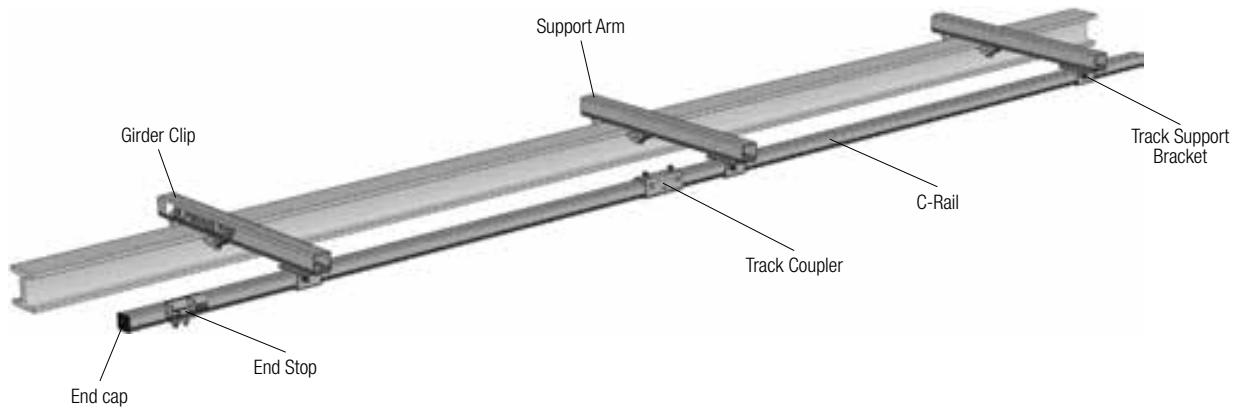

Festoon Systems for Flat Cables

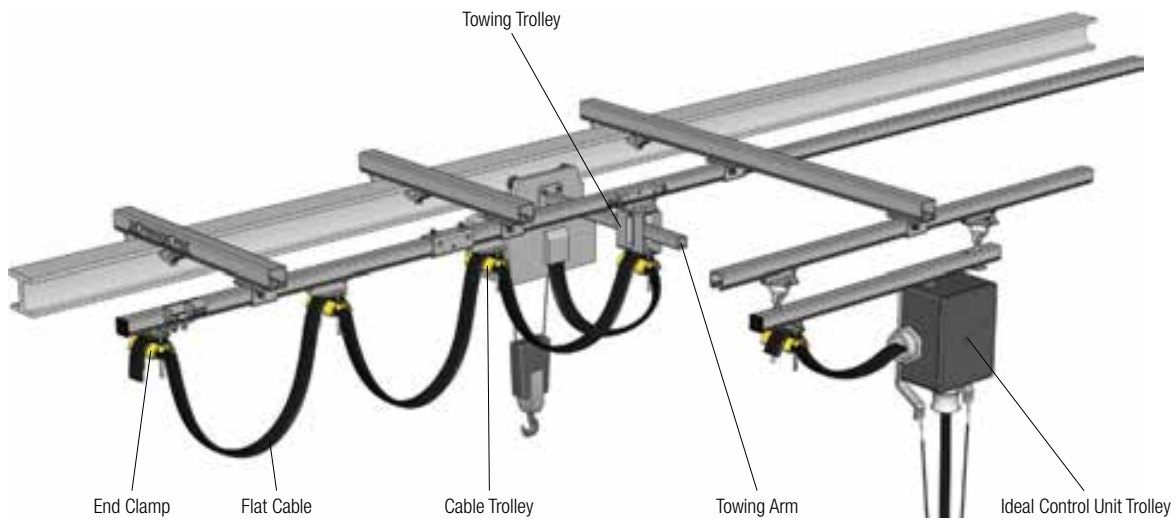

Festoon Systems for Round Cable

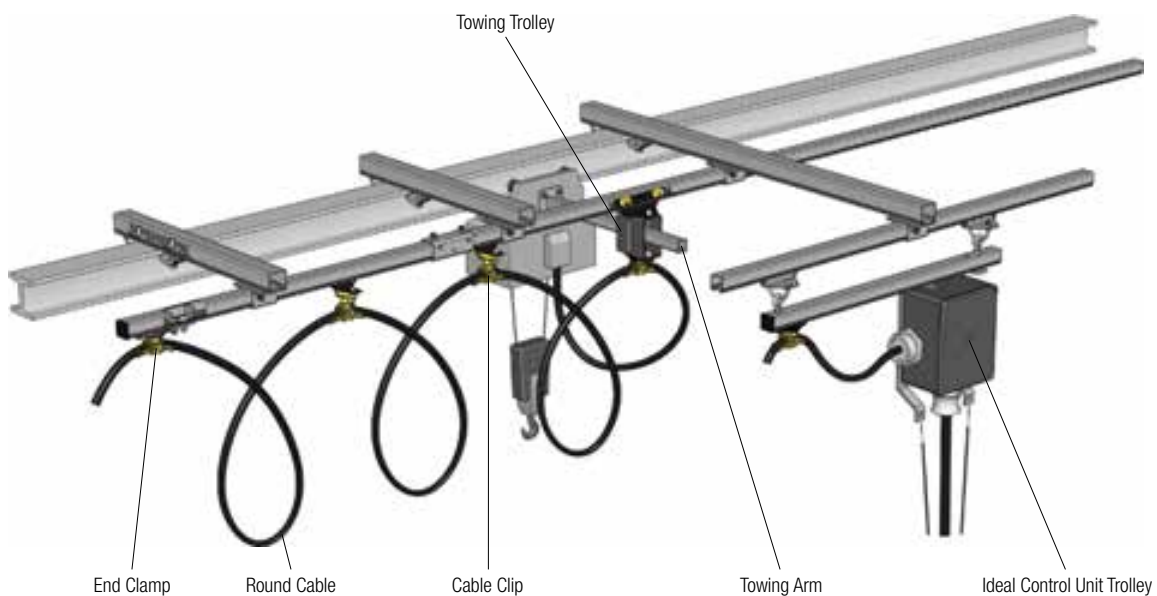

C-Rails and Accessories

Program 0240

C-Rails

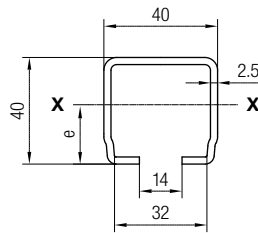

Order No.	Material	Length [mm]	Thickness s [mm]	I_x [cm ⁴]	Static Values		Weight [kg/m]
					W_x [cm ³]	e [mm]	
024100-6	sendzimir galvanized steel	6000	2.5	6.74	3.08	21.6	2.5
024100-4		4000					
024109-6	stainless steel V4A 1.4571	6000	2.5	6.74	3.08	21.6	2.5
024109-4		4000					

Other lengths or stainless steel V2A (1.4301) on request

90°- Curves

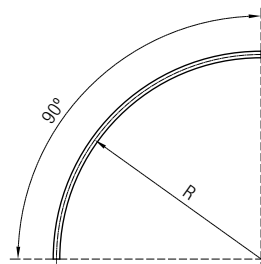

Order No.	Material	R	Developed Length [mm]	Loop Depth max. 0.35 x R [mm]	for max. Trolley Length [mm]	Weight [kg]
		[mm]				
024102-01000	sendzimir galvanized steel	1000	1570	350	160	3.9
024102-01200		1200	1885	420	160	4.7
024102-01400		1400	2200	490	200	5.5
024102-01600		1600	2510	560	200	6.3
024102-01800		1800	2830	630	280	7.1
024102-02000		2000	3140	700	280	7.9
024115-01000	stainless steel V4A 1.4571	1000	1570	350	160	3.9
024115-01200		1200	1885	420	160	4.7
024115-01400		1400	2200	490	200	5.5
024115-01600		1600	2510	560	200	6.3
024115-01800		1800	2830	630	280	7.1
024115-02000		2000	3140	700	280	7.9

Other curves or stainless steel V2A (1.4301) on request

C-Rails and Accessories Program 0240

Track Couplers

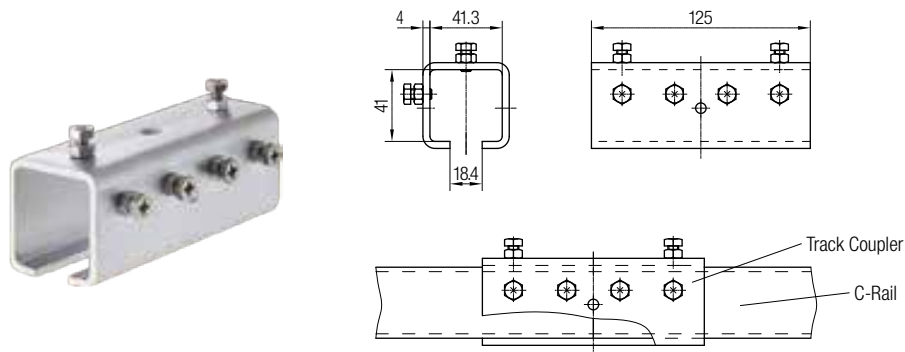

Order No.	Material	Weight [kg]
024105	galvanized steel	0.610
024186	stainless steel V4A	0.610

Note

A track coupler must be provided at each track joint.

Track Couplers, Two-Piece

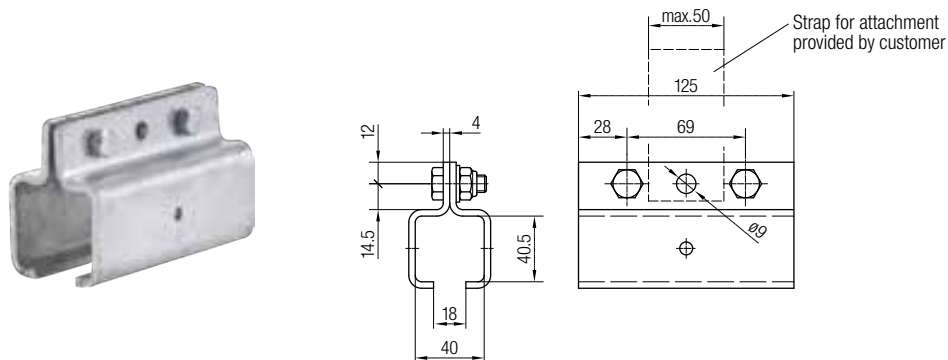

Order No.	Material	Weight [kg]
024106	galvanized steel	0.790
024188	stainless steel V4A	0.790

C-Rails and Accessories

Program 0240

Track Support Bracket, One-Piece, for Ceiling Attachment

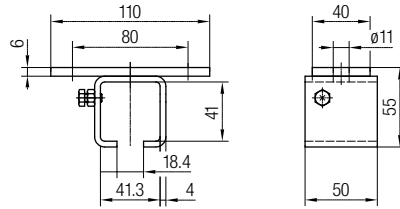

Order No.	Material	Perm. Load [kg]	Weight [kg]
024121	galvanized steel	250	0.360
024191	stainless steel V4A	250	0.360

Track Support Bracket, One-Piece, with Square Nut for Attachment to Support Arms

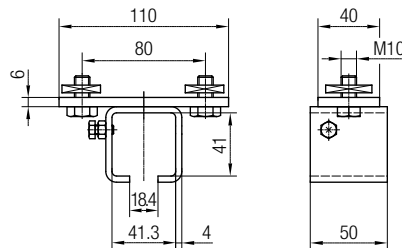

Order No.	Material	Suitable for support arm type	Perm. Load [kg]	Weight [kg]
024122	galvanized steel	020186, 020276	250	0.450
024192	stainless steel V4A	020485, 020488	250	0.450

Track Support Bracket, One-Piece, for Attachment to Existing Steel Structure

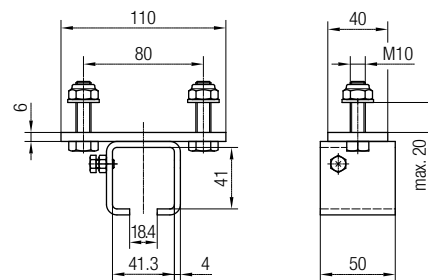

Order No.	Material	Perm. Load [kg]	Weight [kg]
024123	galvanized steel	250	0.470
024193	stainless steel V4A	250	0.470

C-Rails and Accessories

Program 0240

Track Support Brackets, Three-Piece, for Ceiling Attachment

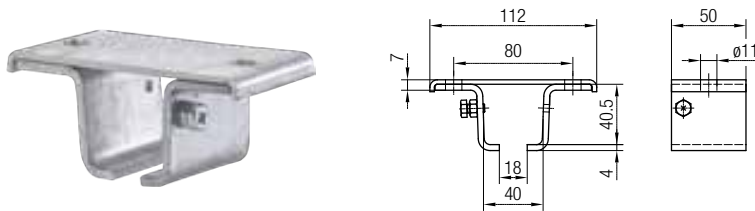

Order No.	Type	Material	Perm. Load [kg]	Weight [kg]
024152	without locking screw	galvanized steel	100	0.350
024153	with locking screw			0.360
024172	without locking screw	stainless steel V4A	100	0.350
024173	with locking screw			0.360

Track Support Brackets, Three-Piece, with Square Nut for Attachment to Support Arms

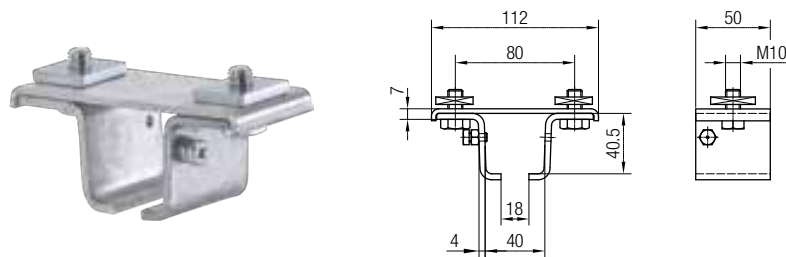

Order No.	Type	Material	Suitable for Support Arm Type	Perm. Load [kg]	Weight [kg]
024154	without locking screw	galvanized steel	020186, 020276	100	0.440
024155	with locking screw				0.450
024174	without locking screw	stainless steel V4A	020485, 020488	100	0.440
024175	with locking screw				0.450

Track Support Brackets, Three-Piece, for Attachment to the Existing Steel Structure

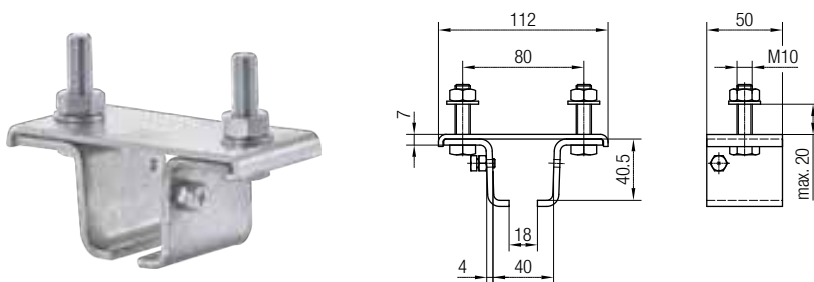

Order No.	Type	Material	Perm. Load [kg]	Weight [kg]
024156	without locking screw	galvanized steel	100	0.460
024157	with locking screw			0.470
024176	without locking screw	stainless steel V4A	100	0.460
024177	with locking screw			0.470

C-Rails and Accessories Program 0240

Track Support Bracket for Attachment to the Existing Steel Structure

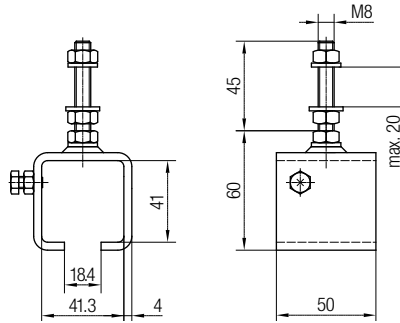

Order No. 024125

- Material: galvanized steel
- Perm. Load: 100 kg
- Weight: 0.320 kg

Track Support Bracket and Coupler, One-Piece, for Ceiling Attachment

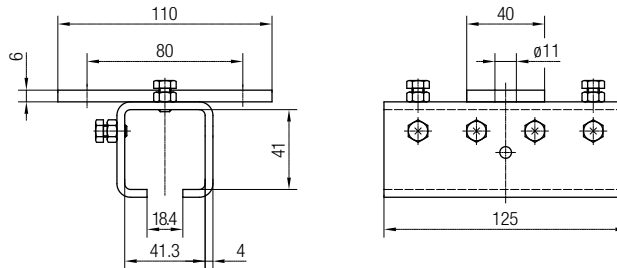

Order No. 024141

- Material: galvanized steel
- Perm. Load: 250 kg
- Weight: 0.660 kg

Track Support Bracket and Coupler, One-Piece with Square Nut for Attachment to Support Arms

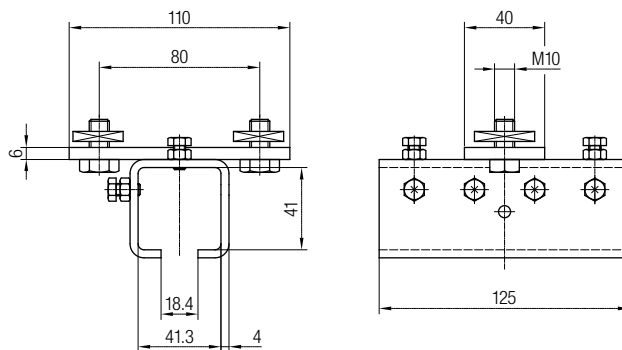

Order No. 024142

- Material: galvanized steel
- Perm. Load: 250 kg
- Suitable for support arm type: 020186 and 020276
- Weight: 0.750 kg

Track Support Bracket and Coupler, One-Piece for Attachment to the Existing Steel Structure

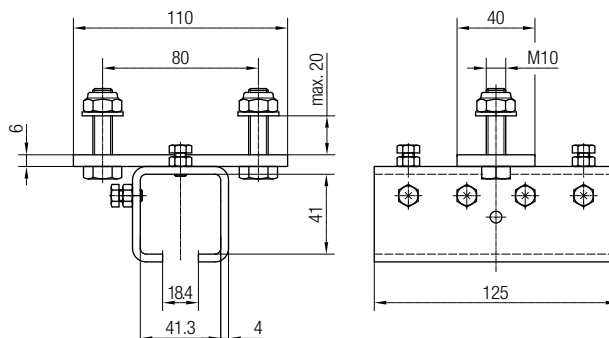

Order No. 024143

- Material: galvanized steel
- Perm. Load: 250 kg
- Weight: 0.770 kg

C-Rails and Accessories Program 0240

Track Support Brackets for Attachment to the Existing Steel Structure

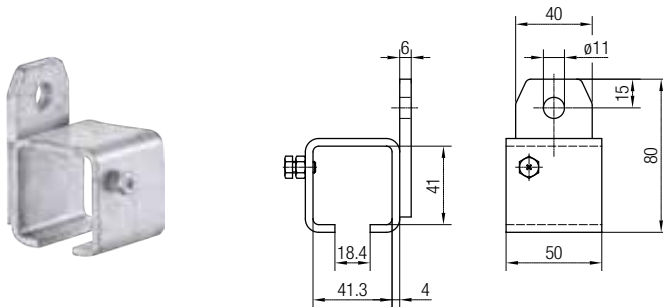

Order No.	Material	Perm. Load [kg]	Weight [kg]
024130	galvanized steel	100	0.320
024182	stainless steel V4A	100	0.320

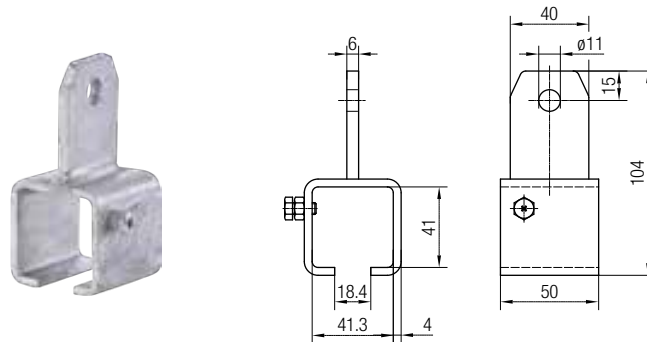

Order No.	Material	Perm. Load [kg]	Weight [kg]
024131	galvanized steel	250	0.300
024197	stainless steel V4A	250	0.300

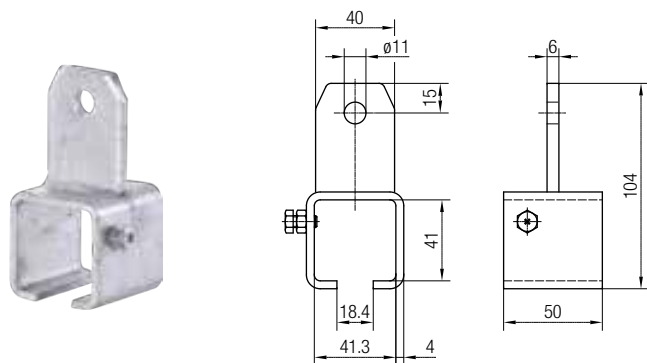

Order No.	Material	Perm. Load [kg]	Weight [kg]
024132	galvanized steel	250	0.300
024198	stainless steel V4A	250	0.300

C-Rails and Accessories Program 0240

Track Support Bracket, bare to weld on

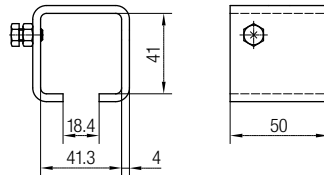

- Order No. 024120**
- Material: bare steel
 - Weight: 0.220 kg

Track Support Bracket and Coupler, bare to weld on

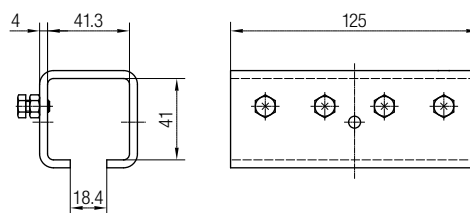

- Order No. 024140**
- Material: bare steel
 - Weight: 0.600 kg

Track Support Bracket for Direct Attachment below I-Beams

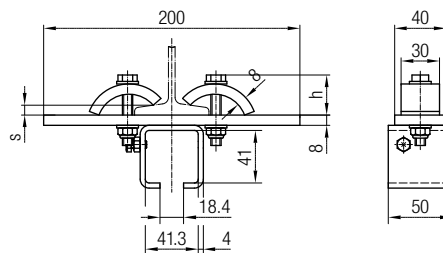

- Order No. 024124**
- Material: galvanized steel
 - Perm. Load: 160 kg
 - for flange widths 40 - 103 mm
 - Weight: 0.800 kg

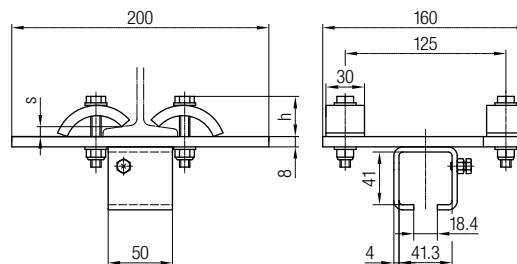

- Order No. 024128**
- Material: galvanized steel
 - Perm. Load: 250 kg
 - for flange widths 40 - 103 mm
 - Weight: 2.820 kg

Flange Thickness s [mm]	4	6	8	10	12	16	20
-------------------------	---	---	---	----	----	----	----

Mounting Height h [mm]	31	32	33	34	35	37	40
------------------------	----	----	----	----	----	----	----

Bolt Complete

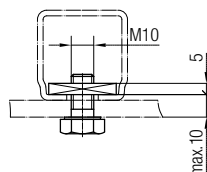

Order No.	Packing Unit [St.]	Material	Weight [kg]
020176-10x20P	20	galvanized steel	0.900
020476-10x20P	20	stainless steel V4A	0.900

Design in stainless steel V4A

C-Rails and Accessories

Program 0240

Support Arms 40 x 40 x 2.5 - punched

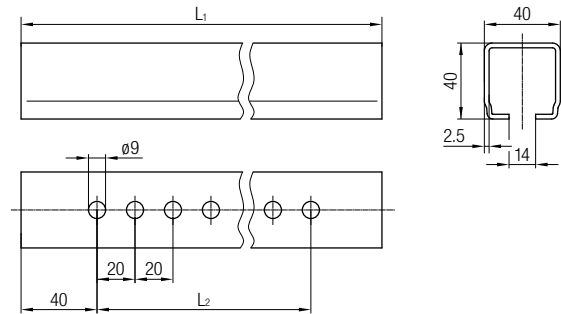

Order No.	L ₁ [mm]	L ₂ [mm]	Material	Weight [kg]
020186-0250	250	200	sendzimir galvanized steel	0.625
020186-0315	315	260		0.785
020186-0400	400	340		1.000
020186-0500	500	340		1.250
020186-0630	630	340		1.575
020186-0800	800	340		2.000
020186-1000	1000	340		2.500
020186-1250	1250	340		3.125
020488-0400	400	340	stainless steel V4A 1.4571	1.000
020488-0500	500	340		1.250
020488-0630	630	340		1.575
020488-0800	800	340		2.000
020488-1000	1000	340		2.500
020488-1250	1250	340		3.125

Support Arms 40 x 40 x 2.5 - unpunched

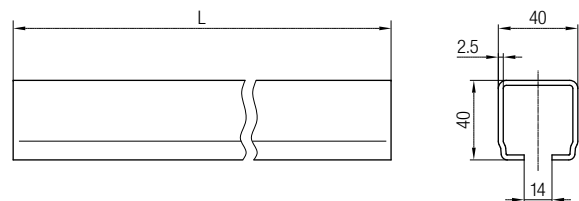

Order No.	L [mm]	Material	Weight [kg]
020276-0315	315	sendzimir galvanized steel	0.785
020276-0450	450		1.125
020276-0550	550		1.375
020276-0650	650		1.625
020276-0840	840		2.100
020276-0950	950		2.375
020276-1000	1000		2.500
020276-1150	1150		2.875
020276-1340	1340		3.350
020276-1520	1520		3.800
020276-1800	1800		4.500
020276-2000	2000		5.000

C-Rails and Accessories Program 0240

Permissible Load for Support Arms

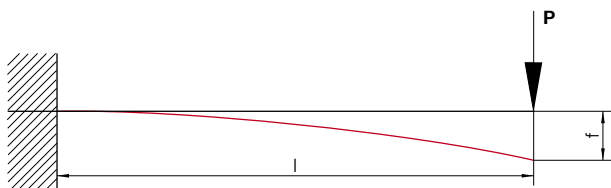

Note

- calculated with $\sigma = 140 \text{ N/mm}^2$ tension
- f = appropriate max. resulting deflection

		l [m]								
		0.25	0.40	0.50	0.65	0.80	1.00	1.25	1.52	2.00
Support Arm 40x40x2.5	P [kg]	164.5	103.0	82.0	63.0	51.5	41.0	33.0	27.0	20.5
	f [cm]	0.07	0.20	0.30	0.45	0.70	1.10	1.70	2.50	4.30

Bracket for Support Arms 40x40x2.5 to be bolted with 2-Hole Connecting Plate

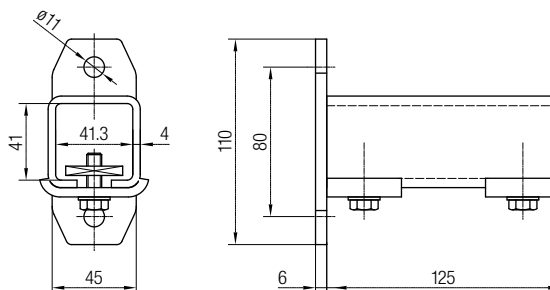

Order No.	Material	Suitable for Support Arm	Weight [kg]
020282	galvanized steel	020186, 020276	1.000

Bracket for Support Arms 40x40x2.5 to be bolted with 4-Hole Connecting Plate

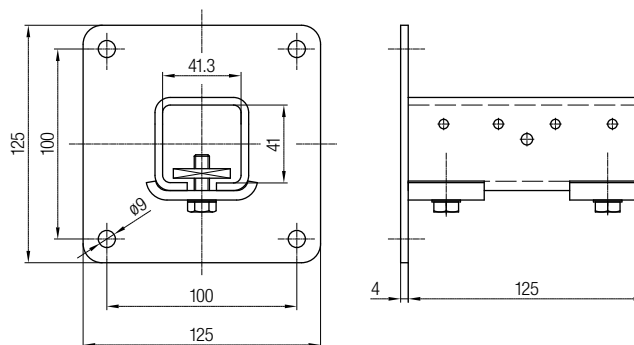

Order No.	Material	Suitable for Support Arm	Weight [kg]
020284	galvanized steel	020186, 020276	1.300

C-Rails and Accessories

Program 0240

Console Brackets to be bolted with 4-Hole Connecting Plate

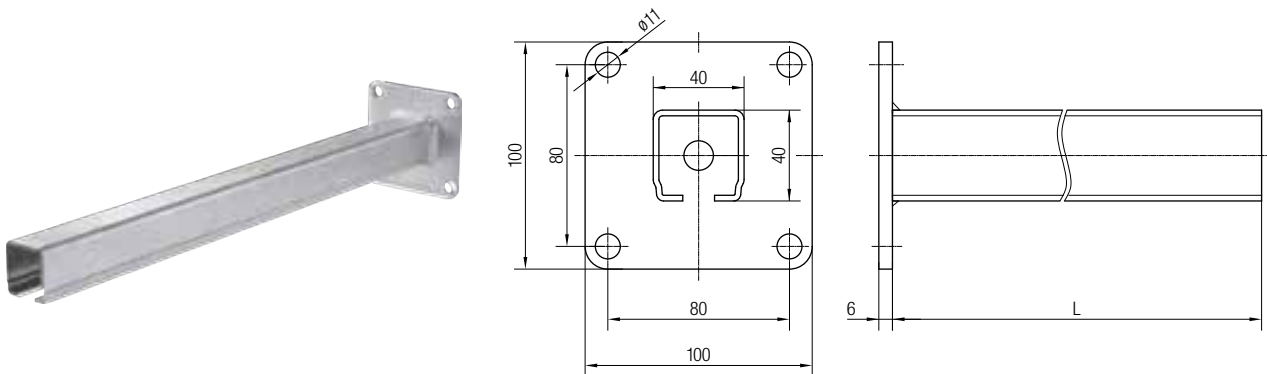

Order No.	Material	L [mm]	Weight [kg]
020206-0500	galvanized steel	500	1.700
020206-0630		630	2.000
020206-0800		800	2.450
020206-1000		1000	2.800

Brackets, bare to be welded

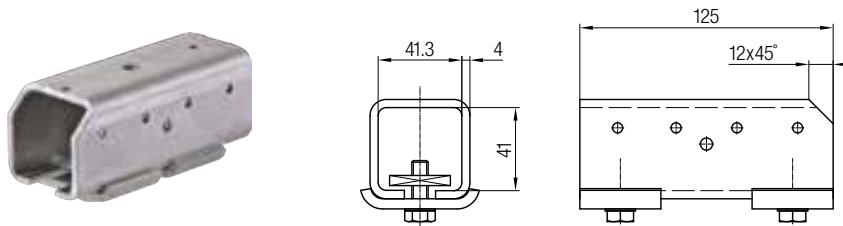

Order No.	Bracket	Material	Suitable for Support Arm	Weight [kg]
		Fasteners		
020286	bare steel	galvanized steel	020186, 020276	0.730

C-Rails and Accessories Program 0240

Girder Clips, Clamping Thickness 4 - 20 mm

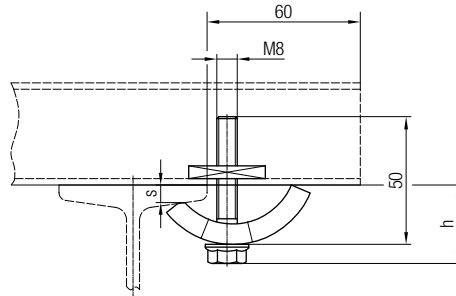

Order No.	Material	Weight [kg]
020180-08	galvanized steel	0.150
020480-08	stainless steel V4A	0.150

Clamping Thickness s [mm]	4	6	8	10	12	16	20
Mounting Height h [mm]	31	32	33	34	35	37	40

Girder Clips, Clamping Thickness 18 - 36 mm

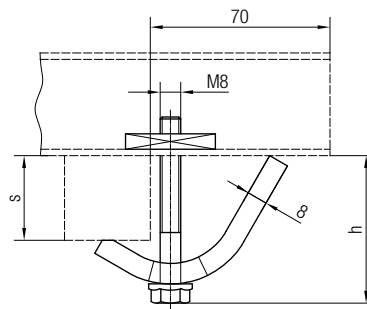

Order No.	Material	Weight [kg]
020180-08x36	galvanized steel	0.220
020480-08x36	stainless steel V4A	0.220

Clamping Thickness s [mm]	18-20	20-24	24-28	28-32	32-36
Mounting Height h [mm]	42-44	44-48	48-52	52-56	56-60

Girder Clips, Twist-Secured, Clamping Thickness 6 - 25 mm

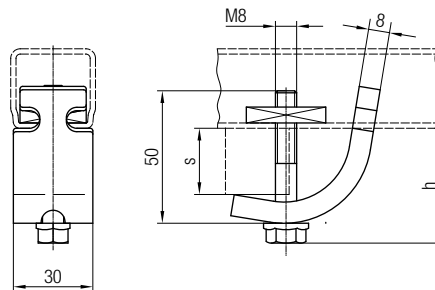

Order No.	Material	Weight [kg]
020181-08	galvanized steel	0.190

Clamping Thickness s [mm]	6 - 25
Mounting Height h [mm]	32 - 40

Design in stainless steel V4A

C-Rails and Accessories

Program 0240

Girder Clips, Reinforced Type, Clamping Thickness 6 - 21 mm

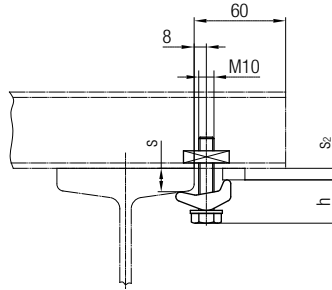

Order No.	Material	Weight [kg]
020180-10	galvanized steel	0.170

Clamping Thickness s [mm]	6 - 14	11 - 16	16 - 21
Mounting Height h [mm]	35 - 41	41 - 46	46 - 51
Clamping Piece ¹⁾ s_2 [mm]	-	5	10

¹⁾ is not included with the girder clips

Girder Clips, Reinforced Type, Clamping Thickness 6 - 30 mm

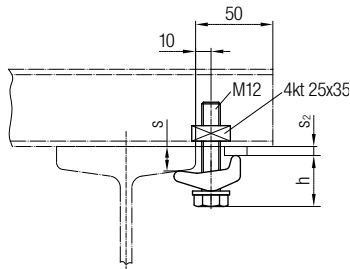

Order No.	Material	Weight [kg]
020180-12	galvanized steel	0.220

Clamping Thickness s [mm]	6 - 14	14 - 22	22 - 30
Mounting Height h [mm]	39 - 47	47 - 55	55 - 63
Clamping Piece ¹⁾ s_2 [mm]	-	8	16

¹⁾ is not included with the girder clips

C-Rails and Accessories Program 0240

Application Examples for Support Arm and C-Rail Fastening with Support Arms – unpunched

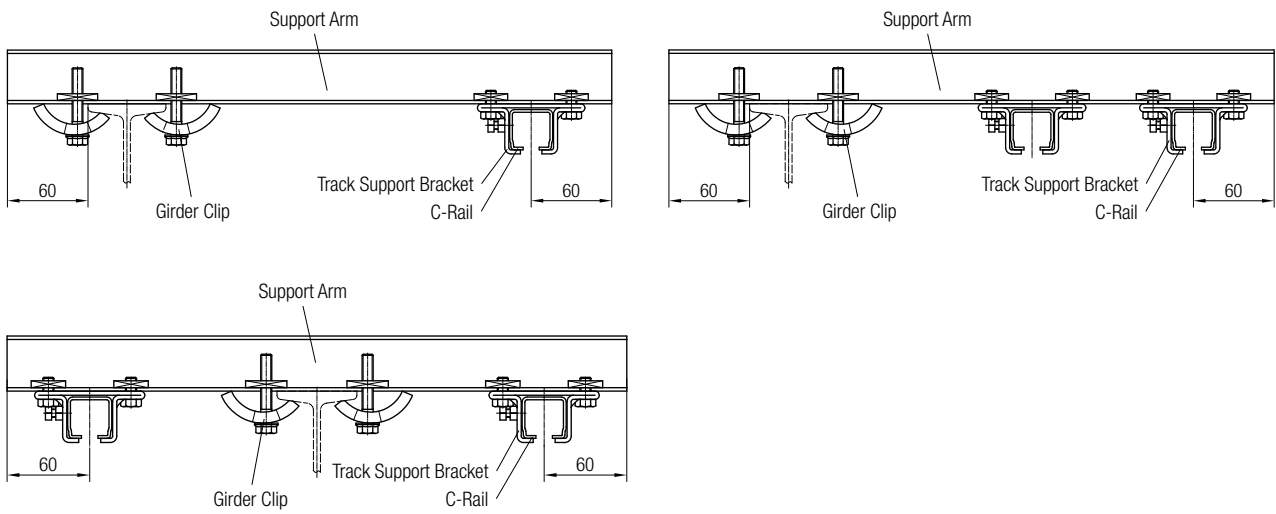

Application Examples for Support Arm and C-Rail Fastening with Support Arms – punched

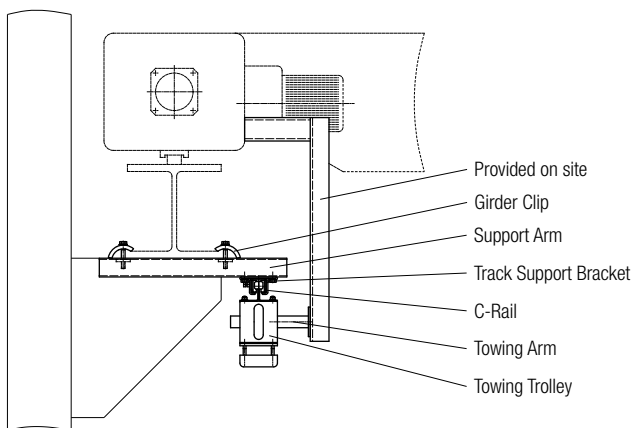

Application Example for Support Arm and C-Rail Fastening with Welded Brackets

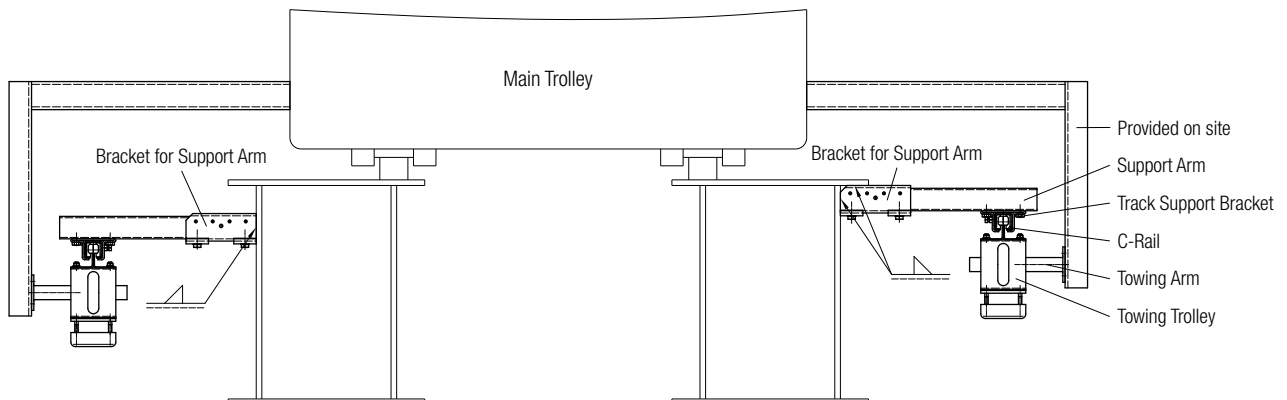

C-Rails and Accessories Program 0240

End Stop with Rubber Buffer

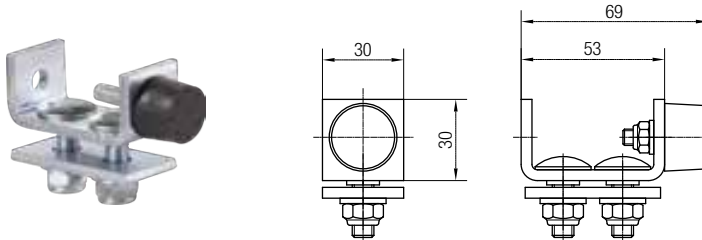

Order No.	Material	Weight [kg]
024111	galvanized steel; rubber buffer	0.190
024181	stainless steel V4A	0.190

End Stop without Rubber Buffer

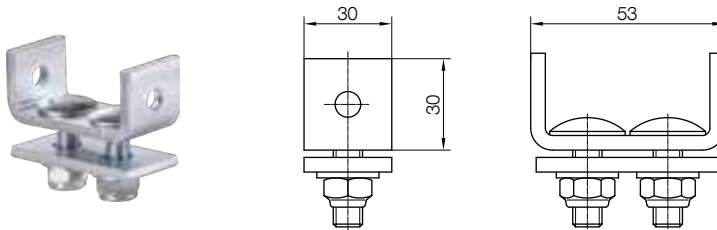

Order No.	Material	Weight [kg]
024110	galvanized steel	0.160
024180	stainless steel V4A	0.160

Application Example for End Stop Assembly

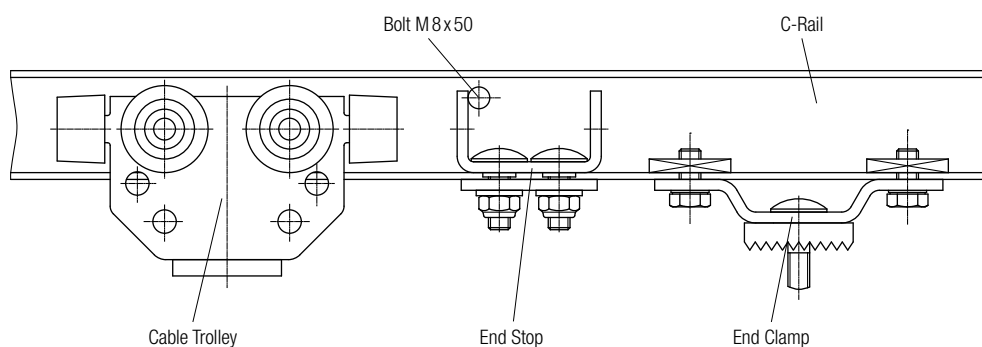

Note

The end stop is fixed in the C-rail between the end clamp and the cable trolley. This helps to prevent cable trolleys running into the end clamp. For control supply systems with manually driven ideal control trolleys an end stop mounted at the end of the C-rail prevents the ideal control trolley from travelling out of the rail.

C-Rails and Accessories Program 0240

Towing Arms

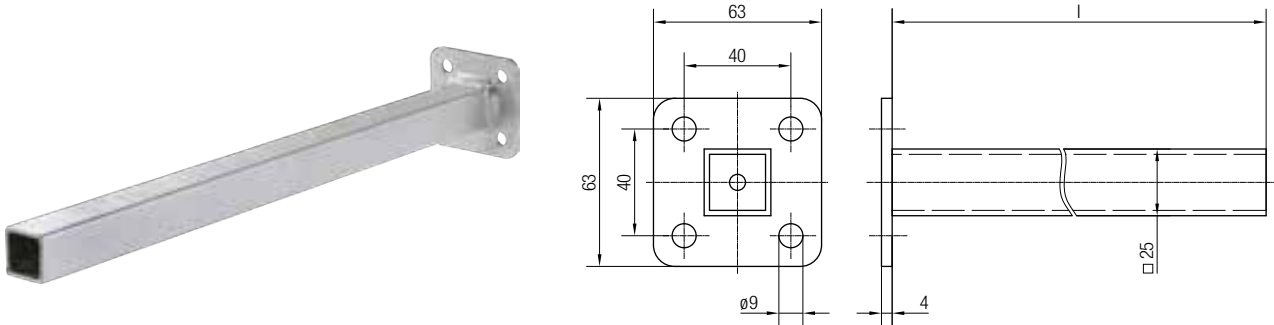

Order No.	Material	l [mm]	Weight [kg]
020195-400	galvanized steel	400	0.600
020195-630		630	1.000
020495-400	stainless steel V4A	400	0.600
020495-630		630	1.000

End Caps

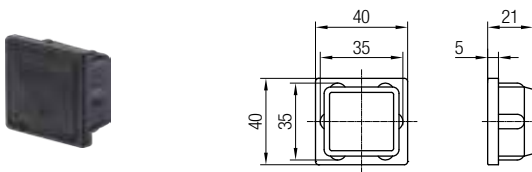

Order No. 020662-40

- Material: plastic
- Weight: 0.008 kg

C-Rails and Accessories Program 0240

CI-Rail Reinforced Type, Wall Thickness 3.0 mm

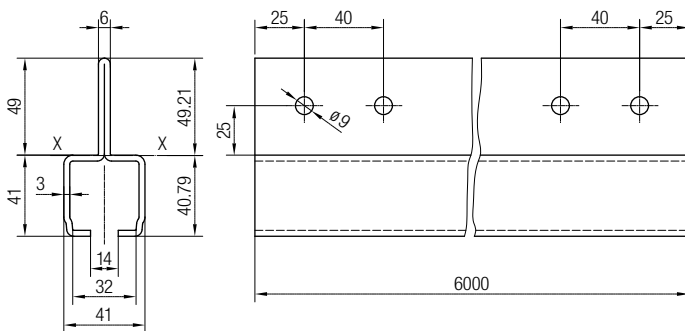

Order No. 024052-6

- Static values:
 - $I_x = 44.20 \text{ cm}^4$
 - $W_x = 8.981 \text{ cm}^3$
- Material: sendzimir, galvanized steel
- Weight: 5.300 kg/m

Track Coupler

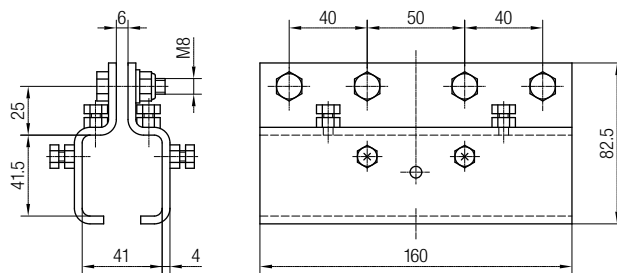

Order No. 024062

- Material: galvanized steel
- Weight: 1.090 kg

Track Support Bracket

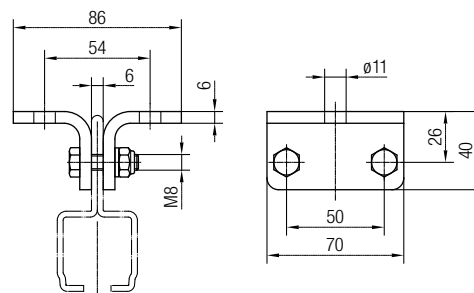

Order No. 024070

- Material: galvanized steel
- Weight: 0.700 kg

1) 2 holes ø 8.4 mm spaced at 50 mm to be drilled in CI-rail

C-Rails and Accessories

Program 0240

CV-Rail Reinforced Type, Wall Thickness 3.0 mm

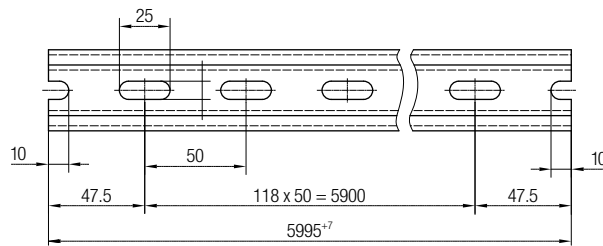
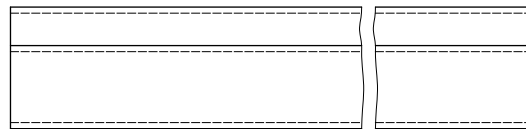
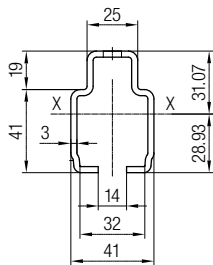

Order No. 024030-6

- Static values:
 - $I_x = 16.816 \text{ cm}^4$
 - $W_x = 5.412 \text{ cm}^3$
- Material: galvanized steel
- Weight: 3.646 kg/m

Note

Type with wall thickness 2.5 mm on request.

Track Coupler

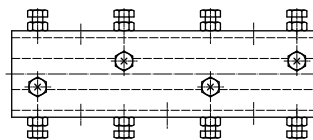
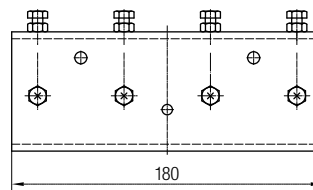
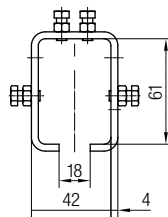

Order No. 024040

- Material: galvanized steel
- Weight: 1.230 kg

Cable Trolleys for Flat Cables Program 0240

Steel Cable Trolley with Plastic Cable Support

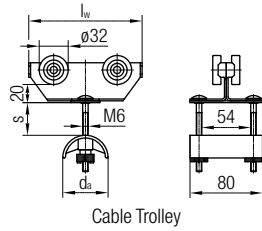

Cable Trolley

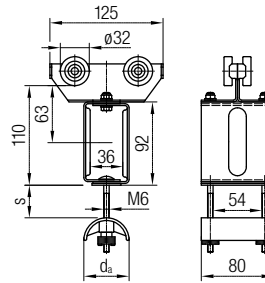

Towing Trolley

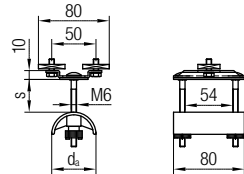

End Clamp

Technical details

- Trolley body: galvanized steel
- Cable supports: plastic
- Hardware: galvanized steel
- Standard rollers: ball bearings, galvanized with ZZ-sealing
- Temperature range: -30°C to +80°C

Cable Trolley Order No.	[kg]	Towing Trolley Order No.	[kg]	End Clamp Order No.	[kg]	d_a	l_w	s	Max. Load Capacity [kg]	Max. Travel Speed [m/min]	Roller Type
						[mm]	[mm]	[mm]			
024246	0.300	024256	0.625	023269	0.185	50	80	15	12.5	40	1
024240-80	0.375	024250	0.700	023269	0.185	50	80	15	20.0	50	2
024240	0.460	024250	0.700	023269	0.185	50	125	36			
024241	0.485	024251	0.745	023279	0.220	80	125	22			

1) Plastic roller and bronze friction bearing 2) Ball bearing, galvanized (ZZ)

Note

For a better sealing the standard rollers (ZZ) can also be provided with a 2 RS-sealing.
The order-no. has to be completed with the variation designation .../010.

Cable Trolleys for Flat Cables Program 0240

Steel Cable Trolleys, Light Series without Buffer

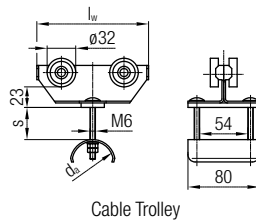

Cable Trolley

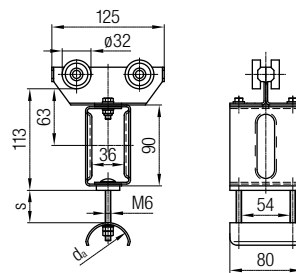

Towing Trolley

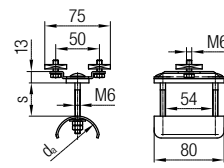

End Clamp

Technical details

- Trolley body: galvanized steel
- Hardware: galvanized steel
- Standard rollers: ball bearings, galvanized with ZZ-sealing
- Temperature range: -30°C to +80°C
- Stainless steel rollers: ball bearing, V4A with 2RS-sealing
- Temperature range stainless steel: -10°C to +80°C

Cable Trolley Order No.	[kg]	Towing Trolley Order No.	[kg]	End Clamp Order No.	[kg]	d _a	l _w	s	Max. Load Capacity [kg]	Max. Travel Speed [m/min]
024244-080	0.460	024254	0.790	023569	0.270	50	80	15	25	50
024244-125	0.550	024254	0.790	023569	0.270	50	125	36		
024245	0.630	024255	0.890	023579	0.370	80	125	22		
024850-080	0.460	024855	0.790	023438	0.270	50	80	15	12.5	50
024850-125	0.550	024855	0.790	023438	0.270	50	125	36		
024851	0.630	024856	0.890	023439	0.370	80	125	22		

Steel Cable Trolleys, Light Series with Buffer

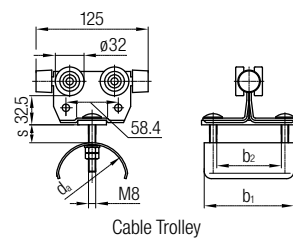

Cable Trolley

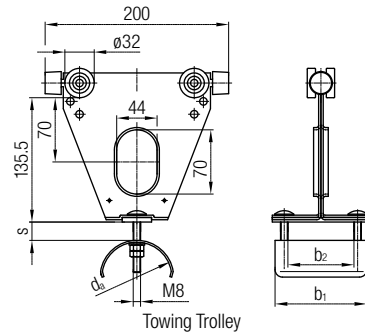

Towing Trolley

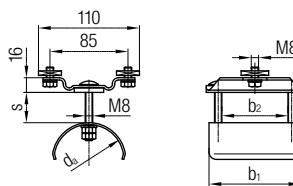

End Clamp

Technical details

- Trolley body and cable supports: galvanized steel
- Hardware: galvanized steel
- Standard rollers: ball bearings, galvanized with ZZ-sealing
- Temperature range: -30°C to +80°C

Cable Trolley Order No.	[kg]	Towing Trolley Order No.	[kg]	End Clamp Order No.	[kg]	d _a	b ₁	b ₂	s	Max. Load Capacity [kg]	Max. Travel Speed [m/min]
024269-125x100	0.705	024279-200x100	0.905	024289-100x038	0.370	50	100	72	35	28	63
024270-125x100	0.775	024280-200x100	0.975	024290-100x038	0.440	80		20			
024269-125x160	0.970	024279-200x160	1.170	024289-160x038	0.635	50	160	132	35		
024270-125x160	1.040	024280-200x160	1.240	024290-160x038	0.690	80		20			

Note

For a better sealing the standard rollers (ZZ) can also be provided with a 2 RS-sealing. The order-no. has to be completed with the variation designation .../010.

Cable Trolleys for Flat Cables Program 0240

Steel Cable Trolleys, Heavy Series

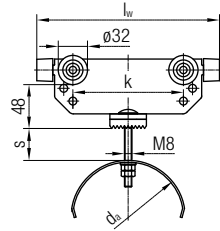

Cable Trolley

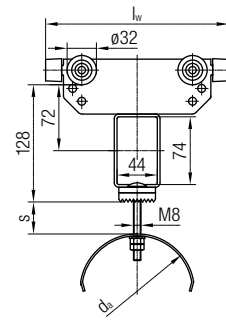
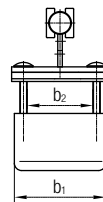

Towing Trolley

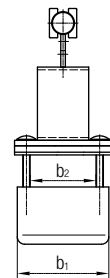

Technical details

- Trolley body and cable supports: galvanized steel
- Hardware: galvanized steel
- Standard rollers: ball bearing, galvanized with ZZ-sealing
- Temperature range: -30°C to +80°C
- Stainless steel rollers: ball bearing, V4A with 2 RS-sealing
- Temperature range stainless steel: -10°C to +80°C

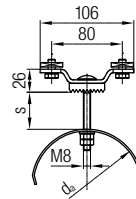

End Clamp

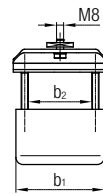

Cable Trolley Order No.	[kg]	Towing Trolley Order No.	[kg]	End Clamp Order No.	[kg]	d _a [mm]	l _{w1} ¹⁾ [mm]	l _{w2} ²⁾ [mm]	b ₁ [mm]	b ₂ [mm]	s [mm]	k [mm]	Max. Load Capacity [kg]	Max. Travel Speed [m/min]
024210-100x100	0.83	024220-200x100	1.65	024230-100x062	0.70	80	100	-	100	72	10	46	32	80 (100)
024210-125x100	0.85	024220-200x100	1.65	024230-100x062	0.70		-	125	100	72	20			
024210-125x160	1.09	024220-200x160	2.09	024230-160x062	0.94		-	125	160	132	20	81	32	80 (100)
024210-135x100	0.91	024220-200x100	1.65	024230-100x062	0.70		135	-	100	72	27			
024210-160x100	0.93	024220-200x100	1.65	024230-100x062	0.70		-	160	100	72	38	121	32	80 (100)
024210-160x160	1.17	024220-200x160	2.09	024230-160x062	0.94		-	160	160	132	38			
024210-200x100	1.05	024220-200x100	1.65	024230-100x062	0.70		-	200	100	72	58	121	32	80 (100)
024210-200x160	1.29	024220-200x160	2.09	024230-160x062	0.94		-	200	160	132	58			
024212-160x100	1.05	024222-200x100	1.75	024232-100x042	0.80	125	-	160	100	72	15	81	32	80 (100)
024212-160x160	1.38	024222-200x160	2.28	024232-160x042	1.13		-	160	160	132	15			
024212-200x100	1.15	024222-200x100	1.75	024232-100x042	0.80		-	200	100	72	35	121	32	80 (100)
024212-200x160	1.48	024222-200x160	2.28	024232-160x042	1.13		-	200	160	132	35			
024212-250x100	1.39	024222-250x100	1.99	024232-100x062	0.82		-	250	100	72	60	171	32	80 (100)
024212-250x160	1.72	024222-250x160	2.52	024232-160x062	1.15		-	250	160	132	60			
024213-200x100	1.30	024223-200x100	1.90	024233-100x042	1.00		-	200	115	72	18	121	32	80 (100)
024213-200x160	1.72	024223-200x160	2.52	024233-160x042	1.40		-	200	175	132	18			
024213-250x100	1.40	024223-250x100	2.00	024233-100x042	11.0	160	-	250	115	72	42	171	32	80 (100)
024213-250x160	1.82	024223-250x160	2.62	024233-160x042	1.40		-	250	175	132	42			
024213-250x200	2.21	024223-250x200	3.01	024233-200x042	1.85		-	250	215	172	42	171	32	80 (100)
024214-250x160	2.07	024224-250x160	2.87	024234-160x042	1.65		-	250	175	132	22			
024214-320x200	2.76	024224-320x200	3.56	024234-200x062	2.22	200	-	320	215	172	58	241	32	80 (100)
024810-125x100	0.85	024820-200x100	1.65	024830-100x062	0.70	80	-	125	100	72	20	46	16	80
024810-200x100	1.05	024820-200x100	1.65	024830-100x062	0.70		-	200	100	72	58			
024812-160x100	1.05	024822-200x100	1.75	024832-100x042	0.80	125	-	160	100	72	15	81	16	80
024812-250x100	1.39	024822-250x100	1.99	024832-100x062	0.82		-	250	100	72	60			
024812-250x160	1.72	024822-250x160	2.52	024832-160x062	1.15		-	250	160	132	60	171	16	80
024913-200x100	1.28	024923-200x100	1.88	024933-100x042	0.98		-	200	100	72	18			
024913-250x160	1.86	024923-250x160	2.66	024933-160x042	1.44	160	-	250	160	132	42	171	16	80
024814-280x160	2.17	024824-280x160	2.97	024834-160x042	1.65	200	-	280	175	132	38	201	16	80

1) without buffer 2) with buffer

Note

For a better sealing the standard rollers (ZZ) can also be provided with a 2 RS-sealing.
The order-no. has to be completed with the variation designation .../010.
For high speeds up to 100 m/min and/or silent running rollers with polyurethane bandage can be used.
The order-no. has to be completed with the variation designation .../017.

Cable Trolleys for Round Cables Program 0240

Steel Cable Trolleys with Ball Joint for Cable Clips 020131, Light Series without Buffer

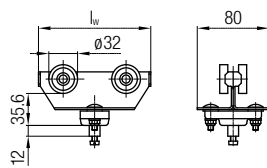

Cable Trolley

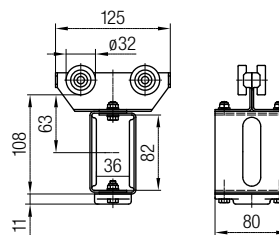

Towing Trolley

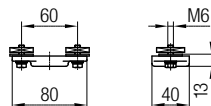

End Clamp

Technical details

- Trolley body: galvanized steel
- Ball joint: plastic
- Hardware: galvanized steel
- Standard rollers: ball bearings, galvanized with ZZ-sealing
- Temperature range: -30°C to +60°C
- Stainless steel rollers: ball bearings, V4A with 2RS-sealing
- Temperature range stainless steel: -10°C to +60°C

Cable Trolley Order No.	[kg]	l _w [mm]	Towing Trolley Order No.	[kg]	End Clamp Order No.	[kg]	Max. Load Capacity [kg]	Max. Travel Speed [m/min]
024313-80	0.36	80	024314	0.67	024312	0.15	20	50
024313	0.45	125						
024860-080	0.36	80	024861	0.67	024862	0.15	16	50
024860-125	0.45	125						

Steel Cable Trolleys with Ball Joint for Cable 020131, Heavy Series with Buffer

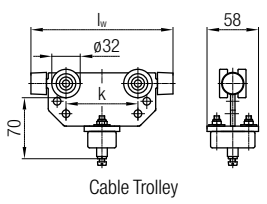

Cable Trolley

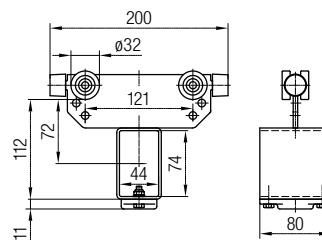

Towing Trolley

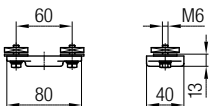

End Clamp

Technical details

- Trolley body: galvanized steel
- Ball joint: plastic
- Hardware: galvanized steel
- Standard rollers: ball bearings, galvanized with ZZ-sealing
- Temperature range: -30°C to +60°C
- Stainless steel rollers: ball bearings, V4A with 2RS-sealing
- Temperature range stainless steel: -10°C to +60°C

Cable Trolley Order No.	[kg]	l _w [mm]	k [mm]	Towing Trolley Order No.	[kg]	End Clamp Order No.	[kg]	Max. Load Capacity [kg]	Max. Travel Speed [m/min]
024310-125	0.54	125	46	024311	1.00	024312	0.15	20	63
024310-160	0.62	160	81						
024880-125	0.54	125	46	024881	1.00	024862	0.15	16	63

Notes

- For a better sealing the standard rollers (ZZ) can also be provided with a 2 RS-sealing. The order-no. has to be completed with the variation designation .../010.
- For max. 3 cables in separate cable clips, suspended one below the other
- Appropriate for cable clips:
020131-16, 020131-35, 020131-36 (only suited for trolley length ≥ 125 mm);
020431-16, 020431-35, 020431-36 (only suited for trolley length ≥ 125 mm)

Cable Trolleys for Round Cables Program 0240

Steel Cable Trolleys with Bracket for Cable Clips 020133, Heavy Series with Buffer

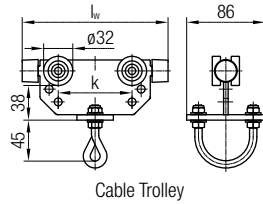

Cable Trolley

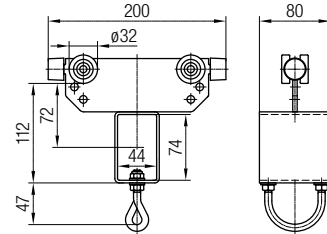

Towing Trolley

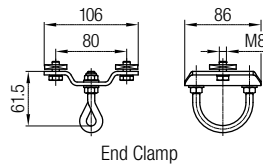

End Clamp

Technical details

- Trolley body and bracket: galvanized steel
- Hardware: galvanized steel
- Standard rollers: ball bearings, galvanized with ZZ-sealing
- Temperature range: -30°C to +80°C
- Stainless steel rollers: ball bearing, V4A with 2RS-sealing
- Temperature range stainless steel: -10°C to +80°C

Cable Trolley Order No.	[kg]	l _w [mm]	k [mm]	Towing Trolley		End Clamp		Max. Load Capacity [kg]	Max. Travel Speed [m/min]
				Order No.	[kg]	Order No.	[kg]		
024320-125	0.58	125	46	024321	1.00	024322	0.46	32	80
024320-160	0.66	160	81						
024320-200	0.76	200	121						
024885-125	0.58	125	46	024886	1.00	024887	0.46	16	80

Note

For a better sealing the standard rollers (ZZ) can also be provided with a 2 RS-sealing.
The order-no. has to be completed with the variation designation .../010.

Cable Trolleys for Round Cables Program 0240

Cable Clips for Fixation at the Ball Joint

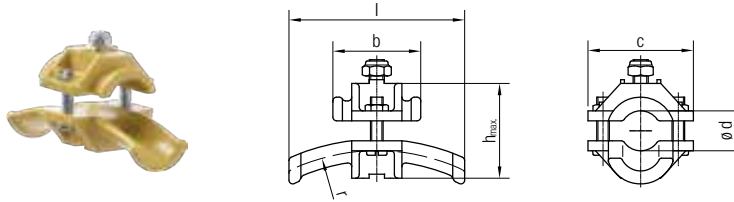

Order No.	for Cable- ϕ d [mm]	r [mm]	l [mm]	h [mm]	b [mm]	c [mm]	Material	Weight [kg]
020131-16	10 ... 16	80	70	38	35	42	plastic. hardware: galvanized steel	0.040
020131-25	17 ... 25	125	100	47	50	50		0.060
020131-36	26 ... 36	180	140	58	70	64		0.120
020431-16	10 ... 16	80	70	38	35	42	plastic, acid-resistant. hardware: stainless steel V4A	0.040
020431-25	17 ... 25	125	100	47	50	50		0.060
020431-36	26 ... 36	180	140	58	70	64		0.120

Cable Clips for Fixation at the Bracket

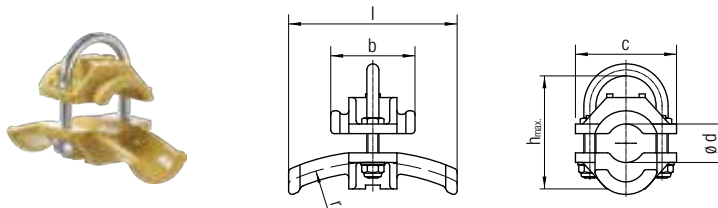

Order No.	for Cable- ϕ d [mm]	r [mm]	l [mm]	h [mm]	b [mm]	c [mm]	Material	Weight [kg]
020133-16	10 ... 16	80	70	38	35	42	plastic. hardware: galvanized steel	0.050
020133-25	17 ... 25	125	100	47	50	50		0.070
020133-36	26 ... 36	180	140	58	70	64		0.140
020133-50	37 ... 50	250	200	100	100	90	aluminum. hardware: galvanized steel	0.280
020133-63	51 ... 63	315	250	125	120	100		0.480
020433-16	10 ... 16	80	70	38	35	42	plastic, acid-resistant. hardware: stainless steel V4A	0.040
020433-25	17 ... 25	125	100	47	50	50		0.060
020433-36	26 ... 36	180	140	58	70	64		0.120

Additional Cable Clips for Combinations with Sizes 50 and 63 of Types 020133

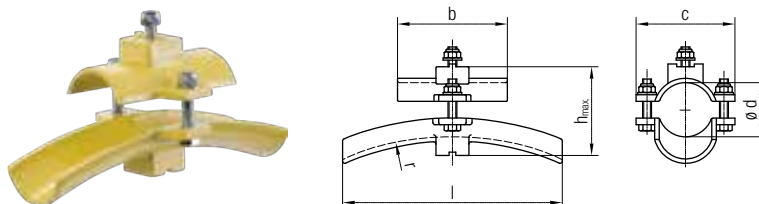

Order No.	for Cable- ϕ d [mm]	r [mm]	l [mm]	h [mm]	b [mm]	c [mm]	Material	Weight [kg]
020131-50	37 ... 50	250	200	80	100	90	aluminum, hardware: galvanized steel	0.260
020131-63	51 ... 63	315	250	105	125	100		0.460

Cable Trolleys for Round Cables Program 0240

Hose Clip for Fixation at the Ball Joint

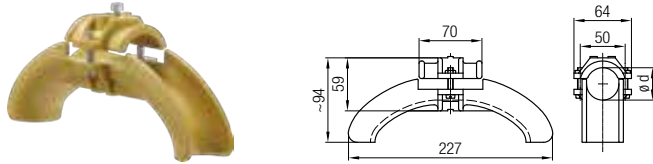

Order No.	Material	Hardware	for Hose- \varnothing d [mm]	Weight [kg]
020130-36	plastic	galvanized steel	26 - 36	0.130

Hose Clip for Fixation at the Bracket

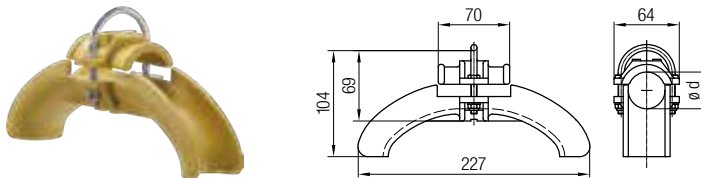

Order No.	Material	Hardware	for Hose- \varnothing d [mm]	Weight [kg]
020138-36	plastic	galvanized steel	26 - 36	0.150

Cable Trolleys for Round Cables Program 0240

Cable Trolley with Cable Clips, Heavy Series, Rotatable

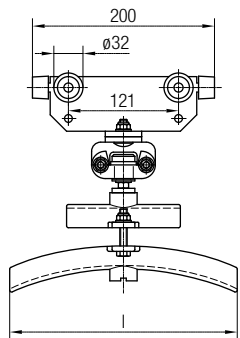

Cable Trolley

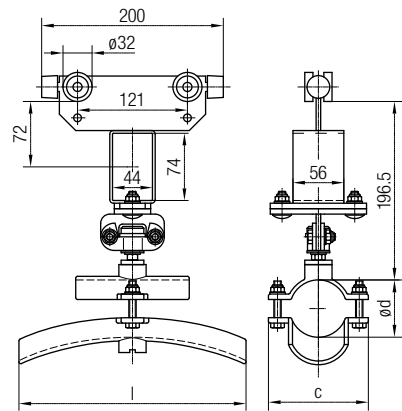

Towing Trolley

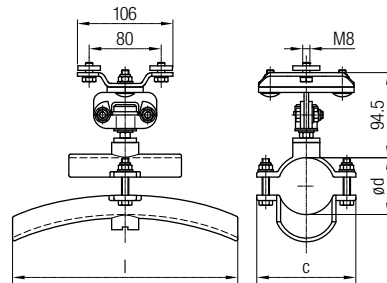

End Clamp

Technical details

- Trolley body and bracket: galvanized steel
 - Cable clips: aluminium
 - Hardware: galvanized steel
 - Standard rollers: ball bearings, galvanized with ZZ-sealing
 - Temperature range: -30°C to +80°C
 - For a better sealing the standard rollers (ZZ) can also be provided with a 2 RS-sealing
- The order-no. has to be completed with the variation designation .../010.

Cable Trolley Order No.	[kg]	l [mm]	ø d [mm]	c [mm]	Towing Trolley Order No.	[kg]	End Clamp Order No.	[kg]	Max. Load Capacity [kg]	Max. Travel Speed [m/min]
024528-200x050	1.54	200	37-50	90	024527-200x050	1.85	024529-050	1.20	32	80
024528-200x063	1.74	250	51-63	100	024527-200x063	2.15	024529-063	1.40		

Note

Can be combined with cable clips 020131-50 and 020131-63

Cable Trolleys for Round Cables Program 0240

Steel Cable Trolleys, Heavy Series
for Clamping of Round Cables with a max. Difference in Diameter of 6 mm

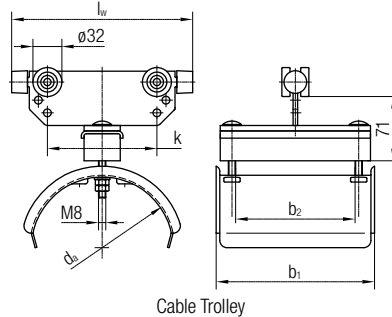

Cable Trolley

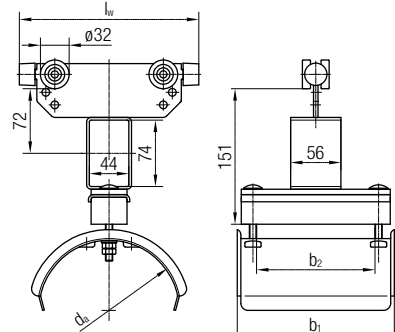

Towing Trolley

Technical details

- Trolley body and cable supports: galvanized steel
- Hardware: galvanized steel
- Standard rollers: ball bearings, galvanized with ZZ-sealing
- Temperature range: -30°C to +80°C
- Stainless steel rollers: ball bearing, V4A with 2RS-sealing
- Temperature range stainless steel: -10°C to +80°C

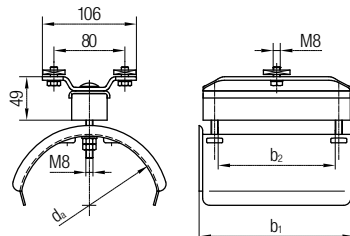

End Clamp

Cable Trolley Order No.	[kg]	Towing Trolley Order No.	[kg]	End Clamp Order No.	[kg]	d _a	l _w	b ₁	b ₂	k	Max. Load Capacity [kg]	Max. Travel Speed [m/min]
024442-160x100	1.30	024452-200x100	2.00	024462-100	1.10	125	160	115	72	81	32	80 (100)
024442-160x160	1.57	024452-200x160	2.37	024462-160	1.35	125	160	175	132	81		
024443-200x160	1.92	024453-200x160	2.72	024463-160	1.60	160	200	175	132	121		
024444-250x100	1.70	024454-250x100	2.20	024464-100	1.30	200	250	115	72	171		
024444-250x160	2.27	024454-250x160	3.07	024464-160	1.85	200	250	175	132	171		
024943-200x160	1.92	024953-200x160	2.72	024963-160	1.60	160	200	175	132	121	16	80

Note

For a better sealing the standard rollers (ZZ) can also be provided with a 2 RS-sealing.
The order-no. has to be completed with the variation designation .../010.

Cable Trolleys for Round Cables Program 0240

Steel Cable Trolleys, Heavy Series
for Clamping of Round Cables with a max. Difference in Diameter of 16 mm

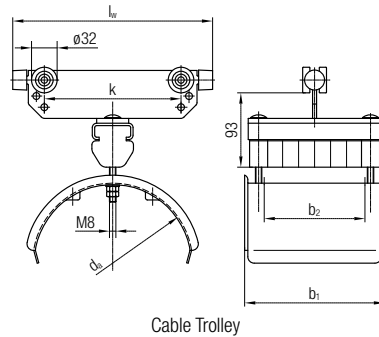

Cable Trolley

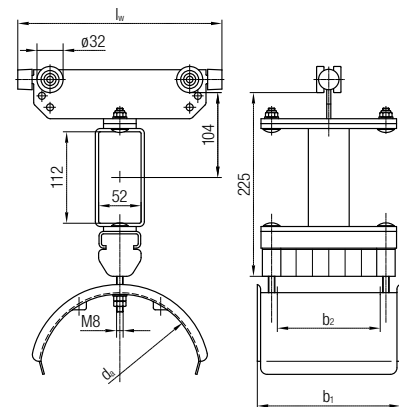

Towing Trolley

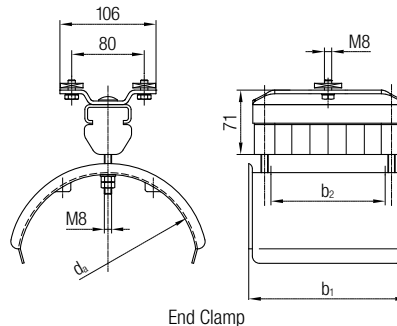

End Clamp

Technical details

- Trolley body and cable supports: galvanized steel
- Hardware: galvanized steel
- Standard rollers: ball bearings, galvanized with ZZ-sealing
- Temperature range: -30°C to +80°C
- Stainless steel rollers: ball bearing, V4A with 2RS-sealing
- Temperature range stainless steel: -10°C to +80°C

Cable Trolley Order No.	[kg]	Towing Trolley Order No.	[kg]	End Clamp Order No.	[kg]	d _a	l _w	b ₁	b ₂	k	Max. Load Capacity [kg]	Max. Travel Speed [m/min]
024474-250x160	2.27	024484-250x160	3.07	024494-160	1.85	200	250	175	125	171	32	80 (100)
024474-250x200	2.67	024484-250x200	3.47	024494-200	2.25	200	250	215	165	171		
024475-320x160	2.72	024485-320x160	3.52	024495-160	2.10	250	320	175	125	241		
024475-320x200	3.12	024485-320x200	3.92	024495-200	2.50	250	320	215	165	241		
024477-400x250	4.52	024487-400x250	5.32	024497-250	3.70	320	400	265	215	321		
024974-250x160	2.27	024984-250x160	3.07	024994-160	1.85	200	250	175	125	171	16	80
024975-320x250	3.62	024985-320x250	4.42	024995-250	3.00	250	320	265	215	241		

Note

For a better sealing the standard rollers (ZZ) can also be provided with a 2 RS-sealing.
The order-no. has to be completed with the variation designation .../010.

Cable Trolleys and Accessories for Traversing, Program 0240

Transfer Guide for C-Rail 024100

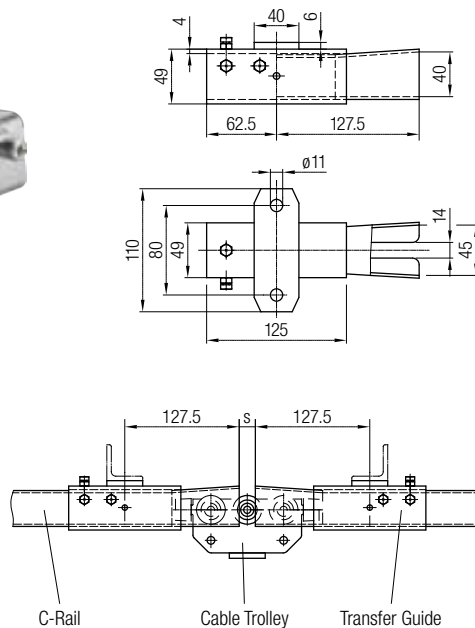

Order No. 024107

- Material: galvanized steel
- Weight: 1.200 kg

Notes

- Two transfer guides must be mounted at the transfer point with the inlet openings against each other
- The distance "s" must not exceed 18 mm
- Vertical deflection max. 2.0 mm
- Horizontal deflection max. 5.0 mm
- All cable trolleys, that pass this transition point must be provided with 3, the towing trolley with 4 pairs of rollers
- Cable trolleys that do not pass this transition point can be used in standard design

Cable Trolleys for Flat Cables with Additional Rollers



Technical details

- Trolley body and cable supports: galvanized steel
- Hardware: galvanized steel
- Standard rollers: ball bearings, galvanized with ZZ-sealing
- Temperature range: -30°C to +80°C

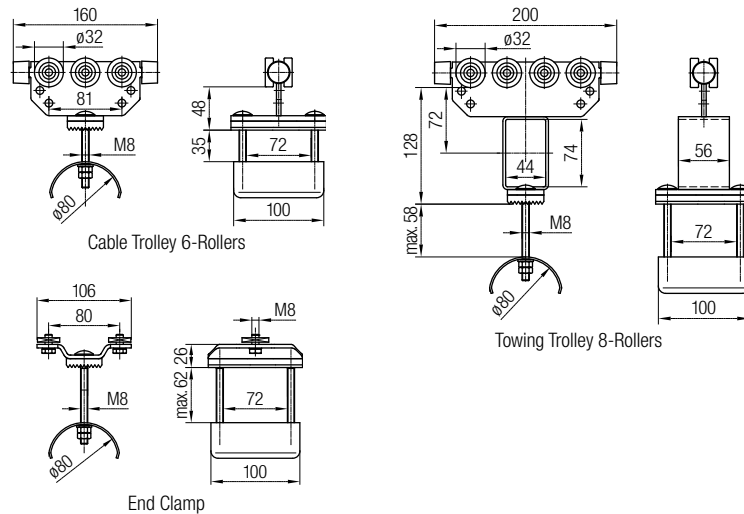

Cable Trolley Order No.	[kg]	Towing Trolley Order No.	[kg]	End Clamp Order No.	[kg]	Max. Load Capacity [kg]	Max. Travel Speed [m/min]
024210-160x100/20	1.03	024220-200x100/020x2	1.85	024230-100x062	0.70	32	63

Cable Trolley for Applications with Increased Horizontal Forces | Program 0240

Cable Trolleys with Horizontal Guide Rollers

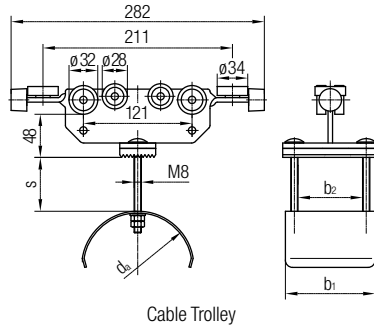

Cable Trolley

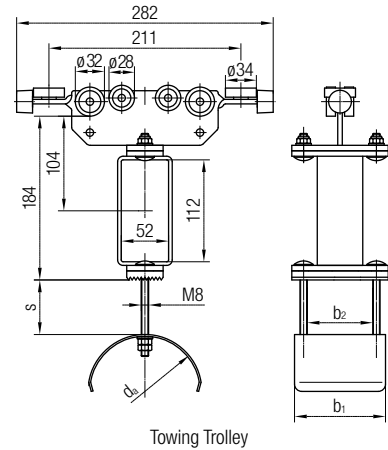

Towing Trolley

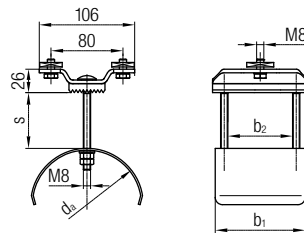

End Clamp

Technical details

- Trolley body and cable supports: galvanized steel
- Hardware: galvanized steel
- Standard rollers: ball bearings, galvanized with ZZ-sealing
- Temperature range: -30°C to +80°C

Cable Trolley Order No.	[kg]	Towing Trolley Order No.	[kg]	End Clamp Order No.	[kg]	d _a [mm]	b ₁ [mm]	b ₂ [mm]	s [mm]	Max. Load Capacity [kg]	Max. Travel Speed [m/min]
024210-200x100/040	1.44	024220-200x100/040	2.21	024230-100x062	0.70	80	100	72	60	32	63
024210-200x160/040	1.68	024220-200x160/040	2.57	024230-160x062	0.94	80	160	132			
024212-200x100/040	1.54	024222-200x100/040	2.31	024232-100x062	0.82	125	100	72			
024212-200x160/040	1.87	024222-200x160/040	2.76	024232-160x062	1.15	125	160	132			

Ideal Control Unit Trolleys Program 0240

Ideal Control Unit Trolleys with Plug and Socket Connection – Basic Configuration

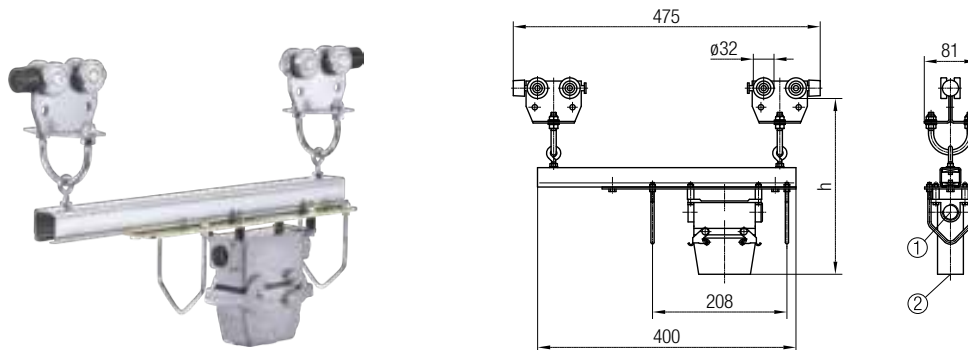

Technical details

- Trolley body and cross bar: galvanized steel
- Hardware: galvanized steel
- Standard rollers: ball bearings, galvanized with ZZ-sealing
- Temperature range: -30°C to +80°C

Note

Ideal control unit trolley with basic configuration without end clamp and without cable glands

Order No.	Number of Poles	Connecting Threads		h [mm]	possible Attachment Parts	Weight [kg]	Max. Load Capacity [kg]	Max. Travel Speed [m/min]
		①	②					
024776-16	16+PE	M25x1.5	M25x1.5	275	end clamp 023269 and 023299 brake glider 024784 and brake trolley 024785	3.04	40	63
024776-24	24+PE	M25x1.5	M32x1.5	290		3.34		

Ideal Control Unit Trolleys with Plug and Socket Connection – Pre-Assembled

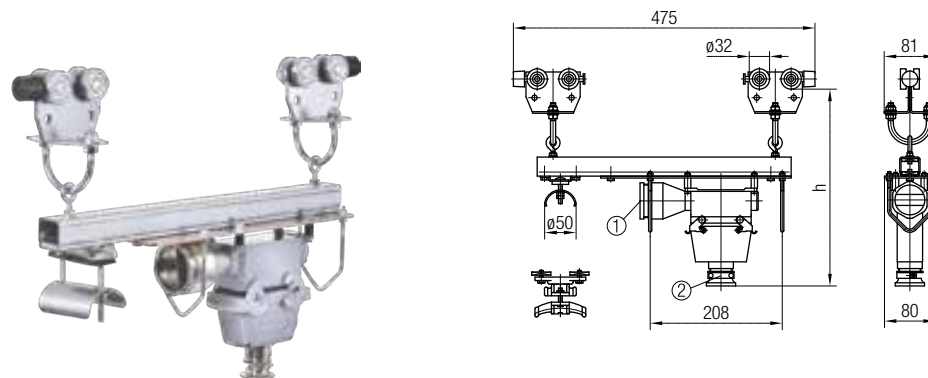

Technical details

- Trolley body and cross bar: galvanized steel
- Hardware: galvanized steel
- Standard rollers: ball bearings, galvanized with ZZ-sealing
- Temperature range: -30°C to +80°C

Note

Ideal control unit trolley pre-assembled with end clamp and with cable glands

Order No.	Number of Poles	Cable Glands		h [mm]	Type for	possible Attachment Parts	Weight [kg]	Max. Load Capacity [kg]	Max. Travel Speed [m/min]
		①	②						
024778-16	16+PE	25x42	25x21	310	flat cables	brake glider 024784 brake trolley 024785	3.61	40	63
024778-24	24+PE	25x42	32x29	325			3.99		
024779-16	16+PE	25x29	25x21	310	round cables		3.40		
024779-24	24+PE	25x29	32x29	325			3.78		

Ideal Control Unit Trolleys Program 0240

Ideal Control Unit Trolley with Plastic Terminal Box – Basic Configuration

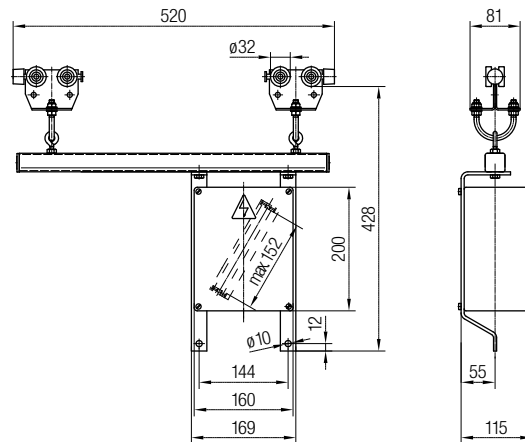

Technical details

- Trolley body and cross bar: galvanized steel
- Hardware: galvanized steel
- Standard rollers: ball bearings, galvanized with ZZ-sealing
- Temperature range: -30°C to +80°C

Note

Ideal control unit trolley with basic configuration without end clamp, cable glands and terminals

Order No.	possible Attachment Parts	Weight [kg]	Max. Load Capacity [kg]	Max. Travel Speed [m/min]
024780	end clamp 023269, 023299; brake glider 024784; brake trolley 024785	4.3	40	63

Ideal Control Unit Trolleys with Plastic Terminal Box – Pre-Assembled

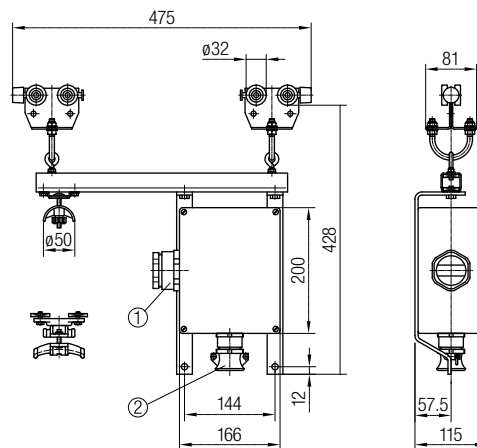
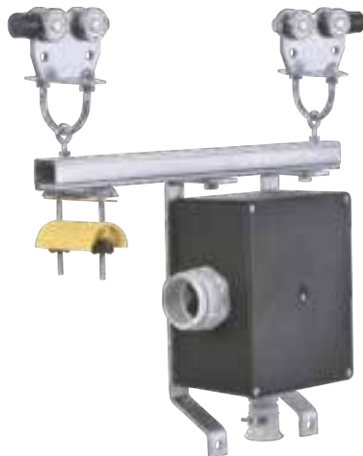

Technical details

- Trolley body and cross bar: galvanized steel
- Hardware: galvanized steel
- Standard rollers: ball bearings, galvanized with ZZ-sealing
- Temperature range: -30°C to +80°C

Note

Ideal control unit trolley pre-assembled with end clamp, cable glands and terminals

Order No.	Number of Poles	Cable Glands		Type for	possible Attachment Parts	Weight [kg]	Max. Load Capacity [kg]	Max. Travel Speed [m/min]
		①	②					
024774-16	16 + PE	50x42	25x21	flat cables	brake glider 024784	5.35	40	63
024774-24	24 + PE	50x42	32x29			5.75		
024775-16	16 + PE	32x29	25x21	round cables	brake trolley 024785	5.30	40	63
024775-24	24 + PE	32x29	32x29			5.61		

Ideal Control Unit Trolleys Program 0240

Ideal Control Unit Trolleys with Terminal Box of Steel – Basic Configuration

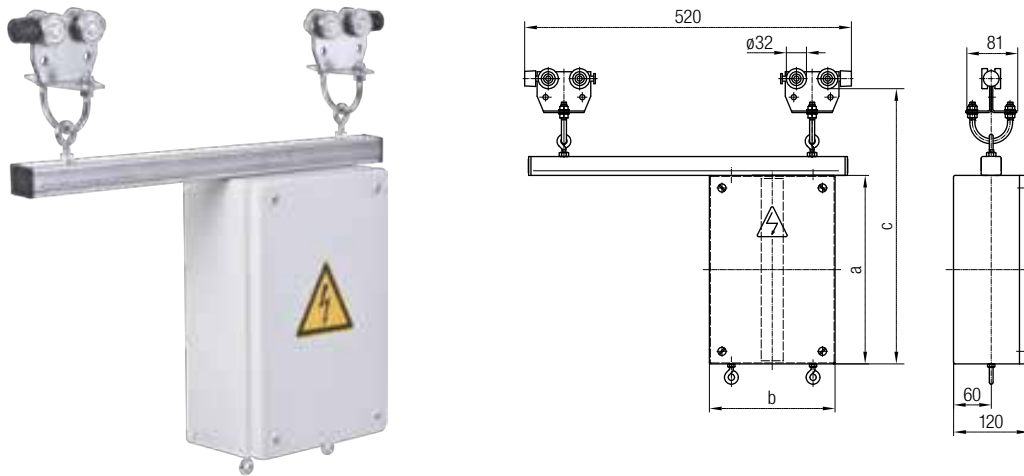

Technical details

- Trolley body and cross bar: galvanized steel
- Hardware: galvanized steel
- Standard rollers: ball bearings, galvanized with ZZ-sealing
- Temperature range: -30°C to +80°C
- Stainless steel rollers: ball bearings V4A with 2RS-sealing
- Temperature range stainless steel: -10°C to +80°C

Note

Ideal control unit trolley with basic configuration without end clamp, cable glands and terminals

Order No.	a [mm]	b [mm]	c [mm]	possible Attachment Parts	Weight [kg]	Max. Load Capacity [kg]	Max. Travel Speed [m/min]
024781-200x200	200	200	338	end clamp 023269, 023299 brake glider 023184; brake trolley 023185	5.30	40	63
024781-300x200	300		438		6.30		
024791-200x200	200	200	338	end clamp 023469, 023499	5.30	20	63
024791-300x200	300		438		6.30		

Control Trolley Upper Parts

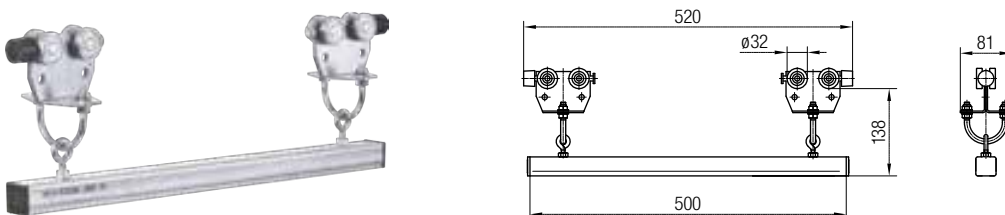

Technical details

- Trolley body and cross bar: galvanized steel
- Hardware: galvanized steel
- Standard rollers: ball bearings, galvanized with ZZ-sealing
- Temperature range: -30°C to +80°C
- Stainless steel rollers: ball bearings V4A with 2RS-sealing
- Temperature range stainless steel: -10°C to +80°C

Note

For a better sealing the standard rollers (ZZ) can also be provided with a 2RS-sealing. The order-no. has to be completed with the variation designation ... / 010.

Order No.	Weight [kg]
024771	1.95
024771/500	1.95

Ideal Control Unit Trolleys Program 0240

Basic Ideal Control Unit Trolleys for Round Cables

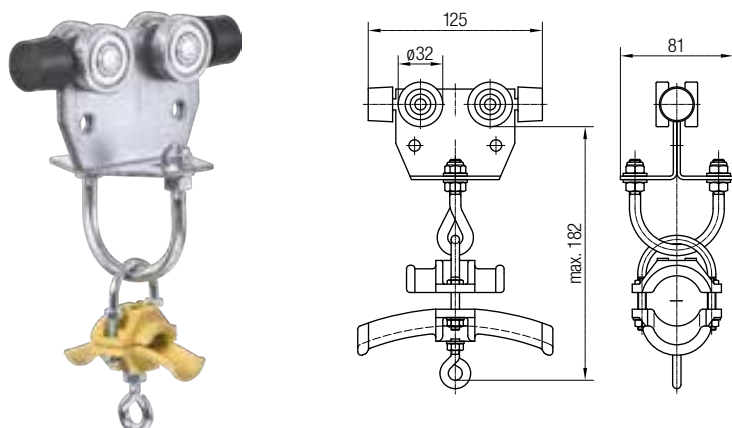

Technical details

- Trolley body and bracket: galvanized steel
- Hardware: galvanized steel
- Standard rollers: ball bearings, galvanized with ZZ-sealing
- Cable clips: plastic
- Temperature range: -30°C to +80°C

Order No.	for Cable- \varnothing [mm]	Weight [kg]
024711-16	10 ... 16	0.640
024711-25	17 ... 25	0.660
024711-36	26 ... 36	0.720

Note

These control trolleys are used if the round cable is installed directly and without an additional terminal box up to the control station.

Accessories for Festoon Systems Program 0240

Application Examples

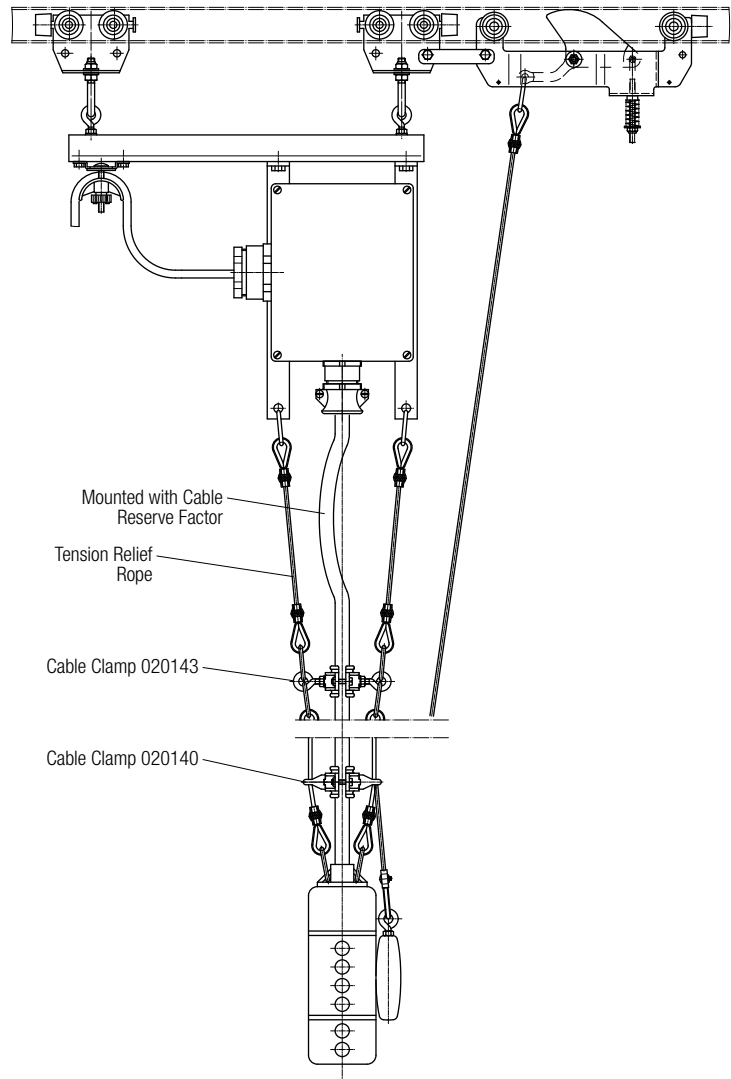
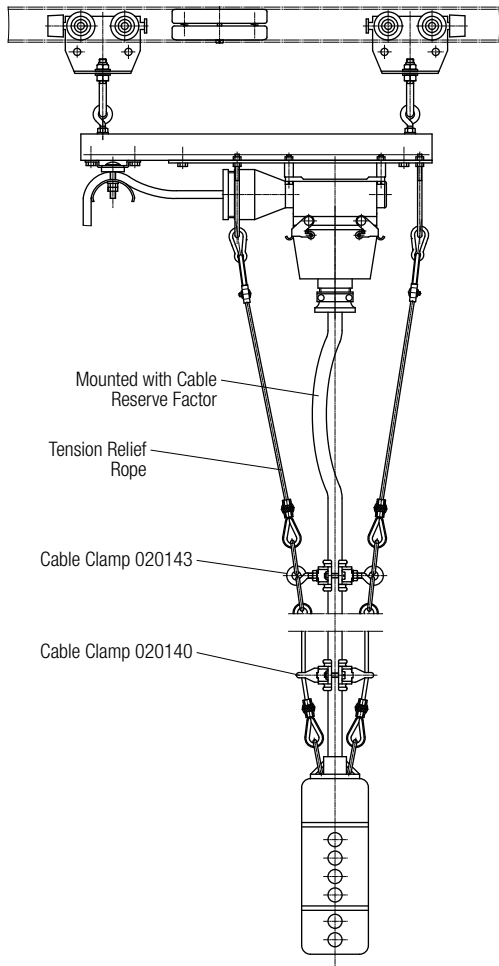
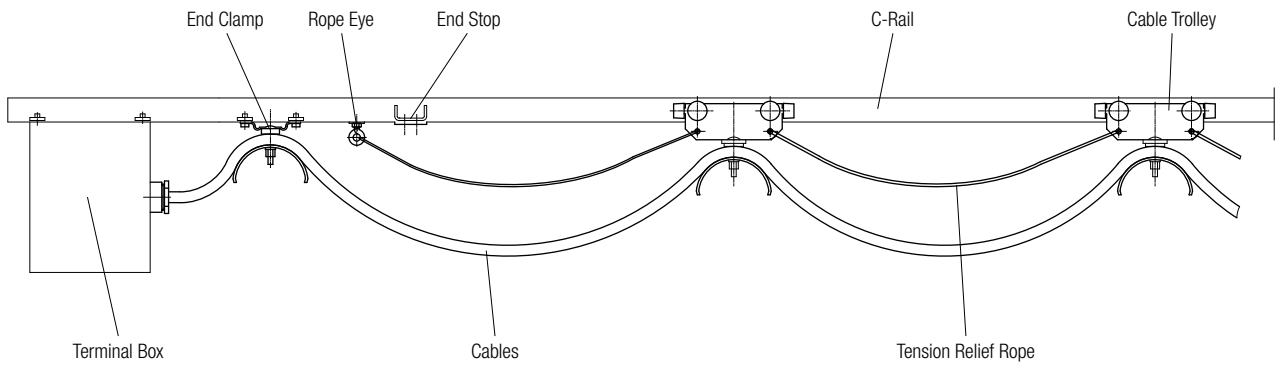

Note

Special pendant station round cables with extruded steel ropes, that do not require separate tension relief devices, are listed in our cable catalog KAT0130-0002.

Accessories for Festoon Systems Program 0240

Towing Ropes Pre-Assembled

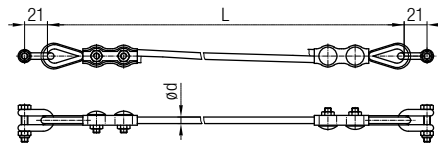

Type A (Shackle)

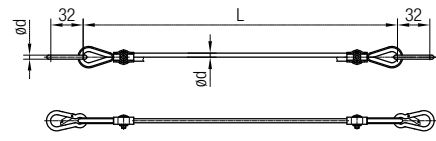

Type B (with spring safety hook)

Order No.	ø d [mm]	Type	Material	Weight [kg/m]
020318-06	6.0	A	plastic	0.14
020329-04	4.0		steel. PVC-covered	0.16
020329-02,5	2.5	B		0.14
020318-06/500	6.0	A	acid-resistant plastic	0.14

Ropes

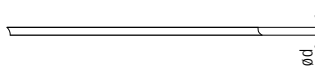

Order No.	ø d [mm]	Material	Weight [kg/m]
020302-6	6.0	plastic	0.020
020305-02,5	2.5	steel. PVC-covered	0.009
020301-6	6.0	acid-resistant plastic	0.020
020304-02	2.0	stainless steel V4A	0.015

Shackles

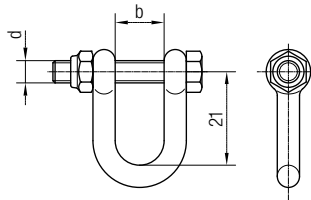

Order No.	d	b [mm]	Package Size [pc.]	Material	Weight [kg]
020211-6P	M6	8	20	galvanized steel	0.400
020211-5P/501	M5	11	20	stainless steel V4A	0.300

Spring Safety Hook

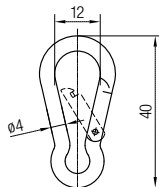

Order No.	Material	Weight [kg]
020215-40x4	galvanized steel	0.010
020415-40x4	stainless steel V4A	0.010

Rope Thimbles

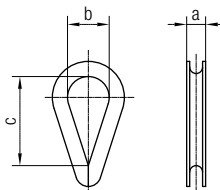

Order No.	a [mm]	b [mm]	c [mm]	Material	Weight [kg]
020120-3	5.0	11	23.5	galvanized steel	0.008
020120-4	6.5	13	28.5		0.010
020450-3	5.0	11	23.5	stainless steel V4A	0.008
020450-4	6.5	13	28.5		0.010

Accessories for Festoon Systems Program 0240

Rope Clip

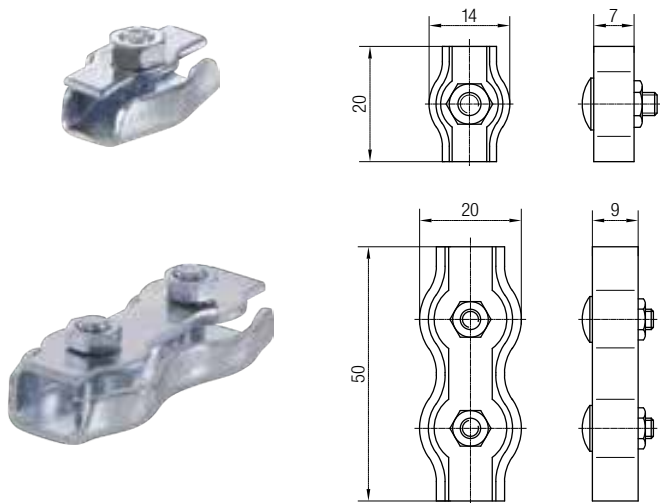

Simplex Rope Clip Order No.	Material	Weight [kg]
020122-3	galvanized steel	0.010
020452-3	stainless steel V4A	0.010

Duplex Rope Clip Order No.	Material	Weight [kg]
020123-5	galvanized steel	0.030
020453-5	stainless steel V4A	0.030

Rope Eyes

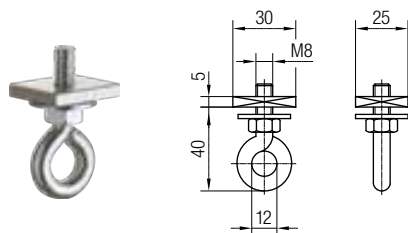

Order No.	Material	Weight [kg]
020218-08	galvanized steel	0.07
020458-08	stainless steel V4A	0.07

Cable Clamps

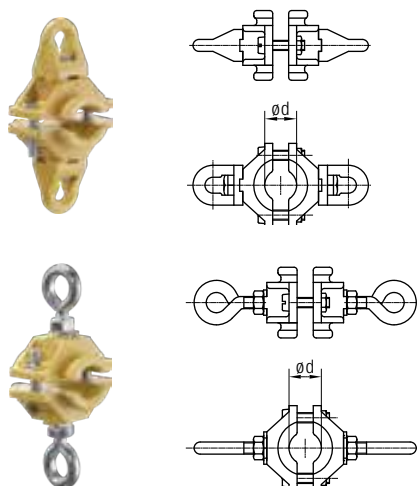

Cable Clamp Order No.	ø d [mm]	Material	Weight [kg]
020140-16	11 ... 16	plastic, hardware: galvanized steel	0.05
020140-25	17 ... 25		0.08
020140-36	26 ... 36		0.13

Cable Clamp Order No.	ø d [mm]	Material	Weight [kg]
020143-16	10 ... 16	plastic, hardware: galvanized steel	0.06
020143-25	17 ... 25		0.08
020143-36	26 ... 36		0.14

Accessories for Festoon Systems Program 0240

Brake Glider

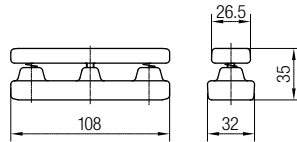

Order No. 024784

- Basic material: plastic
- Hardware: galvanized steel
- Weight: 0.100 kg

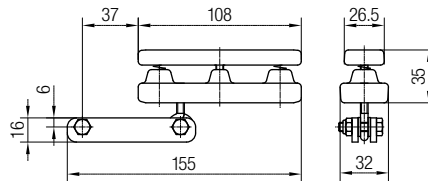

Brake Glider and hardware Order No. 024719

- Basic material: plastic
- Hardware: galvanized steel
- Weight: 0.200 kg

Brake Trolley

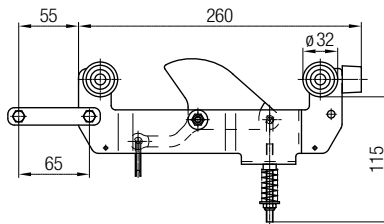
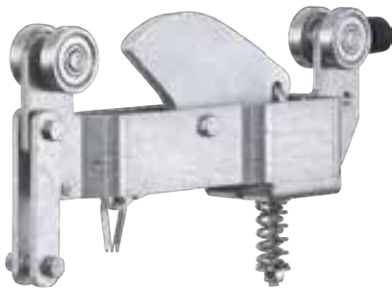

Order No. 024785

- Material: galvanized steel
- Hardware: galvanized steel
- Brake hammer: cast iron
- Weight: 1.200 kg

Accessories for Festoon Systems Program 0240

Cable Trolley Upper Parts

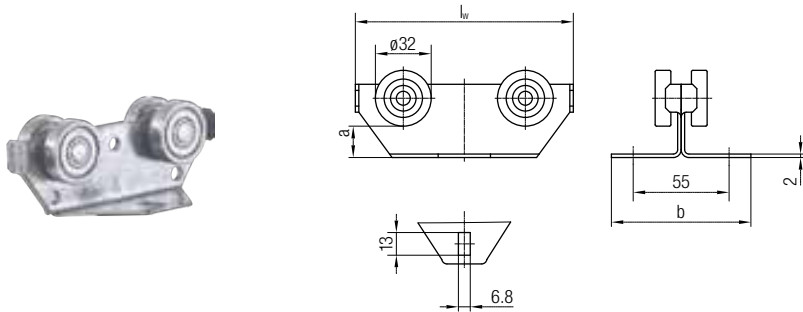

Cable Trolley Upper Parts without Buffer Order No.	l_w [mm]	b [mm]	a [mm]	Material	Max. Load Capacity [kg]	Weight [kg]
024512-80	80	74	13.0	galvanized steel	25	0.31
024512	125	80	18.0			0.40

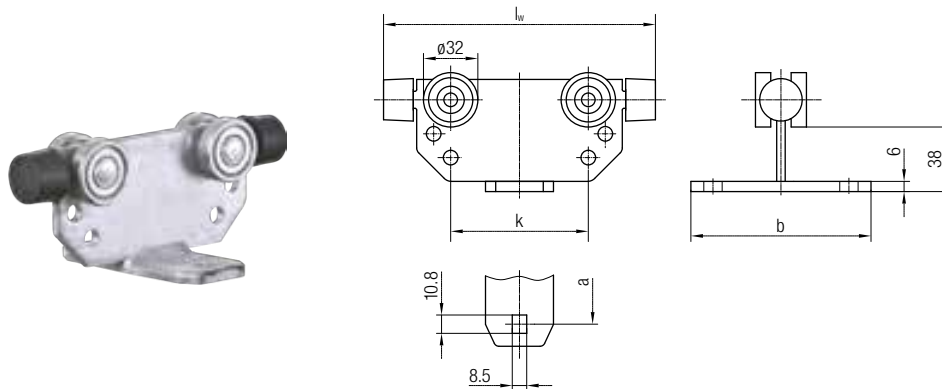

Cable Trolley Upper Parts with Buffer Order No.	l_w [mm]	b [mm]	a [mm]	Material	k [mm]	Max. Load Capacity [kg]	Weight [kg]
024510-125x100	125	106	80	galvanized steel	46	32	0.55
024510-125x160	125	166	140		46		0.67
024510-160x100	160	106	80		81		0.63
024510-160x160	160	166	140		81		0.75
024510-200x100	200	106	80		121		0.73
024510-200x160	200	166	140		121		0.85

Accessories for Festoon Systems Program 0240

Plastic Trolleys 2 Rollers

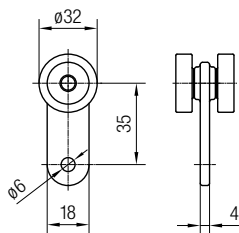

Order No. 024331

- Type of roller: plastic roller with friction bearing
- Max. load capacity: 4 kg
- Max. travel speed: 20 m/min
- Weight: 0.020 kg

Plastic Trolleys 4 Rollers

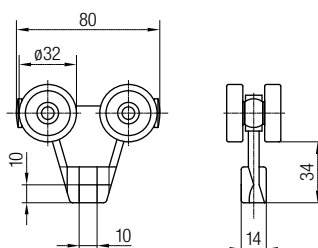

Order No. 024504

- Ball bearing: plastic roller with friction bearing
- Max. load capacity: 10 kg
- Max. travel speed: 20 m/min
- Weight: 0.050 kg

Steel Trolley 2 Rollers

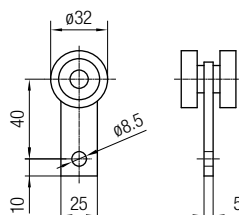

Order No. 024330

- Ball bearing: galvanized steel
- Max. load capacity: 12.5 kg
- Max. travel speed: 40 m/min
- Weight: 0.150 kg

Steel Trolley 4 Rollers without Buffer

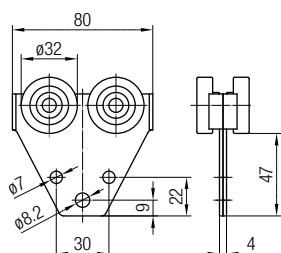

Order No. 024323

- Ball bearing: galvanized steel
- Max. load capacity: 32 kg
- Max. travel speed: 50 m/min
- Weight: 0.320 kg

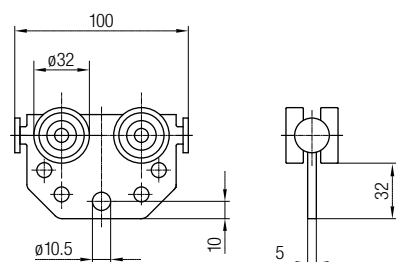

Order No. 024340-100

- Ball bearing: galvanized steel
- Max. load capacity: 32 kg
- Max. travel speed: 50 m/min
- Weight: 0.380 kg

Accessories for Festoon Systems Program 0240

Steel Trolley 4 Rollers with Buffer

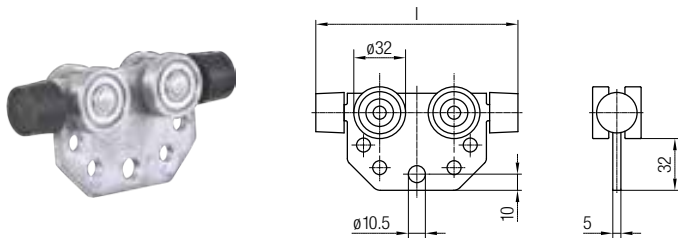

Order No.	Type of Roller	Max. Load Capacity [kg]	Max. Travel Speed [m/min]	Weight [kg]
024340-125	ball bearings: galvanized steel	32	63	0.40
024340-160				0.50
024340-200				0.60

S-Hook

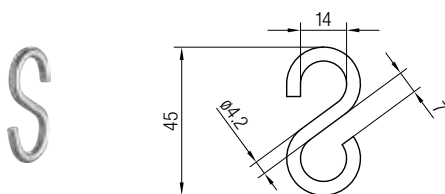

- Order No. 020118-45x4**
- Material: galvanized steel
 - Weight: 0.016 kg

Spring Safety Hook

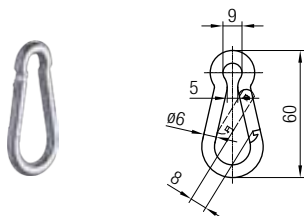

- Order No. 020215-60x6**
- Material: galvanized steel
 - Weight: 0.030 kg

Cable Collar, Plastic

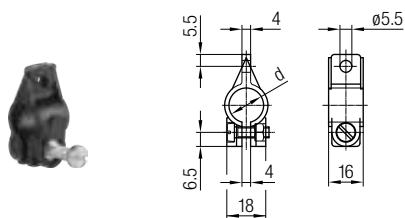

Order No.	Cable- ϕ d [mm]	Material	Weight [kg]
020111-08	8	plastic, hardware: galvanized steel	0.0070
020111-10	10		0.0077
020111-11	11		0.0077
020111-12.5	12.5		0.0081
020111-14	14		0.0084
020111-16	16		0.0085
020111-18	18		0.0850
020111-20	20		0.0100
020111-22	22		0.0100
020111-25	25		0.0110
020111-28	28		0.0120
020111-32	32		0.0130
020111-36	36	0.0140	

Note
For attachment to the trolley with S-hook.

Accessories for Festoon Systems Program 0240

Strap for Cable Bundle

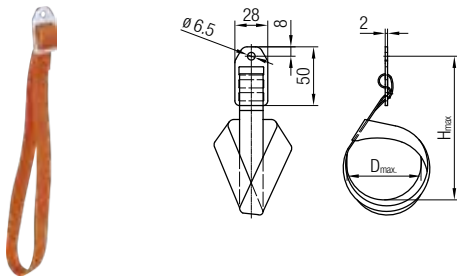

Order No.	D _{max.} [mm]	H _{max.} [mm]	Material	Weight [kg]
020117-080	80	150	plastic, hardware: galvanized steel	0.020
020117-160	160	230		0.030

Note

For attachment to the trolley with S-hook.

Cable Clips with Bracket

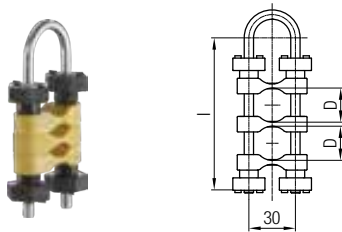

Order No.	Number of Loops n _D	Max. Cable-ø per Loop D [mm]	Total of all Cable-ø max. [mm]	l [mm]	Weight [kg]
020137-1X18	1	8-18	18	63	0.055
020137-1X22	1	8-22	22	80	0.060
020137-2X32	2	8-22	32	80	0.065
020137-2X44	2	8-22	44	100	0.070
020137-3X30	3	8-22	30	80	0.070
020137-3X66	3	8-22	66	125	0.090
020137-4X72	4	8-22	72	125	0.090
020137-5X70	5	8-22	70	125	0.095

Note

To be used in combination with trolley 024504.

Helpful Hints

Determination of the Load Capacity of C-Rails

Technical details / bases of calculation

The permissible load of the C-rails can be determined with the help of the diagrams.
The following bases of calculation have been considered::

1. Beam on 2 supports, loaded by distributed load symmetrical to the beam center
2. $\sigma_{\text{zul}} = 100 \text{ N/mm}^2$ without consideration of the lower flange stress
3. $\sigma_V \leq 160 \text{ N/mm}^2$, reference stress from bending stress and lower flange stress
4. $f = l_A/250$ allowed deflection from load and self-weight of the C-rail
5. The loading is considered symmetrically distributed over all the track supports (brackets)

Calculation example

Given:

F_{LW} = Load/trolley	18 kg
l_w = Length of cable trolley	125 mm
Z = Number of cable trolleys	10
l_b = Storage length	1.25 m
$(m) = Z \times l_w / 1000$	

Load Diagram for C-Rail 40 x 40 x 2.5 (024100 / 024104 / 024109)

required load capacity of the track support brackets [kg]

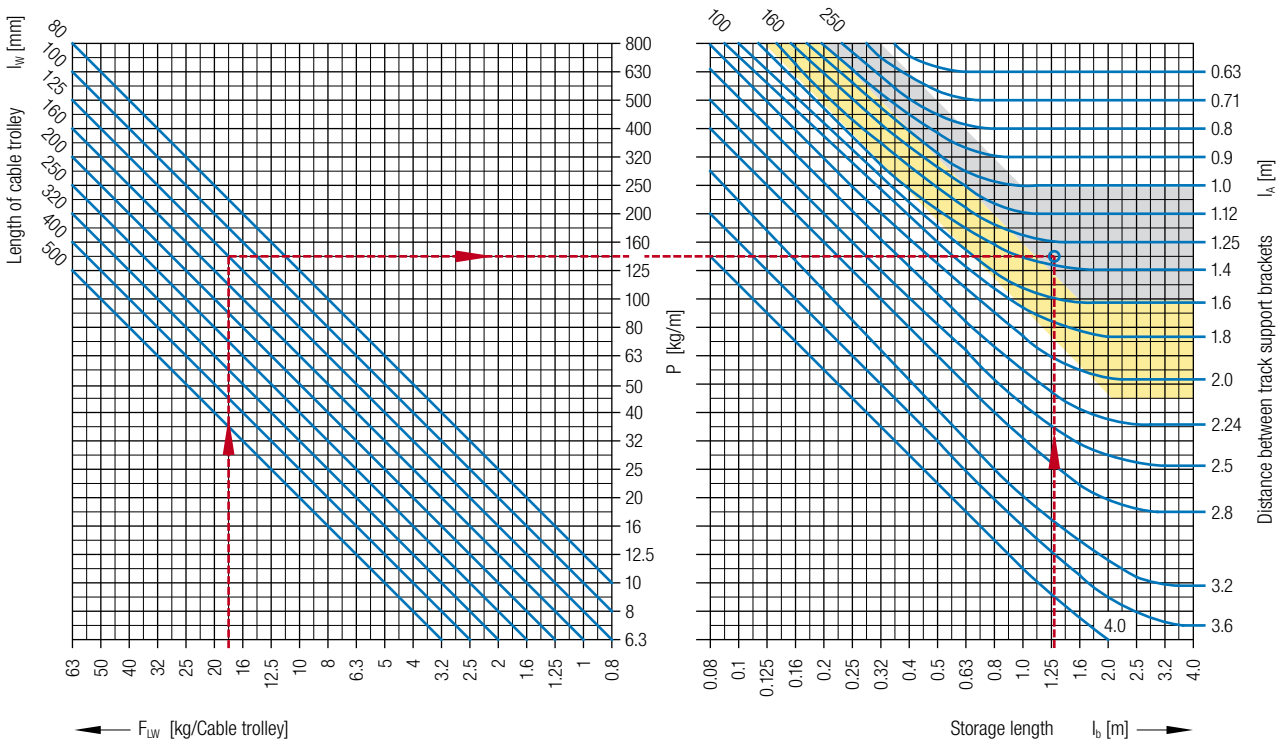

Solution for C-rail 40 x 40 x 2.5

From diagram

- Required distance between the track support brackets [l_k] = 1.30 m
- Required load capacity of the track support brackets = 250 kg

Helpful Hints

Load Diagram for CI-Rail Reinforced (024052-6)

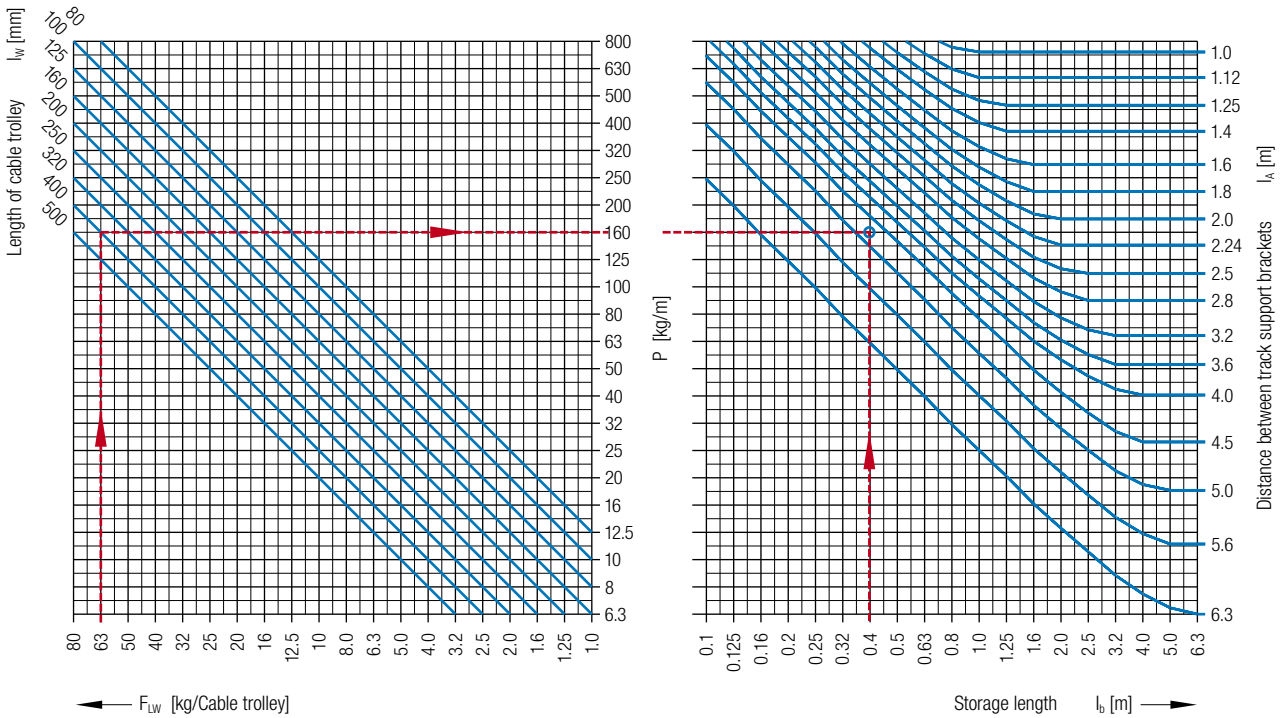

Targets:
 Load per trolley [F_{LW}] = 63 kg; Length of cable trolley [l_w] = 400 mm
 Number of cable trolleys [Z] = 1; Storage length [l_b] = 0.400 m; (m) = $Z \times l_w / 1000$

From diagram:
 Required distance between track support brackets [l_a] = 4.80 m

Load Diagram for CV-Rail Reinforced (024030-6)

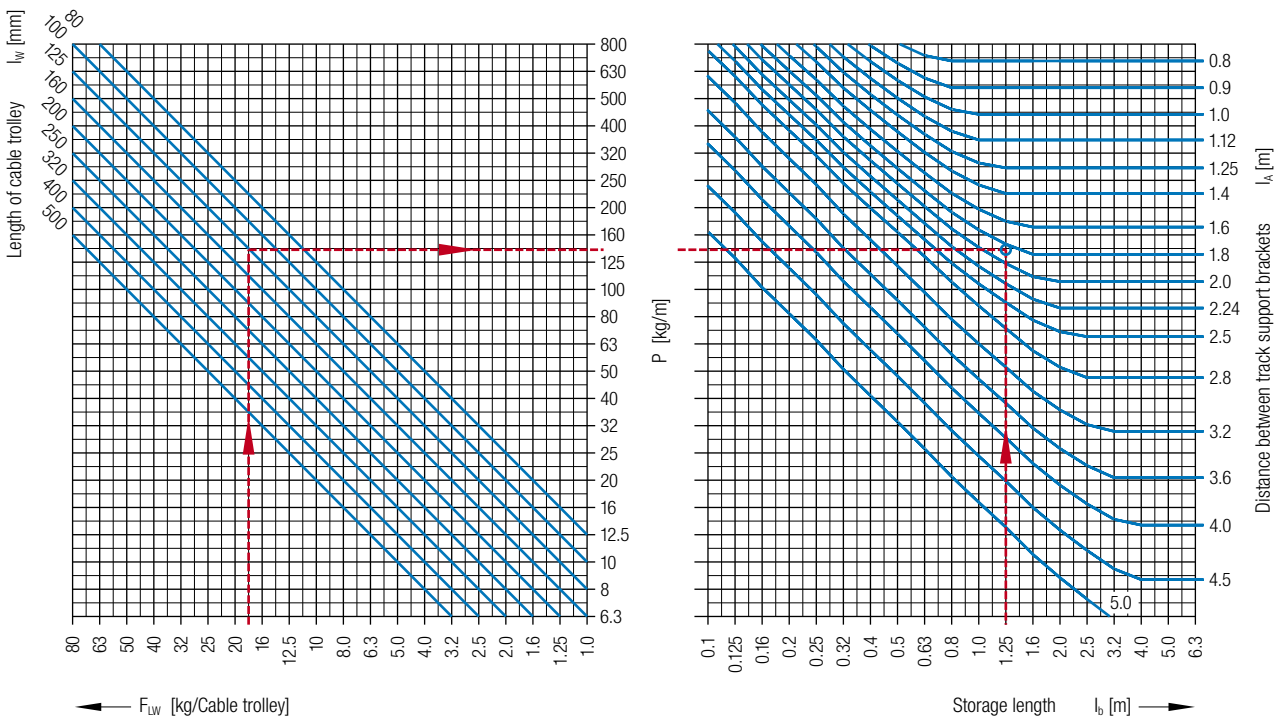

Targets:
 Load per trolley [F_{LW}] = 18 kg; Length of cable trolley [l_w] = 125 mm
 Number of cable trolleys [Z] = 10; Storage length [l_b] = 1.25 m; (m) = $Z \times l_w / 1000$

From diagram:
 Required distance between track support brackets [l_a] = 1.85 m

Helpful Hints

Technical Data

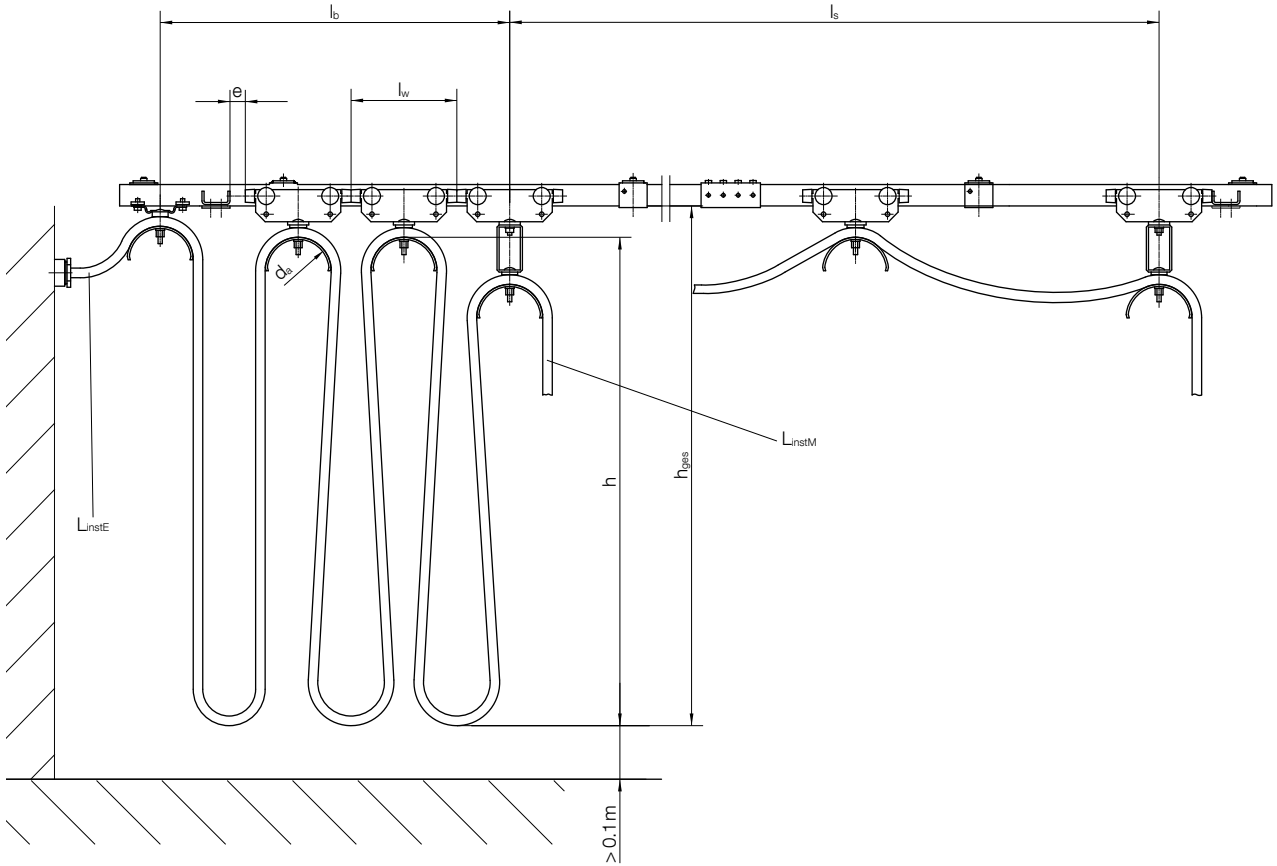

Formulas to Determine the Number of Loops, Cable Length and Loop Depth

Number of loops:

$$n = \frac{f(l_s + e)}{2 \cdot h + 1.25 \cdot d_a - f \cdot l_w}$$

Storage length:

$$l_b \approx n \cdot l_w + e \quad [m]$$

System cable length:

$$L_{Syst} = f(l_s + l_b) \quad [m]$$

Total cable length:

$$L_{Best} = L_{Syst} + L_{instE} + L_{instM} \quad [m]$$

Loop length:

$$L_{Schl} = \frac{L_{Syst}}{n} \quad [m]$$

Loop depth:

$$h = \frac{L_{Schl}}{2} - 0.63 \cdot d_a \quad [m]$$

- d_a [m] = cable support diameter
- e [m] = free space in storage area
(recommendation ≥ 0.1 m)
- f = recommended cable factor (see table)
- h [m] = loop depth
(measured from top edge of cable support)
- h_{ges} [m] = loop depth
(measured from lower edge of cable support)
- l_b [m] = storage length incl. free space
- l_s [m] = travel distance
- l_w [m] = cable trolley length
- L_{Best} [m] = total cable length
- L_{instE} [m] = installation length, end clamp side
- L_{instM} [m] = installation length, towing side
- L_{Schl} [m] = cable length per loop
- L_{Syst} [m] = required cable length
(measured from mid of end clamp to mid of towing trolley or towing clamp)
- n = number of loops

Helpful Hints

Definition of the Cable Arrangement and Cable Trolley Selection

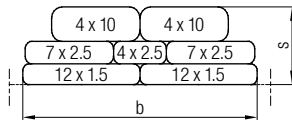

Example for flat cable trolleys

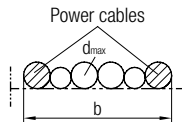

Example for round cable trolleys

1. Formula for calculating the approximate load per trolley F_{LW}

$$F_{LW} \approx 2 \cdot h \cdot G_L \text{ [kg]}$$

G_L [kg/m] = weight of the cable package

2. Selection of the cable trolley type
3. Required cable support diameter based upon minimum bending radius of the cables
4. Select cable support width b_2 to accommodate the cable package width
5. Determine length of trolley l_w

For round cables:

$$l_w \geq d_a + 2 \cdot d_{max} + 10 \text{ [mm]}$$

For flat cables:

$$l_w \geq d_a + 2 \cdot s + 10 \text{ [mm]}$$

Cable Factors

Travel Speed v [m/min]	Cable Factor f at h [m]				
	< 0.8	0.8 - 1.2	1.3 - 2	2.1 - 3.2	3.3 - 5
< 32	1.10	1.10	1.10	1.10	1.10
32 - 40	1.15	1.10	1.10	1.10	1.10
41 - 50	1.20	1.15	1.10	1.10	1.10
51 - 63	1.25	1.20	1.15	1.10	1.10
64 - 80	-	1.25	1.20	1.15	1.10
81 - 100	-	-	1.25	1.20	1.15
101 - 120	-	-	-	1.25	1.20

Depending on the operating conditions the cables must be installed with an additional cable length. The additional length is calculated by taking into account the cable factor f . We recommend to select the cable factor according to above table.

For values outside the gray area, please contact us directly. Special precautions might be required in those cases under extreme operating conditions, such as the installation of shock cords.

Permissible Loads of the Rollers

Travel Speed V [m/min]	Average running time per day [h]				
	< 4	4 - 8	8 - 16	-	-
< 16	< 2	2 - 4	< 2	2 - 4	4 - 8
16 - 32	-	-	-	< 2	2 - 4
32 - 63	-	-	-	-	< 2
63 - 80	-	-	-	-	< 2
80 - 100	-	-	-	-	< 2

Type of Roller [ø 32 mm]	Permissible Load of the Rollers [kg]				
	50	40	32	25.0	20
Ball Bearing, galvanized	25	20	16	12.5	10
Ball Bearing V4A	25	20	16	12.5	10
Ball Bearing with PUR Bandage	25	20	16	12.5	10

The lifetime of the rollers depends on the load (Hertzian stress) and the frequency of operation.

The proper selection, based on travel speed, average running time per day (based on one year) and permissible load of the trolleys with various roller types, can be made by using the above table.

Your Applications - our Solutions!

Festoon systems by Conductix-Wampfler represent only one of the many solutions made possible by the broad spectrum of Conductix-Wampfler components for the transport of energy, data and fluid media. The solutions we deliver for your applications are based on your specific requirements. In many cases, a combination of several different Conductix-Wampfler systems can prove advantageous. You can count on all of Conductix-Wampfler's Business Units for hands-on engineering support - coupled with the perfect solution to meet your energy management and control needs.



Cable reels

Motorized reels and spring reels by Conductix-Wampfler hold their own wherever energy, data and media have to cover the most diverse distances within a short amount of time - in all directions, fast and safe.



Festoon systems

It's hard to imagine Conductix-Wampfler cable trolleys not being used in virtually every industrial application. They're reliable and robust and available in an enormous variety of dimensions and designs.

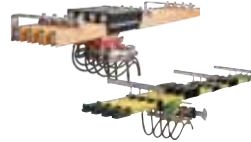

Conductor rails

Whether they're enclosed conductor rails or expandable single-pole systems, the proven conductor rails by Conductix-Wampfler reliably move people and material.



Non-insulated conductor rails

Extremely robust, non-insulated conductor rails with copper heads or stainless steel surfaces provide the ideal basis for rough applications, for example in steel mills or shipyards.



Energy guiding chains

The "Jack of all trades" when it comes to transferring energy, data, air and fluid hoses. With their wide range, these energy guiding chains are the ideal solution for many industrial applications.



Slip ring assemblies

Whenever things are really "moving in circles", the proven slip ring assemblies by Conductix-Wampfler ensure the flawless transfer of energy and data. Here, everything revolves around flexibility and reliability!



Inductive Power Transfer IPT®

The no-contact system for transferring energy and data. For all tasks that depend on high speeds and absolute resistance to wear.



Reels, retractors and balancers

Whether for hoses or cables, as classical reels or high-precision positioning aids for tools, our range of reels and spring balancers take the load off your shoulders.



Jib boom

Complete with tool transporters, reels, or an entire media supply system - here, safety and flexibility are key to the completion of difficult tasks.



Conveyor systems

Whether manual, semiautomatic or with Power & Free – flexibility is achieved with full customization concerning layout and location.

www.conductix.com

Conductix-Wampfler GmbH

Rheinstrasse 27+33
79576 Weil am Rhein
Germany

Hotline

Phone +49 (0) 7621 662-222

Phone +49 (0) 7621 662-0

Fax +49 (0) 7621 662-144

info.de@conductix.com

www.conductix.com

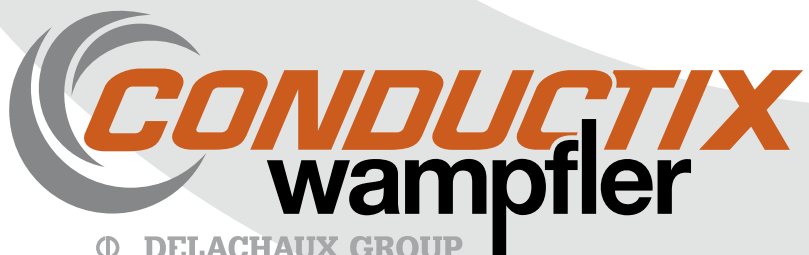

Ⓞ DELACHAUX GROUP